

INSTALLATION, USE AND MAINTENANCE MANUAL

PLI

Inverter air-water Chillers and heat pumps with low-GWP refrigerant
35 - 50 kW



R-454B
Low GWP

A2L gas leak
detection

Plate
exchanger

Axial fan

Cooling only

Heating/
Cooling

Packaged
execution

PLUS

- » Refrigerant with GWP of less than 500
- » High seasonal efficiency values
- » Electronic expansion valve
- » Inverter scroll configuration single circuit
- » Remote connectivity with the most common protocols
- » Possibility to configure low-noise versions
- » Gas leak detection systems for standard



Dear Customer,

Thank you for placing your trust in one of the products of Galletti S.p.a

This product is the result of our work and our commitment to design, research, and production and has been made from the finest materials, employing state-of-the-art components and production technology.

The CE marking of the product ensures its compliance with the safety requirements of the following directives: the Machinery Directive, the Electromagnetic Compatibility Directive, the Electrical Safety Directive, and the Pressure Equipment Directive. Fulfillment of the Ecodesign requirements is fully in keeping with the environmental awareness that has always guided our company.

The company certification of the Quality and Safety management system ensures that product quality is constantly checked and improved, and that the product is manufactured in full compliance with the highest standards.

By choosing our product, you have opted for Quality, Reliability, Safety, and Sustainability.

At your disposal, once again.

Galletti S.p.a

ORIGINAL INSTRUCTIONS

The water chillers and heat pumps comply with directive 2014/68/EC (PED).

The technical and dimensional data reported in this manual may be modified in view of any product improvement.

For any information , please contact the company: info@galletti.it

The unit data are reported on the rating label in this page. (FAC-SIMILE)

THE LABEL SHOWS THE FOLLOWING DATA:

- Series and size of the unit
- Date of manufacture
- Main technical data
- Manufacturer
- The label is applied on the unit, usually on the enclosing panels

IMPORTANT: NEVER REMOVE THE LABEL

- Unit serial number
- The serial number permits to identify the technical characteristics and the components installed
- Without this datum it will be impossible to identify the unit correctly

	<p>Galletti S.p.A. - Via L.Romagnoli 12/a 40010 Bentivoglio (BO) Italy</p> <p>Made in Italy CATEGORY category</p>
<p>Serial number Code Date of production Cooling capacity (W) Heating capacity (W) Power supply Power input (kW) Weight (kg) Max power input (kW) Max running amperage (A) HP power input (kW) Refrigerant Max refrigerant pressure Max refrigerant temperature (°C)</p>	

GENERAL CAUTIONARY NOTES

- Do not put into service until you have read and understood the information in the following manual. This document, together with all other documents provided, should be retained for the entire life of the unit. Contact the manufacturer for any further information.
- Keep this manual intact in a safe place for the all life of the unit.
- Carefully read all the information contained in this manual, paying special attention to sections marked "Important" and "Warning"; failure to comply with the instructions provided could result in injury to persons or damage to the equipment.
- Should a fault occur, consult this manual and if necessary contact the nearest Galletti S.p.A. service centre.
- All installation and maintenance operations must be carried out by qualified personnel, unless otherwise indicated in this manual.
- The first start up must be carried out exclusively by qualified personnel and authorized by Galletti S.p.A. (see warranty sheet attached).
- Before performing any work on the unit, disconnect it from the power supply.
- Failure to comply with the rules provided in this manual will result in the immediate invalidation of the warranty.
- Galletti S.p.A. shall not accept any liability for injury or damage resulting from improper use of the equipment or failure to comply with the directions provided in this manual and on the unit it self.
- It's mandatory to install filters heat exchangers protection will immediately invalidate the warranty.

SAFETY SYMBOLS



Carefully read this manual.



Warning



Use personal protective equipment (gloves for refrigerant, protective goggles)



Warning: the unit of this range are charged with A2L fluid (slightly flammable) R454B



Warning:

Electrical and electronic products may not be mixed with unsorted household waste. Do NOT try to dismantle the system yourself: the dismantling of the system, treatment of the refrigerant, of oil and of other parts must be done by an authorized installer and must comply with applicable legislation. Units must be treated at a specialized treatment facility for reuse, recycling and recovery. By ensuring this product is disposed of correctly, you will help to prevent potential negative consequences for the environment and human health. For more information, contact your installer or local authority.



It's strictly forbidden to smok near the unit

TABLE OF CONTENTS

1	PLI SERIES	p. 5	6.5.5	Dynamic limit maximum ventilation	p. 20
1.1	FIELD OF APPLICATION	p. 5	6.5.6	Power analyzer	p. 20
1.2	MAIN FEATURES	p. 5	6.5.7	Smart logic	p. 20
1.3	R454B (A2L) REFRIGERANT FLUID FEATURES ...	p. 5	6.5.8	Tanks probes management	p. 20
1.4	MODELS AND VERSIONS	p. 6	6.5.9	Antifreeze (heating element) protection management. ...	p. 20
1.5	MAIN COMPONENTS	p. 7	6.5.10	Outlet regulation	p. 20
1.5.1	Structure	p. 7	6.5.11	Defrost	p. 20
1.5.2	Electronic valve	p. 7	6.5.12	LAN	p. 21
1.5.3	Cooling circuit	p. 7	7	START-UP	p. 22
1.5.4	Refrigerant with low GWP	p. 7	7.1	PRELIMINARY CHECKS	p. 22
1.5.5	Customised hydraulic kit	p. 7	8	PLUMBING AND ELECTRICAL CONNECTIONS	p. 23
1.5.6	Electronic microprocessor control	p. 7	8.1	PLUMBING CONNECTION	p. 23
1.5.7	A2L gas leak detection systems	p. 7	8.1.1	General guidelines for plumbing connections	p. 23
1.5.8	Microchannels finned coil	p. 7	8.1.2	Recommended water circuit	p. 24
2	INSPECTION, CONVEYANCE DIMENSIONAL AND SITING	p. 8	8.1.3	Filling the system	p. 24
2.1	INSPECTION	p. 8	8.2	ELECTRICAL CONNECTIONS	p. 24
2.2	CONVEYANCE	p. 8	8.3	ELECTRICAL DATA	p. 26
2.3	SITING AND DAMPERS	p. 8	8.4	WATER CIRCUIT	p. 28
2.4	INSTALLATION CLEARANCE REQUIREMENTS AND DIMENSIONAL	p. 9	9	OPERATING LIMITS	p. 31
2.4.1	Condensate discharge from unit	p. 12	9.1	OPERATING LIMITS PLI C	p. 31
3	INSTALLATION SITE FEATURES	p. 13	9.2	OPERATING LIMITS PLI H	p. 32
4	WEIGHTS	p. 14	9.3	THERMAL CARRYING FLUID	p. 33
5	TECHNICAL FEATURES	p. 16	10	CONTROL AND SAFETY DEVICES	p. 34
5.1	PLI C WATER CHILLERS RATED TECHNICAL DATA	p. 16	10.1	CONTROL DEVICES	p. 34
5.2	PLI H HEAT PUMPS RATED TECHNICAL DATA	p. 17	10.1.1	Service thermostat	p. 34
6	MICROPROCESSOR CONTROL	p. 18	10.1.2	Control device settings	p. 34
6.1	DESCRIPTION OF CONTROL PANEL	p. 18	10.2	SAFETY DEVICES	p. 34
6.1.1	Remote control panels (accessories)	p. 18	10.2.1	Gas leak detection unit	p. 34
6.1.2	Main functions	p. 18	10.2.2	High pressure switch	p. 34
6.1.3	Devices controlled	p. 18	10.2.3	Low pressure switch	p. 34
6.2	USING THE CONTROL PANEL	p. 18	10.2.4	Anti-recycle timer	p. 34
6.2.1	Display	p. 18	10.2.5	Antifreeze thermostat	p. 34
6.2.2	Meaning of LEDs on the display	p. 18	10.2.6	Water differential pressure switch	p. 34
6.3	SWITCHING ON AND OFF AND CHANGING THE OPERATING MODE	p. 18	10.2.7	Water safety valve	p. 34
6.3.1	Switching the unit on and off in the cooling for chiller or heating mode for heat pump	p. 18	10.2.8	Safety device settings	p. 35
6.3.2	Changing the operating mode (heat pump only)	p. 19	11	ROUTINE MAINTENANCE AND CHECKS	p. 36
6.4	DISPLAY AND SETTING OF OPERATING PARAMETERS	p. 19	11.1	CHECKS TO BE PERFORMED BY THE USER	p. 36
6.4.1	Menu information	p. 19	11.1.1	Microchannels air condenser maintenance	p. 36
6.4.2	User Menu	p. 19	11.2	CHECKS AND MAINTENANCE TO BE PERFORMED BY SPECIALISED PERSONNEL	p. 36
6.4.3	Maintenance Menu	p. 19	12	COOLING CIRCUITS	p. 38
6.4.4	Manufacturer's menu	p. 19	13	TROUBLESHOOTING	p. 43
6.5	OTHER FUNCTIONS	p. 19	14	RETIRING THE UNIT	p. 45
6.5.1	Refrigerant leak alarm (not available for units with R410A)	p. 19			
6.5.2	Restart - Fast restart	p. 20			
6.5.3	Clock logic board	p. 20			
6.5.4	Partition of compressors power	p. 20			

1 PLI SERIES

1.1 FIELD OF APPLICATION

The PLI range units are designed for heating and cooling the water to be used in air-conditioning or process system, for residential, commercial or industrial. The PLI range units are intended for outdoor installation (IP24 protection degree), in a position not accessible to the public.

⚠ WARNING: Do not install the unit in environments with gas or flammable dusts.(ATEX zone)

1.2 MAIN FEATURES

PLI is Galletti's new range of air-cooled packaged chillers and heat pumps for outdoor installation featuring R454B refrigerant. R454B is a next generation A2L refrigerant with a GWP of only 467, one of the lowest on the market. This GWP value ensures that the PLI range complies with the gradual reduction of greenhouse gas emissions required by the F-GAS regulation, down to the stricter limits foreseen for 2030.

The range consists of 4 models with cooling capacities ranging from 35 to 50 kW, available in cooling only or reversible heat pump versions. The range's main strength is its high seasonal efficiency, which is designed to permanently reduce annual energy consumption as well as meet the minimum efficiency requirements established by ErP 2021.

Using the inverter compressors maximises seasonal efficiency and increases the unit's ability to accurately track thermal load. All models are equipped with electronic expansion valve which guarantees precise superheat control both in chiller and heat pump.

The use of top quality components at the cutting edge of technology in the cooling, hydraulic, and electrical systems makes PLI chillers state of the art in terms of efficiency, reliability, and operating limits.

In fact, the ability to produce water from -10 °C to 55 °C and operate at full load with outdoor air temperatures from -15 °C to 46 °C is guaranteed. The range provides high configurability from the point of view of acoustics, with a wide range of accessories designed to reduce noise emissions. Advanced control, which is always provided across the entire range, allows continuous monitoring of operating parameters, advanced regulation logics, and connectivity.

1.3 R454B (A2L) REFRIGERANT FLUID FEATURES

A2L gases are low flammability refrigerants with a flame propagation speed that is always less than 10 cm/sec (ASHRAE 34, ISO5149). By following the important precautions described in this manual and entrusting the operation of the units to qualified personnel only, installation and maintenance operations can be carried out in maximum safety, just like for class A1 HFCs. Refrigerant fluids are classified (under ASHRAE 34 and ISO5149 standards) according to their toxicity and flammability. They are classified according to a code consisting of a letter (indicating toxicity) and a number (indicating flammability), (e.g. A1). Initially, the classification is as follows:

— Toxicity:

A = refrigerants with an occupational exposure limit greater than or equal to 400 ppm

B = refrigerants with a limit lower than 400 ppm

— Flammability:

1 = no flame propagation under test conditions specified by the standard

2L = flame propagation with combustion speed ≤ 10 cm/s and calorific value < 19,000 kJ/kg

2 = flame propagation with combustion speed > 10 cm/s and calorific value < 19,000 kJ/kg

3 = flame propagation with combustion speed > 10 cm/s and calorific value ≥ 19,000 kJ/kg

HIGHER FLAMMABILITY	A3 R-50, R-170, R-290, R-600a, R-441a, R-1270	B3 R-1140
	A2 R-142b, R-152a	B2 R-30, R-40, R-611, R-717
LOWER FLAMMABILITY	A2L HFO-1234yf, HFO-1234ze	
NO FLAME PROPAGATION	A1 R-11-R-14, R-22, R-113, R-114, R-115, R-134a, R-410A, R-449B, R-1234zd	B1 R-10, R-21, R-123, R-764
		LOWER TOXICITY
		HIGHER TOXICITY

⚠ IMPORTANT: Since R454B gas refrigerant is heavier than air, one of the biggest dangers is its possible accumulation in confined spaces (manholes, storm drains, various recesses, underground spaces, etc.) and consequently the creation of an area with a potentially flammable atmosphere. Sources of ignition (sparks, high-temperature surfaces, open flames, etc.) may cause the ignition and spread of flames.

For other information refer to refrigerant fluid safety sheet.

1.4 MODELS AND VERSIONS

The range PLI consists of 4 models with cooling capacities from 35 to 50 kW, available as cooling only and reversible heat pump mode, charged with R454B fluid classified like A2L (slightly

» Configuration options

1	Expansion valve
A	Electronic
2	Water pump and accessories
0	Absent
1	Single standard pump
2	Double standard pump OR
3	Single HP pump
4	HP OR double pump
A	Single standard pump Inverter
B	Double standard pump Inverter OR
C	Inverter Single HP pump
D	HP OR inverter double pump
3	Partial heat recovery
0	Absent
D	Included with pump free contact
4	Air flow modulation
A	with EC Fans high pressure head
C	Phase-cut
E	with EC Fans
5	Antifreezing kit
0	Absent
E	Plate exchangers only
P	Plate exchanger + pump + expansion vessel
S	Plate exchanger + pump + expansion vessel and tank
6	Acoustic insulation and attenuation
0	Absent
3	Compressor compartment acoustic insulation and sound blanket

» Accessories

A	3 way valve for DHW production (water tank not allowed)
B	Outdoor finned coil heat exchanger protection grille
D	ON/OFF status of the compressors
E	Remote control for step capacity limit (advanced controller required)
F	Configurable digital alarm board (advanced controller required)
I	Refrigerant sensors
L	Water pipes additional insulation
M	0-10 V signal for external user pump control (on-board pump excluded)
N	Compressor tandem/trio isolation valves
P	DHW request from digital input
Q	Temperature probe for pump shutdown on the primary circuit
R	Enabling 2nd set-point / external alarm signaling via digital input
T	Energy metering kit
U	Unit lifting pipes
V	Set-point modification with 4-20mA signal

flammable)

NOTE: The choice of some options can make the choice of some others forbidden or make some selection (fields) mandatory. Please contact Galletti S.p.A. for verification.

7	Refrigerant pipework accessories
0	Absent
2	Operation limit extension low T air (Liquid separator in compressor intake + liquid injection)
8	Remote control / Serial communication
0	Absent
2	RS485 connection port (Modbus protocol or Carel)
B	BACNET IP/pCOWeb serial board
G	BACNET IP / pCOWeb serial board + supervision software
L	LON FTT10 serial board
S	Remote simplified control panel
X	Remote control panel for advanced controller
9	Special coils / Protective treatments
0	Copper-aluminium (standard heat pump only)
C	Cataphoresis
E	Microchannel in Long Life Alloy (standard for chiller)
I	Hydrophilic (heat pump only)
M	Microchannel with e-coating (chiller only)
P	Pre-painted fins with epoxy painting (only heat pump)
R	Copper-copper (heat pump only)
10	Base vibration dampers
0	Absent
G	Made of rubber
M	With spring
11	Outdoor coil trace heater
0	Absent
1	Present (heat pump only)
12	Onboard controller

1.5 MAIN COMPONENTS

Structure

Galvanised sheet steel structure treated with a polyester powder coating (RAL9002) suitable for outdoor applications, for an attractive look and effective resistance to corrosive agents.

Fastening devices are made of non-oxidizable materials, or carbon steel that has undergone surface-passivating treatments.

On request acoustic insulation can reduce the unit noise emissions

Fastening devices are made of non-oxidizable materials, or carbon steel that has undergone surface-passivating treatments.

Electronic valve

It is standard on the entire range and offers greater responsiveness during transients. The electronics also manage the synergistic operation of the compressors and the valve, thereby making it possible to vary overheating and maximize efficiency at partial loads.

Cooling circuit

- Inverter scroll type compressors configuration that can be sound insulated. The adopted components' efficiency, reliability, and noise emission levels represent the state of the art for scroll compressors.
- Brazed plate heat exchangers made of stainless steel and optimised for use with R454B.
- Finned block condenser with 5 mm copper piping and aluminium fins, characterised by circuits for optimize the operation both as evaporator and as condenser and to reduce refrigerant charge (PLI H).
- Microchannel condenser with low refrigerant charge (PLI C).
- Dehydrating filter.
- Flow indicator with humidity indicator.
- Cycle reversing valve (only PLI H)
- Check valve (PLI H)
- Liquid receiver (PLI H)
- High and low pressure switch
- Schrader valves for checks and/or maintenance
- Electronic expansion valve: this standard feature expands the liquid refrigerant towards the plate heat exchanger during operation in chiller mode and towards coils in heat pump mode.
- Liquid separator (PLI H): provides greater protection to the compressors against the return of liquids, especially during cycle reversals and defrosting.
- Gas leak detection systems: attends when there is a R454B leak, blocking operation of the unit.

Refrigerant with low GWP

Use of R454B refrigerant with low environmental impact. R454B is a next-generation A2L refrigerant with a GWP of only 467, one of the lowest on the market. This GWP value ensures that the PLI range complies with the gradual reduction of quotas of greenhouse refrigerants in the European market required by the F-GAS regulation, down to the stricter limits foreseen for 2030

Customised hydraulic kit

The hydronic kit is fully configurable. With standard pumps the maximum ethylene glycol concentrations is 25%. Contact the manufacturer in case you want to use greater percentage of glycol.

Electronic microprocessor control

The electronic control enables the complete control of the **PLI** unit. It can be easily accessed through a polycarbonate flap with IP65 protection rating.

By reading the outdoor air temperature, it can automatically change the setpoint to adapt it to the outdoor load conditions or keep the unit running even in the harshest winter conditions.

Main functions:

- Control of water returning from the system's temperature
- With modulating pump, control of the flow temperature to the unit or the Delta T
- Possibility of adapting the set-point to the outside load conditions or to the outside temperature
- Control of the electronic valve
- Complete alarm management, including history
- An RS485 serial port is available for monitoring
- Possibility of connecting a second remote terminal (display)
- Management of multiple units connected to a LAN network

Devices controlled

- Compressor
- Reverse cycle valve (PLI H)
- Alarm signalling relay
- LAN networks for controlling 6 units in parallel and managing BACNET and LON communication protocols

A2L gas leak detection systems

As a standard feature, the units are equipped with leak detection sensors near the cooling circuit. The microprocessor manages the procedures for securing and shutting down the unit in case of refrigerant leakage, also making it possible to divert the power supply of the control unit that collects the information from the leak sensors on a low-voltage emergency line. This function allows the complete disconnection of the power to the unit during maintenance operations, while leaving all the safety systems enabled.

Microchannels finned coil

The entire Chiller range has microchannel coils as a standard feature. The large heat exchange surface, the absence of a copper-aluminum interface, and the perfect flow of air make it possible to achieve the same performance while reducing the refrigerant charge by up to 40%, with obvious benefits from an ecological point of view. Galletti microchannel coils are made of Long Life Alloy, an aluminium alloy that offers maximum safety in urban and industrial environments.

For heat pumps there is a finned-coil exchanger with 5 mm copper tubes and aluminium fins.

2 INSPECTION, CONVEYANCE DIMENSIONAL AND SITING

2.1 INSPECTION

On receiving the unit, check that the packing is intact: the machine left the factory in perfect conditions and after thorough inspection.

Should you detect any signs of damage, immediately report them to the carrier and note them on the delivery slip.

Galletti S.p.A. Must be notified of the entity of the damage within 8 days of the delivery date.

Check that the following items are present:

- starting up module,
- wiring diagram
- warranty certificate
- make sure that this manual is intact (46 pagine).

2.2 CONVEYANCE

During handling it is compulsory to check dimensions, weights, centre of gravity and anchorages. Check as well that lifting and positioning devices conform to the current safety regulations. The unit leaves the factory screwed onto a wooden pallet, which allows it to be easily conveyed with a forklift truck. After removing the unit from the pallet, handle it gently, without applying excessive pressure on the side panels, finned coil and fan grille. You should collect and separate the packing materials (wood, cardboard, nylon etc.) and make them available for recycling in order to minimise their environmental impact. Before lifting, remove the screws fastening the base of the unit to the wood platform.

The unit must be lifted using $\varnothing 1''$ steel pipes at least 5mm thick, to be inserted in the round holes on the base side members (see figure) and identified by means of stickers. Piping must protrude of at least 250-300 mm from each side, be slung with ropes of equal length and secured to the lifting hook (provide stops at the ends of the pipes to prevent the ropes from slipping off due to the weight).

Use ropes and belts sufficiently long to extend beyond the height of the machine and place spacer bars and boards on the top to prevent damaging the sides and the top of the unit.

In this phase, before the definitive position, vibration damping supports can be installed (optional).

⚠ WARNING In all lifting operations make sure that the unit is securely anchored in order to prevent accidental falls or overturning.

⚠ WARNING Use all available lifting points!

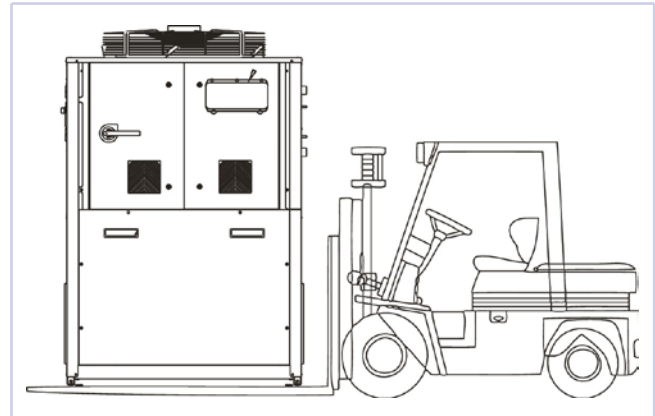

» Lifting points PLI

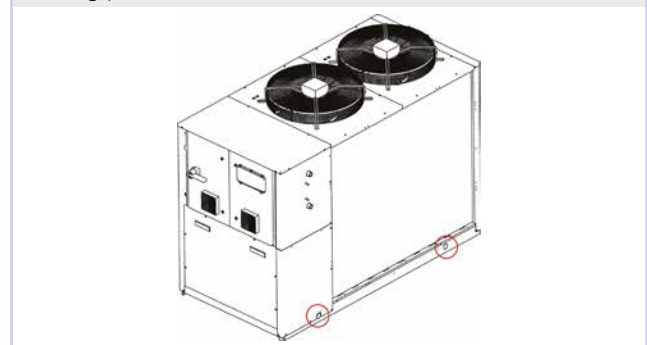

2.3 SITING AND DAMPERS

It is important to bear in mind the following aspects when choosing the best site for installing the unit:

- Size and origin of water pipes;
- Location of the power supply;
- Solidity of the supporting surface;
- Avoid obstacles to the outflow of air from the fan which could cause back suction (see section on 2.4 Installation clearance requirements and dimensional p. 9);
- Direction of prevalent winds: (position the unit so as to prevent prevalent winds from interfering with the fan air flow). Prevalent winds opposing the fan air flow will result in a maximum air temperature below the value indicated in the operating limits;
- Avoid the possible reverberation of sound waves; do not install the unit in narrow or cramped spaces;
- Ensure adequate accessibility for maintenance or repairs (see section on 2.4 Installation clearance requirements and dimensional p. 9).

This appliance is not intended to be used by children or persons with physical, sensorial or mental problems, inexperienced or unprepared, without supervision. Be careful that children do not approach the appliance.

For the installation instructions refer to instruction manual RG66013698 supplied with unit.

PLI	DAMPERS
F1	4
F2	4

2.4 INSTALLATION CLEARANCE REQUIREMENTS AND DIMENSIONAL

To guarantee the proper functioning of the unit and access for maintenance purposes, it is necessary to comply with the minimum installation clearance requirements shown in dimensional drawings.

Verify that there are no obstacles in front of the fans air outlet.

- Avoid any and all situations of backflow of hot air between air outlet and inlet of the unit.
- If even only one of the above conditions is not fulfilled, please contact the manufacturer to check for feasibility.
- In the design of the PLI series, special care has been taken to minimise noise and vibrations transmitted to the ground.
- Even greater insulation may be obtained, however, by using vibration damping base supports (available as optional accessories).
- If vibration damping base supports are adopted, it is strongly recommended also to use vibration damping couplings on the water pipes.
- Whenever the unit is to be sited on unstable ground (various types of soil, gardens, etc.) it is a good idea to provide a supporting base of adequate dimensions.

 **WARNING** During installation adjust the vibration damping couplings in order to allow a proper slope toward the condensate drainage system, as shown on the unit.

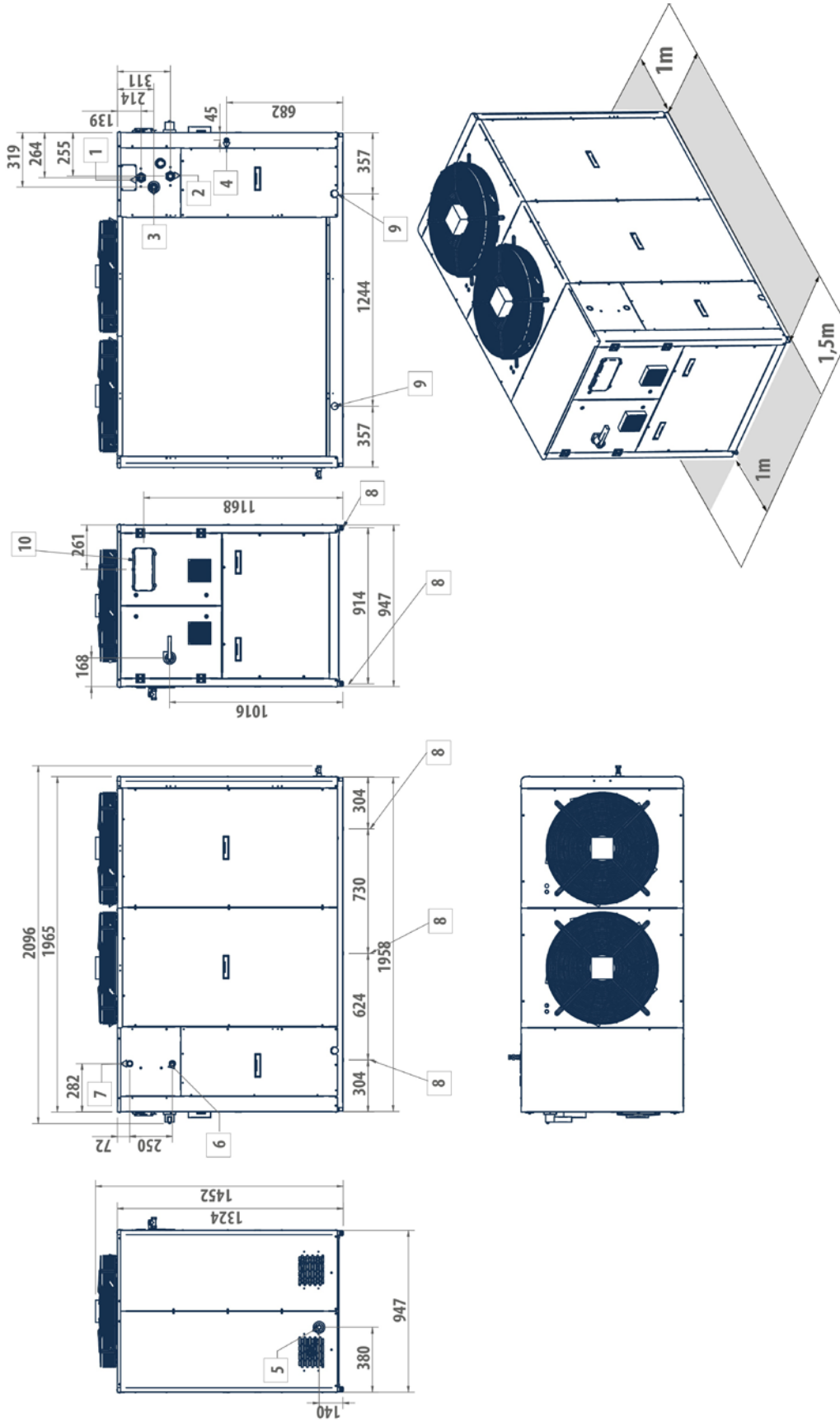

- Legend**
- 1 Water inlet/Victaulic 1 1/4 " F
 - 2 Water outlet/Victaulic 1 1/4 " F
 - 3 Water supply 1/2 " M (optional tap)
 - 4 Power supply
 - 5 Water drainage tank 1/2 " F
 - 6 Heat exchanger inlet 1 " M
 - 7 Heat exchanger outlet 1 " M
 - 8 Vibration dumpers
 - 9 Lifting points
 - 10 User interface

» PLI 040-045-050

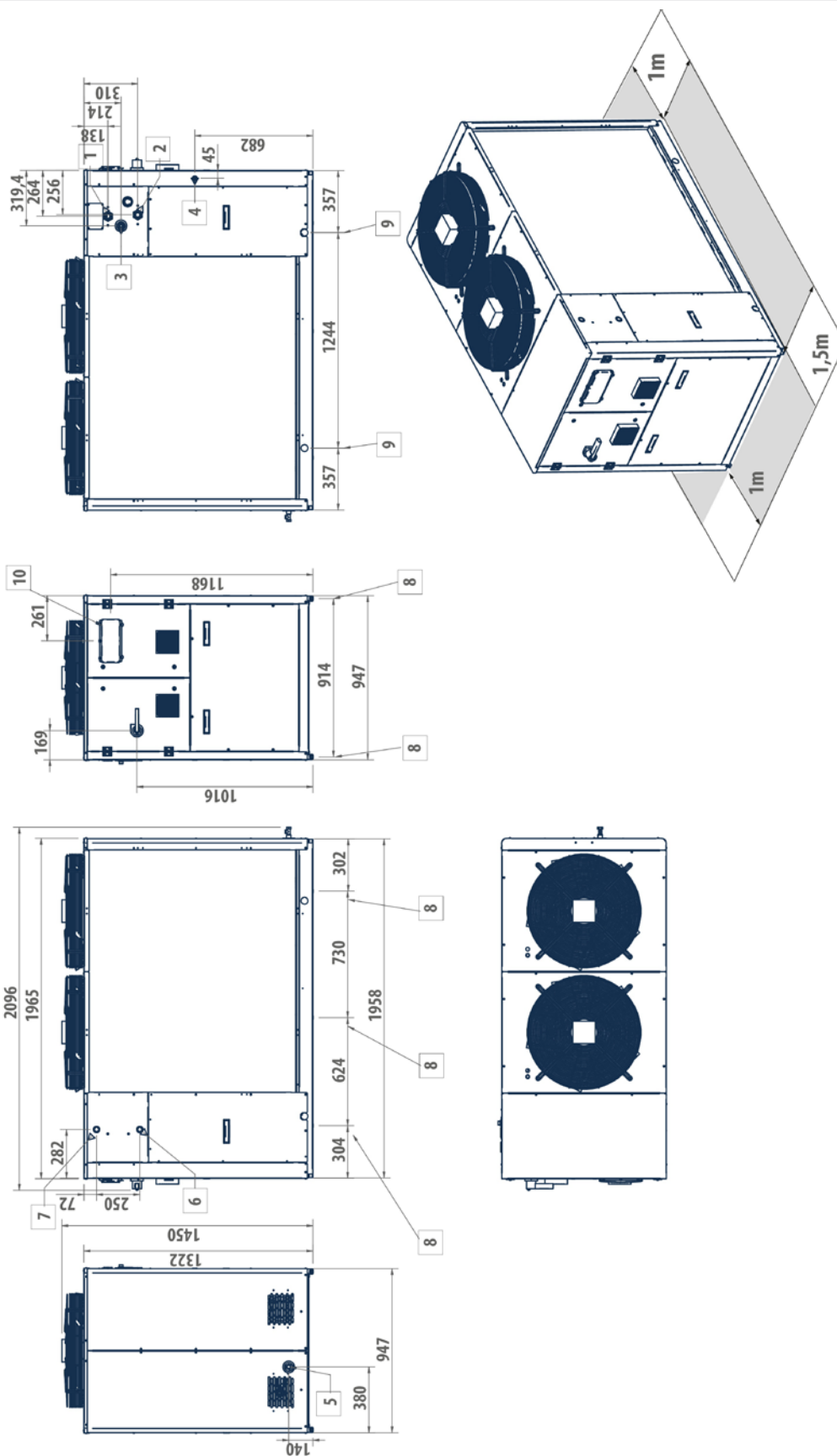

Legend

- 1 Water inlet Victaulic 1 1/4" F
- 2 Water outlet Victaulic 1 1/4" F
- 3 Water supply 1/2" M (optional tap)
- 4 Power supply
- 5 Water drainage tank 1/2" F
- 6 Heat exchanger inlet 1" M
- 7 Heat exchanger outlet 1" M
- 8 Vibration dumpers
- 9 Lifting points
- 10 User interface

2.4.1 Condensate discharge from unit

During normal operation of the unit as a heat pump, condensate is produced due to the dehumidification of the air in contact with the finned block heat exchanger.

In order to hold the condensate that the unit normally produces during operation in winter mode (and during defrosting), it is advisable to prepare a technical tank below the base of the unit, with sufficient capacity to collect and discharge the water produced. The adoption of a drip tray may be mandatory (check the local legislation in force) in case of the use of glycol or additives such as ethylene glycol that cannot be released into the environment in case of possible leakage of the circuit. The installer is responsible for the construction of such a drip tray.

3 INSTALLATION SITE FEATURES

The units of the PLI range are designed for outdoor installation, in a context where the natural dilution of the refrigerant that could escape as the result of a leak guarantees a degree of safety.

⚠ IMPORTANT: The unit should NOT be installed below ground level (in a depression) or where a leak could result in the accumulation and formation of an explosive atmosphere. Therefore, within a radius of 3 metres around the unit (distance measured from the outside wall of the unit), there must be no accumulation (manholes, storm drains, or recesses) or pathways through which the refrigerant can flow into a building or to an accumulation point or other dangerous access points (e.g. fresh air inlets for air conditioning or ventilation systems).

In addition, there must be NO sources of ignition of any kind whatsoever located within the buffer zone specified above. Therefore, it is necessary to avoid open flames, electrical equipment that produces sparks (with the exception of ATEX components with appropriate safety characteristics, i.e. ATEX-compliant components for group IIA gases under IEC 60079-15), hot surfaces, cell phones, and any other possible sources of ignition. If this is not possible, a specific risk analysis should be carried out in order to identify countermeasures capable of eliminating the risk of fire in the event of leakage of refrigerant.

⚠ WARNING: If it is necessary to install the unit in a closed space, it must have all the characteristics of a machine room as defined in standard EN 378-3

In these cases a specific assessment must be carried out by a competent technician, in compliance with local regulations on safety and the use of flammable fluids in buildings; if no specific local regulations exist, it is advisable to use the above-mentioned standard as a reference. The following are some general guidelines.

A machine room as defined by EN378 must have a ventilation system capable of keeping the concentration of the refrigerant under 50% of the lower flammability limit in case of leakage.

A machine room may not be used as occupied space; access to it will be allowed only to qualified personnel who have been trained for the maintenance and operation of the equipment and system.

A machine room may not be used as a warehouse for flammable materials or refrigerant for the unit. A2L fluids may only be stored in compliance with local fire regulations.

- No open flames are permitted, except for maintenance work which, in any case, can only be carried out according to safety procedures (see relevant section) and with additional forced ventilation. No sources of ignition are permitted
- Any surface that may come into contact with a flammable gas leak must never have a temperature higher than the auto-ignition temperature (100 °C).
- An emergency stop switch must be provided inside and outside the machine room in an easily accessible position.
- All ducts and pipes passing through the machine room should be properly sealed to prevent seepage.
- Always provide a system of refrigerant leakage sensors with adequate sensitivity to the lower flammability limit of the fluid

⚠ WARNING: In any case, the requirements listed above not be understood as a derogation from carrying out a risk analysis and detailed design pursuant to the requirements of standard EN378 (or other local regulations in force, in relation to machine rooms for units containing A2L fluids)

In any case, avoid installing the units in locations that could be dangerous during placement, start-up, operation, and maintenance operations, such as areas without adequate protection against falls, areas with obstacles that create a danger of tripping or falling, and areas with buffer spaces that are not compliant with the documentation.

4 WEIGHTS

This drawing shows the points of the machine for which weights have been calculated, with respect to the basic chiller and heat pump model. The weights are shown in the tables below.

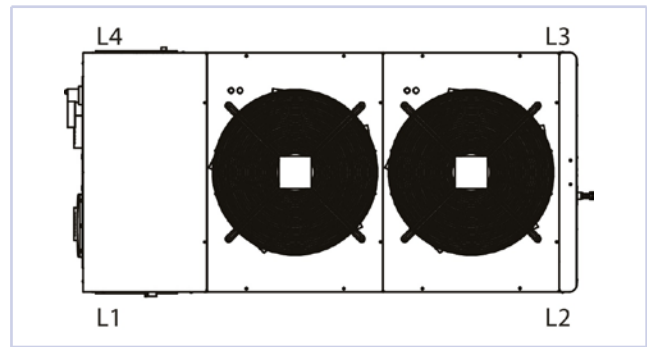
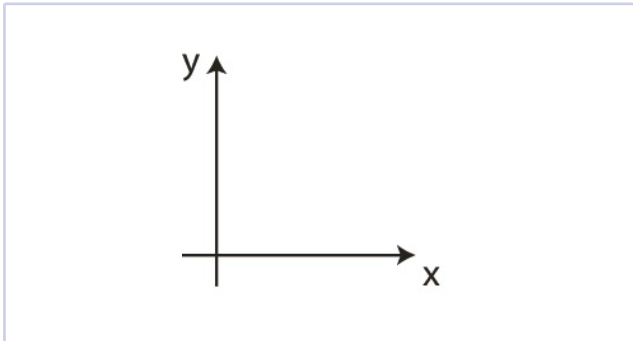

» Lifting center of gravity for transporting unit C version without hydraulic options

PLI		035	040	045	050
Xb	mm	1010	1015	1015	1015
Yb	mm	500	490	485	485

» Lifting center of gravity for transporting unit H version without hydraulic options

PLI		035	040	045	050
Xb	mm	1000	1010	1010	1010
Yb	mm	495	485	480	480

» Lifting center of gravity for transporting unit C version with pump and tank

PLI		035	040	045	050
Xb	mm	970	980	980	980
Yb	mm	500	490	485	485

» Lifting center of gravity for transporting unit H version with pump + full tank

PLI		035	040	045	050
Xb	mm	1010	1015	1015	1015
Xb	mm	970	980	980	980

Important note: the weights of the hydronic modules must be added to the standard weights of the respective basic model (cooling only and heat pump).

All weights stated below include the refrigerant charge as well as the water contained in the circuit (very important when

assessing the most suitable bearing surface for the unit especially in the presence of a tank).

To get an approximate estimate of the unit's weight when empty, subtract the weight (in kg) of the water contained in the tank. In other cases the water content is negligible for these purposes.

» Operating weight C version without hydraulic options

PLI		035	040	045	050
L1	kg	121	126	134	134
L2	kg	75	77	83	83
L3	kg	71	69	71	71
L4	kg	137	138	145	146
Total	kg	405	409	433	434

» Operating weight H version without hydraulic options

PLI		035	040	045	050
L1	kg	122	127	135	136
L2	kg	77	80	85	85
L3	kg	71	69	71	71
L4	kg	137	138	146	146
Total	kg	407	413	438	438

» C - 1 pump version weight distribution with full inertial tank

PLI		035	040	045	050
L1	kg	156	160	169	169
L2	kg	127	129	135	135
L3	kg	123	121	123	123
L4	kg	172	172	180	180
Total	kg	578	583	607	607

» Operating weight H version with pump and full buffer tank

PLI		035	040	045	050
L1	kg	157	161	170	170
L2	kg	129	132	137	137
L3	kg	123	121	123	123
L4	kg	172	172	181	181
Total	kg	581	586	611	612

5 TECHNICAL FEATURES

5.1 PLI C WATER CHILLERS RATED TECHNICAL DATA

» PLI C water chillers rated technical data

PLI			035	040	045	050
Power supply		V-ph-Hz	400-3N-50			
Cooling capacity	(1)	kW	36,6	43,1	48,4	53,4
Total power input	(1)	kW	12,3	14,3	15,6	17,8
EER	(1)		2,97	3,01	3,10	3,00
SEER	(2)		5,04	5,17	5,28	5,21
Air flow rate	(1)	m ³ /h	15200	19200	19000	19000
Water flow	(1)	l/h	6295	7413	8325	9185
Water pressure drop	(1)	kPa	32	35	42	38
Available pressure head - LP pumps	(1)	kPa	138	105	90	72
Available pressure head - HP pumps	(1)	kPa	218	195	178	157
Buffer tank volume		dm ³	125	125	125	125
Maximum current absorption		A	44,0	46,0	49,0	50,0
Start up current		A	60	60	60	60
Startup current with soft starter		A	49	49	49	49
Compressors / circuits			1/1			
no. of axial fans			2			
Height		mm	1452	1452	1452	1452
Depth		mm	965	965	965	965
Length		mm	2100	2100	2100	2100
Sound power level	(3)	dB(A)	82	84	84	85
Sound power level, low-noise version	(3)	dB(A)	79	81	81	82
Weight without options		kg	409	403	427	428
Maximum transport weight		kg	467	462	486	488

(1) Outdoor air temperature 35°C, water temperature 12°C / 7°C (EN14511:2018)

(2) η efficiency values for heating and cooling are respectively calculated by the following formulas: $[\eta = SCOP / 2,5 - F(1) - F(2)]$ e $[\eta = SEER / 2,5 - F(1) - F(2)]$. For further information, please refer to the technical document "ErP 2009/125/EC DIRECTIVE" in the catalogue introducing pages, or to the EN14825:2017 regulation.

(3) Sound power level measured according to ISO 9614

5.2 PLI H HEAT PUMPS RATED TECHNICAL DATA

» PLI H Heat pumps rated technical data

PLI			035	040	045	050
Power supply		V-ph-Hz	230-1-50			
Cooling capacity	(1)	kW	33,6	39,7	44,9	49,1
Total power input	(1)	kW	13,0	15,3	16,3	18,8
EER	(1)		2,58	2,59	2,75	2,61
SEER	(2)		4,12	4,40	4,57	4,56
Water flow	(1)	l/h	5779	6828	7723	8445
Water pressure drop	(1)	kPa	30	32	39	35
Available pressure head - LP pumps	(1)	kPa	140	108	92	75
Available pressure head - HP pumps	(1)	kPa	220	200	180	160
Heating capacity	(3)	kW	35,7	44,6	48,8	53,9
Total power input	(3)	kW	12,1	14,3	15,3	17,1
COP	(3)		2,95	3,12	3,19	3,15
SCOP	(2)		3,40	3,81	3,99	4,07
Heating energy efficiency class	(4)		A+			
Water flow	(3)	l/h	6140	7671	8394	9271
Water pressure drop	(3)	kPa	35	39	42	40
Available pressure head - LP pumps	(3)	kPa	121	91	70	60
Available pressure head - HP pumps	(3)	kPa	200	170	158	140
Air flow rate	(3)	m ³ /h	17500	20200	19900	19900
Start up current		A	60	60	60	60
Startup current with soft starter		A	49	49	49	49
Compressors / circuits			1/1			
no. of axial fans			2			
Buffer tank volume		dm ³	125	125	125	125
Refrigerant charge	(5)	kg	3,90	4,60	5,70	6,70
Height		mm	1452	1452	1452	1452
Depth		mm	965	965	965	965
Length		mm	2100	2100	2100	2100
Sound power level	(6)	dB(A)	83	85	85	86
Sound pressure level - low noise execution	(7)	dB(A)	80	82	82	83
Weight without options		kg	411	406	431	433
Maximum transport weight		kg	470	465	490	492

(1) Outdoor air temperature 35°C, water temperature 12°C / 7°C (EN14511:2018)

(2) η efficiency values for heating and cooling are respectively calculated by the following formulas: $[\eta = SCOP / 2,5 - F(1) - F(2)]$ e $[\eta = SEER / 2,5 - F(1) - F(2)]$. For further information, please refer to the technical document "ErP 2009/125/EC DIRECTIVE" in the catalogue introducing pages, or to the EN14825:2017 regulation.

(3) Outdoor air temperature dry bulb 7°C / wet bulb 6°C, water temperature 40°C / 45°C (EN14511:2018)

(4) Seasonal energy efficiency class for LOWTEMPERATURE room heating under AVERAGE climatic conditions [EUROPEAN REGULATION No 811/2013]

(5) Kg gas value is estimated. For the exact value refer to the plate data on the unit.

(6) Sound power level measured according to ISO 9614

(7) Sound pressure measured at a distance of 10 m in a free field with a directivity factor of 2

6 MICROPROCESSOR CONTROL

Below are specified the microprocessor control functions in the basic version.

The advanced control instructions are described in service manual.



6.1 DESCRIPTION OF CONTROL PANEL

The unit's control panel allows you to display and set the unit's operating parameters and read the main operating data. In addition it indicates what mode (cooling or heating) the unit is operating in and signals any alarms that may have been triggered. In addition to this, on the default screen it is possible to read some values read by the probes and the status of the main devices of the unit such as the compressors.

All settings are memorised in the circuit board and used when the system is switched back on, even after a power failure.

6.1.1 Remote control panels (accessories)

Installing a PCDS remote control panel enables you to switch the unit on and off, set the operating mode (cooling - heating) remotely, and have a cumulative alarm indicator (thanks to an alarm signalling relay integrated in the electronic control device). Installing a PGD remote control panel instead makes it possible to access all the electronic control functions on the unit.

6.1.2 Main functions

- Water temperature control according to the required setting
- Control of pumps (both on/off and inverter) outside the unit
- Complete alarm management (storage of history)
- Designed for serial line connection for monitoring / remote support
- Designed for connection to a remote terminal that duplicates the electronic control functions
- Designed for LAN connection (for more information see the dedicated manual)

6.1.3 Devices controlled

- Compressors
- Cycle reversing valve (heat pump versions only)
- Water circulation pumps (if present)
- Electronic expansion valve driver (if present)
- Alarm signalling relay inside the electronic controller (designed to control a warning light or buzzer)
- ...
- All other devices that are relevant for the operation of the unit are indicated on the wiring diagram

6.2 USING THE CONTROL PANEL

6.2.1 Display

The graphic display shows the plate heat exchanger inlet and outlet water temperature. In addition to this, you can see the main information regarding the status of the unit.

SYMBOL	KEY	DESCRIPTION
	ALARM	Press the ALARM key to reset alarms. When there is an alarm, it will light up.
	PROGRAM	Press PRG to access the main menu.
	ESC	Press ESC to move up to a higher level in the menu.
	UP	Press UP to go to the next screen or increase the value of a parameter.
	ENTER	Press ENTER to go into the fields of parameters to be edited and to confirm changes.
	DOWN	Press DOWN to go to the previous screen or decrease the value of a parameter.

6.2.2 Meaning of LEDs on the display:

The red LED on the alarm button indicates that a serious alarm is in progress. The yellow LED on the central button to the left indicates that a non-serious alarm is in progress.

6.3 SWITCHING ON AND OFF AND CHANGING THE OPERATING MODE

The unit may be switched on and off from the control panel installed on the unit itself or by remote.

6.3.1 Switching the unit on and off in the cooling for chiller or heating mode for heat pump

To switch the unit on and off in both operating modes, follow the instructions below:

- Press the UP key or the DOWN key to access the quick menu
- Move the cursor to the change mode symbol and press ENTER
- Follow the on-screen instructions to selected the desired operating mode
- Press ESC
- Move the cursor to the power-on symbol and press ENTER
- Follow the on-screen instructions to turn the unit on in the

preselected operating mode (press PRG when indicated)
Switchover mode from cooling to heating is unavailable on cooling only units or motor-driven evaporating units.

6.3.2 Changing the operating mode (heat pump only)

To enable remote ON-OFF switching from the PCDS or via an external switch (not supplied) make connections to terminals indicated on wiring diagram (normally jumpered).

Remote **ON-OFF** open: unit OFF (keyboard disabled)

Remote **ON-OFF** closed: unit ON (possibility to switch the unit ON and OFF from the keyboard)

⚠ WARNING Where remote ON-OFF switching is enabled, after a power failure occurs and power is restored the unit will go into the mode indicated by the remote input without considering any changes that have been made from the unit control panel. That is:

remote **ON-OFF** open: the unit remains Off

remote **ON-OFF** closed: the unit starts again

The unit leaving the factory has been configured for a fast, easy connection to the PCDS remote control (accessory), which enables the user to change the operating mode and turn the unit on and off from a distance.

If the unit is not equipped with this accessory, to select the operating mode it is necessary to use terminals 19-30 on the electric control board as follows:

- terminals 19-30 closed for cooling
- terminals 19-30 open for heating

⚠ WARNING: Only specialised personnel may access the electric control board.

Changing the operating mode is unavailable on cooling only units or motor-driven evaporating units.

6.4 DISPLAY AND SETTING OF OPERATING PARAMETERS

Once on the main page, press the UP or DOWN key to display the quick menu. In the quick menu there are 4 items identified by a symbol:

- Switch-on unit
- General information about the software
- Set-point and basic temperature control
- Access to advanced menu



All items in this menu are freely accessible. If you select access to the advanced menu, you must enter your password. Depending on the password entered, you can access various types of parameters. The main menu is divided into 4 blocks, each identified by a symbol:

- Unit status information (free)
- User menu (password 000100)
- Maintenance technician menu (000118)
- Manufacturer's menu (password private)



6.4.1 Menu information

In this menu you can find all the information regarding the operation of the unit, such as:

- Status of all inputs and outputs
- Status of all the unit's devices (e.g. compressors, valve, etc.)
- LAN Status
- ...

6.4.2 User Menu

In this menu you can find the parameters useful to the user in order to use the unit according to the requirements of the system. The following are the parameter categories available:

- Temperature control
- Remote control settings
- Settings for communication with BMS
- ...

6.4.3 Maintenance Menu

In this menu you can find the parameters useful to the maintenance technician for properly managing and maintaining the unit. The following are the parameter categories available:

- Alarm history
- Non-serious alarm settings
- I/O forcing
- Operating hours counter
- LAN settings
- ...

6.4.4 Manufacturer's menu

In this menu you can find the parameters useful to the manufacturer for properly configuring the unit. The parameters contained within it concern the construction and functional version of the unit. In addition to this, the rules for serious alarms and operation of all the unit's devices are set here. These parameters must not be modified for any reason by the end user or the maintenance technician unless explicitly instructed to do so by the manufacturer.

6.5 OTHER FUNCTIONS

6.5.1 Refrigerant leak alarm (not available for units with R410A)

The function is activated only when there is a control unit with gas leak detection sensors.

The refrigerant leak alarm (activated by a double level gas leak sensor) has two thresholds. The first threshold (called "gas warning") produces a NON-LOCKING alarm that by default has an activation delay of 15 seconds (automatic reset) and causes the "PRG" key to light up with a yellow LED, as is the case for all warnings. The second threshold (called "gas leak") produces a LOCKING alarm that by default has an activation delay of 0 seconds (manual reset) with the following effects:

- Key «alarm» switched on with red LED, as all alarms

- Total unit switching off
 - Activation of forced ventilation of electrical board
- The alarm can only be reset if the sensor no longer detects the presence of refrigerant in the air above the alarm threshold.

6.5.2 Restart - Fast restart

When the power supply to the unit is interrupted, the card can store the status it is in (on/off - sum/win - set-point), and when power is restored, it starts again in the same mode. When restarting, the compressor activation time is taken into account. Fast restart is a function suitable for data centre or process installations. It is not recommended to enable it in other cases, which is why it cannot be enabled by default. With fast restart, when power is restored, the compressors are not subject to the delay times.

6.5.3 Clock logic board

The pCO5+ board has an integrated clock card by default, so that time slots can be managed locally for the unit or for individual devices. The software can also handle daylight saving time.

6.5.4 Partition of compressors power

During card programming the percentage of cooling capacity generated by each individual compressor is configured in the software. In this manner the differential is distributed in proportion to the power generated.

EXAMPLE: Unit with 2 compressors, one of which has three times the power of the other

Cmp1 = 75%

Cmp2 = 25%

Differential 2°C

Cmp2 is switched on at half a degree from the set point, while cmp1 is switched on at 2°C from the set point. The same thing happens when approaching the set point.

 **NB:** the compressors can be disabled by parameter. When this operation is carried out, however, it is necessary to distribute the power among the missing compressors so that the total is 100%.

6.5.5 Dynamic limit maximum ventilation

It is possible to activate a double maximum ventilation percentage threshold via a parameter (obviously with different settings for summer and winter, in relation to evaporation and condensation).

This second threshold can be activated on the basis of:

- Time schedules (es. Night noise reduction)
 - Digital input
- External air temperature (es. if necessary overboost activation)

6.5.6 Power analyzer

A power analyser can be installed to monitor all the electrical values of the unit, such as currents, voltages, frequencies, power, cos phi, etc., from the PGD display of the pCO5+.

The data collected can also be consulted via supervisor.

6.5.7 Smart logic

Smart logics are custom functions to activate by software

As input can be used analog/digital input of pCO5+ or pCOE/EVD

Available logic functions are: AND, OR, IMPULSE, TIMER, HYSTERESIS, ...

The output signal (if is analog or digital) can be bring on pCO5+/pCOE output

6.5.8 Tanks probes management

The software offers the possibility of installing a tank sensor for each device. Once the tank sensor is installed, the main regulation is switched from the return temperature to the tank temperature. The sensor is optional.

6.5.9 Antifreeze (heating element) protection management

Antifreeze protection is provided by two devices: the pump and antifreeze heating elements.

These two devices are regulated on the basis of two parameters: outdoor air temperature and outlet water temperature. In addition to this, the time variable is involved in the regulation.

When the unit is switched ON, the heating elements are NEVER ACTIVATED because protection is provided by the pump, which is always on and therefore keeps the water moving by discharging a small amount of heating capacity into the system.

If the unit enters an alarm state, it is considered to be OFF DUE TO ALARM; therefore, the heating elements switch on, if required.

When the unit is switched OFF, on the other hand, an outdoor air temperature SET POINT must be set (with hysteresis) below which the process is active.

When the procedure is active the following items are activated:

- Pump: based on a chosen timing (e.g. 2 minutes every 10). In the case of an inverter pump, it is also possible to select the speed at which the pump will run when it is switched on.
- Antifreeze heating elements: based on a thermostat setting (set point with hysteresis) on the outlet water sensor side.

6.5.10 Outlet regulation

Outlet regulation can be obtained with two different ways:

- Pure outlet regulation
- Indirect outlet regulation got with modulating pump

PURE OUTLET REGULATION

The compressors are switched off with the standard logic (set point and differential divided on the compressor power), but the relevant temperature is the flow temperature and not the return temperature. The control can be set in various ways (P, PI, etc.) in order to avoid sudden starts/stops. It can only be used in units with a stable thermal load and a high number of compressors (certainly not in tandem configurations), otherwise the temperature control would be unstable.

INDIRECT OUTLET REGULATION GOT WITH MODULATING PUMP

In this case, the main regulation of the unit (the one that turns the compressors on and off) is carried out in the conventional way on the return water temperature. The number of compressors turned on therefore depends on the distance from the inlet water temperature set point.

At the same time, however, the modulating pump varies its speed in order to keep the flow temperature at a fixed temperature. The pump will therefore have a lower speed when the number of compressors switched on is lower and a higher speed when it is higher. This system is more stable than the previous one and is the one that is recommended.

6.5.11 Defrost

Defrosting cycle happens according to the logic:

1. Activation of the cycle when the evaporation pressure is below a certain threshold for a certain amount of time
2. PRE-DEFROST PHASE with compressors stopped, fans stopped, and switching of the 4-way valve at half of the time
3. DEFROST PHASE starting up the unit in chiller mode with fans off until the cycle exit pressure threshold (or the maximum

cycle time) is reached

4. POST-DEFROST PHASE with compressors stopped and ventilation switched on in order to eliminate water droplets from the coils. Switching of the 4-way valve at half of the time

WARNING: The following section concerning separate defrosting between the various cooling circuits is to be considered valid and can only be implemented on units with separate series of fans (V-shaped coil geometry or fan compartment separator).

In doublecircuits units can be setted the following parameters:

DEFROSTING LOGIC:

Total. when one of the two circuits requires defrost, the cycle is carried out by both

Separated: the cycle works independently from each cycle

DEFROSTING MODE:

Simultaneous: the defrost cycles of circuit can be overlapped.

Sequential: the defrost cycles of circuits even if called in the same moment, can be overlapped and one of them is «slipped» after the other.

These parameters must NOT be modified by the CAT/CUSTOMER without first consulting the parent company.

6.5.12 LAN

Lan (Local Area Network) is a set of integrated functions for optimising the regulation of systems with at least 2 chillers. This function happens thanks to control board pCO5+ electrical connections.

The port used for the LAN (PLAN) is supplied as standard on the pCO5+ boards, therefore the function hasn't an additional cost except for the electrical connection on site (twisted and shielded data cable is recommended).

In any LAN network there will be just a unit master which:

- Receives operating data from other slave units
- Processes the received data and on the basis of the chosen control logic decides how many and which machines/compressors to start
- Sends commands to slave units
- In all LAN network is possible to configure the master display like, with a simple pushing buttons, display for all slave.

Below a summary of various available logics:

For more information about LAN management see the dedicated NCS manual.

Logic	Number of unit to start	System probe	Step type	Compressors regulation	Compatibility with multifunction	Arrangement
Time rotation	Fixed according to the operating mode	No	Machine	Stand alone	Yes	Working hours
Macro step	Variable based on temperature setpoint and load	Tank (2 multifunctions)	Machine	Stand alone		Work hours and priorities
Load stand alone	Variable according to load	No	Machine	Stand alone		Work hours and priorities
Load global	Variable based on temperature setpoint and load	1 on machine return line 1 on system delivery line	Machine	Stand alone	No	Work hours and priorities
Cascade	Variable based on system PID	Selecting between: System return or delivery, or Master input or output, or Average of machine inputs or outputs	Compressor	Centralised from master		Working hours and priority level/load level of the machine
Step control	Variable based on system PID	Selecting between: System return or delivery, or Master input or output, or Average of machine inputs or outputs	Compressor	Centralised from master		Working hours and priority level/load level of the machine
Cascade & step	Variable based on system PID	Selecting between: System return or delivery, or Master input or output, or Average of machine inputs or outputs	Compressor	Centralised from master		Working hours and priority level/load level of the machine

7 START-UP

The first start up must be carried out exclusively by qualified personnel and authorized by Galletti S.p.A. (see warranty sheet attached).

At first start-up of the installation make sure to comply with current national regulations.

7.1 PRELIMINARY CHECKS

When starting up the unit for the first time or after a seasonal period of quiescence, it is advisable to have the following checks performed by specialised personnel:

- Check that the electrical connections have been made properly and that all the terminals are securely tightened.
- Check that the external power supply is within +5 % tolerance from the power supply reported on the unit identification label. If the power supply is subject to frequent voltage fluctuations, contact Galletti S.p.A. for advice on choosing suitable protections.
- Check for refrigerant leaks, with the aid of a leak detector if necessary
- Check that the plumbing connections have been properly made according to the indications given on the plates to be found on the unit itself (water inlet, water outlet etc.).
- Make sure that the pump is not blocked.
- Make sure that the water circuit is duly bled to completely eliminate the presence of air: load the circuit gradually and open the air vent valves, which the installer should have set in place.

In order to avoid soiling that could result in the breakage of the plate heat exchangers and hydronic pumps, it is necessary to wash the hydraulic system properly, before allowing water to circulate inside the unit. More specifically:

1. The hydraulic system must be flushed out, with a flow of water (which is then to be disposed of) and without passing through the filter at the inlet of the unit, in order to eliminate large-diameter impurities, debris, and any dirt present as residue from the work carried out (e.g. welding). Continue flushing until the water (to be disposed of) becomes clear.
2. The system can then be connected to the chiller, on which the inlet water filter must be installed. In this phase it is necessary to let the water circulate inside the unit (through the filter) without starting the compressors in any case. Perform

this operation for a sufficient time to allow the water to circulate in the system a few times.

3. At the end of the previous phase, clean the inlet filter, refit the cartridge in place, and circulate the water by starting the unit. In case of a flow alarm, check whether there is air in the circuit.

The fluid in the hydraulic circuit must not contain:

- dirt or solids in suspension;
- acids or bases or corrosive liquids in general;
- sea water;
- liquids that are flammable and generally dangerous.

CAUTION: during the start-up phase, maximum attention must be paid to the filling pressure of the system and in particular to the pressure of the intake water to the pump (under operating flow rate conditions) in order to AVOID CAVITATION phenomena that could seriously compromise the reliability of the pump. The intake pressure value must be higher than the minimum value indicated in the paragraph 8.1.3

Filling the system. The cavitation phenomenon can also be identified by the anomalous noise produced by the pump when it is running; this noise disappears if the pressure returns to its proper value.

WARNING: before starting the unit, make sure all the covering panels are in place and secured with the fastening screws provided. To start the unit, move the main switch to on. Use the keypad of the electronic control as directed in section p. 26 to select the cooling or heating mode.

ATTENZIONE: You should not disconnect the unit from the power supply during periods when it is inoperative but only when it is to be taken out of service for a prolonged period (e.g. at the end of the season). To turn off the unit temporarily follow the directions provided in the section p. 26.

WARNING: do not cut off power using the main switch: the latter device serves to disconnect the unit from the power supply when there is no passage of current, i.e. when the unit is already turned OFF.

WARNING: BEFORE OF THE START UP OF THE UNIT MAKE SURE TO REMOVE THE PLASTIC CAPS WHICH ARE PROTECTING THE GAS SENSORS AND THE REFRIGERANT SAFETY VALVE.

8 PLUMBING AND ELECTRICAL CONNECTIONS

8.1 PLUMBING CONNECTION

All units in the PLI series are equipped with water flow switch, relief valve (supplied with the unit), water pressure gauge, manual vent valve, and drainage valve.

Depending on the configuration they can then be equipped with a pumping unit (single or double pump managed in OR logic, standard or with inverter), buffer tank, expansion tank. A gate valve is also available as standard for cutting off pump suction, so that the pump can be replaced without needing to empty the unit's entire tank.

» Victaulic connection

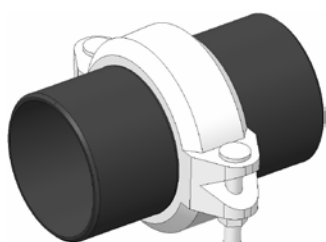

8.1.1 General guidelines for plumbing connections

When you are getting ready to set up the water circuit for the evaporator you should follow the directions below and in any case make sure you comply with national or local regulations (use the diagrams included in this manual as your reference).

1. Connect the pipes to the chiller using flexible couplings to prevent the transmission of vibrations and to compensate for thermal expansions. These units are all configured for installation of the water inlet-outlet pipes outside the unit (on the rear) and these pipes are supplied as standard accessories at no extra cost for the customer.
2. Install the following components on the piping:
 - Pair of quick-connection couplings with pipe section to be welded (optional item that may be selected from the price list). They facilitate the connecting operations to the plumbing system, greatly speeding up installation
 - temperature and pressure indicators for routine maintenance and monitoring of the unit. Pressure control on the water side allows to assess the correct functioning of the expansion tank and to detect water leakage in advance.
 - sumps on inlet and outlet piping for temperature detection, for a direct view of operating temperatures. They can also be consulted on the microprocessor on board the unit.
 - cut-off valves (gate valves) to isolate the unit from the hydraulic circuit.
 - metal net filter compulsory (inlet piping) with mesh no larger than 1 mm, to protect the heat exchanger from slag or impurities inside the piping. If the machine is combined with process cycles, it is recommended to install a readily serviceable uncoupling exchanger to prevent possible operation blockages and/or breakage of the plate evaporator.
 - air vent valve placed on the higher parts of the hydraulic circuit to bleed the air. The internal pipes of the unit are fitted with small air vent valves for bleeding the unit itself: this operation should be conducted when the unit is disconnected

from the power supply - make sure that the circuit is completely full of water and check again to make sure there is no air before starting the pump for the first time.

- discharge cock and, where needed, drain tank in order to empty the system for maintenance or seasonal stops. Drainage valve is provided on the optional water buffer tank: this operation may only be carried out when the unit is disconnected from the power supply.
- water safety valve: supplied to install near unit inlet pipes.

⚠ WARNING Failure to use anti-freezing solutions may cause serious damage to the hydraulic/cooling circuit in general.

Requirements for the heat transfer fluid and maintenance of the system

In order to avoid problems of reliability and/or operation of the hydronic system, it is necessary to take into consideration the characteristics of the heat transfer fluid (water or mixtures of water and glycol) and the hydraulic circuit.

The use of an unsuitable fluid can cause sludge deposits, algae growth, scale build-up, or corrosion and in some cases even erosion.

⚠ IMPORTANT: Never cut off the pumping unit while the unit is turned on. This could cause irreparable damage to the pump and the unit.

The Manufacturer does not accept any responsibility for damage caused by the use of untreated water, water containing particles or debris in suspension, water that has been incorrectly treated or admixed, or salt water.

By way of example, some (non-exhaustive) advice is given below (contact a specialist and consult specific standards such as UNI 8065)

- Ammonium ions (NH₄⁺) dissolved in water should be eliminated due to their high reactivity with copper.
- Chlorine ions (Cl⁻) pose a risk of holes developing due to corrosion.
- Sulfate ions (SO₄⁻⁻) must be eliminated because they may present a risk of corrosion.
- Limit for fluoride ions: 0.1 mg/l.
- Silicon may pose a risk of corrosion. Limit: < 1 mg/l.
- Electrical conductivity: the higher the specific resistivity, the lower the tendency of corrosion. Therefore, the following limit must be observed: Electrical conductivity: < 3,500 μS/cm
- pH: neutral pH at 20 °C (7 < pH < 8)
- Fixed residue (at 180 °C): < 2 000 mg/kg
- Conditioners Present within the concentrations prescribed by the supplier

The water must be analysed: it is advisable to contact a qualified water treatment specialist to determine the most suitable type of treatment according to the materials used in the hydraulic system.

The installed hydraulic circuit must include all the necessary devices for water treatment: mesh filter (immediately at the inlet to the unit), additive dosing systems if necessary, any intermediate heat exchangers, vent valves at all points of possible air accumulation, air intakes, isolation valves, etc., and anything else necessary according to best practice.

⚠ CAUTION: in case of regular shut-down, if it is necessary to empty the hydraulic circuit, the system must be flushed internally with nitrogen, making sure to leave it pressurized (at a pressure approximately equal to half the maximum

pressure of the hydraulic circuit) in order to avoid the entry of oxygen and to protect the parts of the system from the risk of corrosion.

8.1.2 Recommended water circuit

⚠ WARNING when making the plumbing connections, make sure there are no open flames in proximity to or inside the unit.

When setting up the water circuit, it is advisable to equip it with:

- valves for regulating (VI) the unit on the water pipes, immediately upstream and downstream from the unit itself, to be used in the event maintenance work is required;
- standard mechanical filter (FM) (OBLIGATORY!) on the pipe feeding the unit, in proximity to the latter;
- a mechanical filter (FM) (MANDATORY!) and a check valve (VNR), on the supply line upstream from the filling tap that is inside the unit;
- an air vent valve at the highest point of the circuit;
- water safety valve: supplied to install near unit inlet pipes.
- escape pipe for the safety valve (VS), which, in the event the safety valve opens, diverts the jet of water to an area where it cannot harm persons or things, (**Important!**);
- vibration-damping couplings (GA) on the pipes to prevent vibrations from being transmitted toward the system.

Important! It is advisable to ensure that the pipes connected upstream and downstream from the unit are not smaller in diameter than the plumbing connections of the unit itself.

Important! During wintertime the water circuit (or the water

chiller only) must be emptied to prevent damage caused by freezing; alternatively, the circuit may be filled with a mixture of water and glycol; the percentage of glycol necessary will depend on the lowest forecast temperature (see table):

Percentage by weight of ethylene glycol (%)	Mixture freezing temperature (°C)
0	0
10	-3
20	-8
30	-15
40	-25

NOTE: The percentage shown in the upper table are indicative. Always refer to your glycol supplier for the right freezing temperatures.

NOTE: For choice of glycol percentage to use, in case of low temperature water produced, is recommended keeping a edge of 5K on outlet water temperature in order to consider any temperature fluctuations inside the heat exchanger. Example: water temperature produced: -10°C, minimum water temperature during the fluctuations: -10-5=-15°C, recommended ethylene glycol percentage: >30%.

Important! If different antifreeze product is to be used, please contact the manufacturer.

Failure to install filters and vibration dampers may cause problems of clogging, breakages and noise, for which the manufacturer may not be held liable.

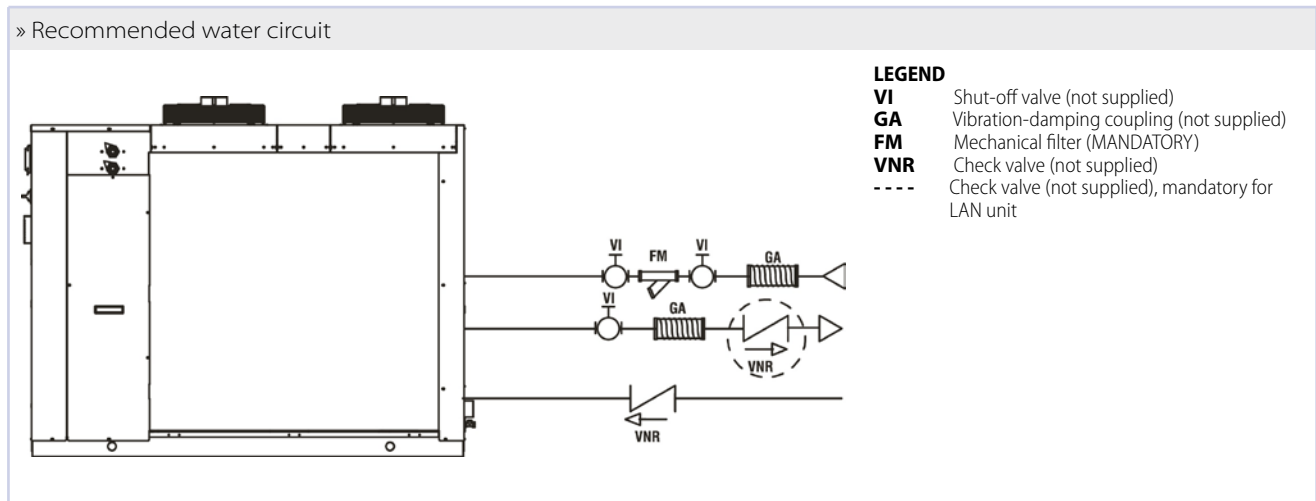

8.1.3 Filling the system

- Before you start filling, make sure that the system draining tap is closed.
- Open all the air vent valves of the system and of the indoor units and chiller.
- Open the system regulating devices.
- To fill the circuit open slowly the water tap of the system (optional).
- When water starts coming out of the air vent valves of the indoor units, close them and continue filling until the pressure gauge reading is 1.5 bars.

8.2 ELECTRICAL CONNECTIONS

All operations must be performed by qualified service personnel in accordance with current laws and regulations. For any

electrical work on the unit, refer to the electric diagrams supplied with the unit. It is recommended to make sure that:

- The characteristics of the mains power supply are adequate for the electrical inputs specified in the table of electrical data.

⚠ WARNING Before carrying out any job on electrical parts, make sure the power supply is disconnected. Check that the mains electricity supply is compatible with the specifications (voltage, number of phases, frequency) shown on the unit rating plate. The supply voltage may not undergo fluctuations exceeding $\pm 5\%$ of the rated voltage. The electrical connections must be made in accordance with the wiring diagram provided with the unit and the regulations in force.

⚠ WARNING Never attempt to modify internal electrical connections: any undue modifications will immediately invalidate the warranty.

An all-pole circuit breaker must be used on the electric panel upstream, conform to IEC Standards (contacts must be open at least of 3 mm), with suitable interruption capacity and differential protection, according to the electrical data tables in 8.3 p. 26 paragraph, described below, and installed as close as possible to the device.

For the unit power supply line use H07RN-F-type flexible rubber cables with the cross-section shown in the tables included in section 8.3 Electrical data. Use cable ducts and conduits suitable for outdoor installation to route the cables. Provide a switch and delayed fuses meeting the specifications given in the tables included in section 8.3 Electrical data. To access the electric control board it is necessary insert the power cable into the unit through the appropriate cable gland (figure p. 25).

Tighten the wires securely to the terminals and clamp the cable in place with the cable holder (figure p. 25).

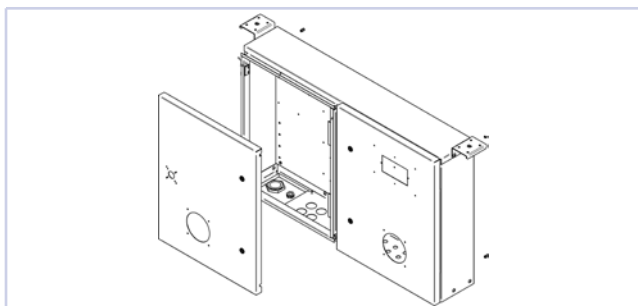

An earth connection is mandatory: connect the earthing wire to the terminal provided on the electric control board (see the electric control board layout supplied with the unit), marked \perp .

If you wish to include:

- a remote on/off switch
- a remote switch for changing over between the cooling and heating mode (PLI H only),
- a remote alarm indicator

It is a good idea to do so at this stage of the installation procedure, by connecting the switches or PCDS remote control (accessory) to the electric control board terminals as directed in section 8.3 Electrical data and using the unit wiring diagram as your reference.

All the PLI series units are equipped with a control panel designed to receive 24V external emergency power. Switching to an external power supply is done via an exchange relay when the unit is de-energised.

The wiring to the external power supply, which is the installer's responsibility, ensures that the refrigeration sensor control unit is always powered, in order to guarantee its operation even when the unit is switched off. In this manner it is always possible to check whether or not there is a gas leak.

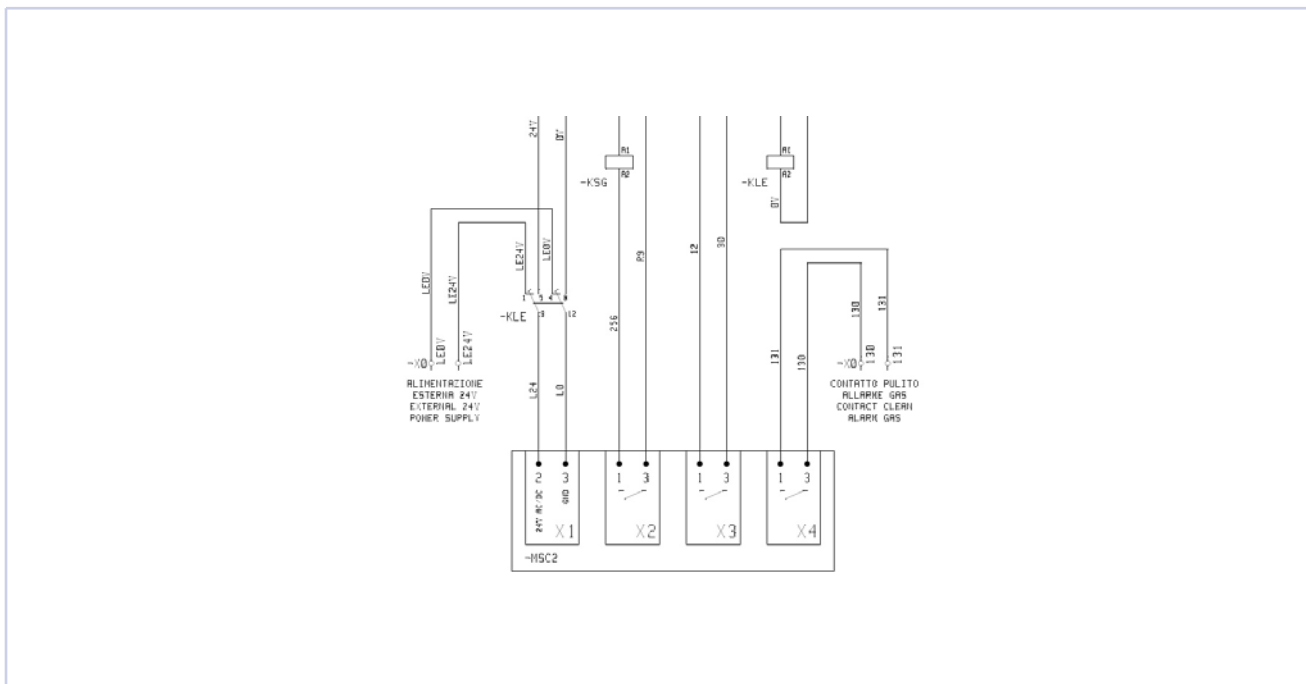

In addition to the external power supply, a voltage-free contact is available at the output of the control unit, which can be used by the customer to signal the alarm status of the unit (by means of, for example, an indicator light) or to operate emergency disconnections of the entire power supply line.

8.3 ELECTRICAL DATA

» Electrical data PLI

PLI			035	040	045	050
Maximum power input		kW	17,9	19,3	22,8	23,8
Maximum current absorption		A	44,0	46,0	49,0	50,0
Start up current		A	60	60	60	60
Startup current with soft starter		A	49	49	49	49
Auxiliary power supply		V-ph-Hz	230 - 1 - 50			
External power supply sensor			24VAC			
Cross-section area of power cables	(1)	mm ²	16,0	16,0	16,0	16,0
Safety fuse F		A	50	50	63	63
Circuit breaker IL		A	63	63	63	63

(1) The shown section is to be considered as the minimum recommended section. The cables must be chosen in compliance with CEI - UNEL 35024/1. standard.

- The maximum input power is the mains power that must be available in order for the unit to work.
- The maximum current absorption refers to the current that will trigger the internal safety devices of the unit. It is the maximum current allowed in the unit. This value may never be exceeded; it must be used as a reference for determining the size of the power supply line and the related safety devices (refer to the wiring diagram supplied with the units).

» Main electrical connection of units

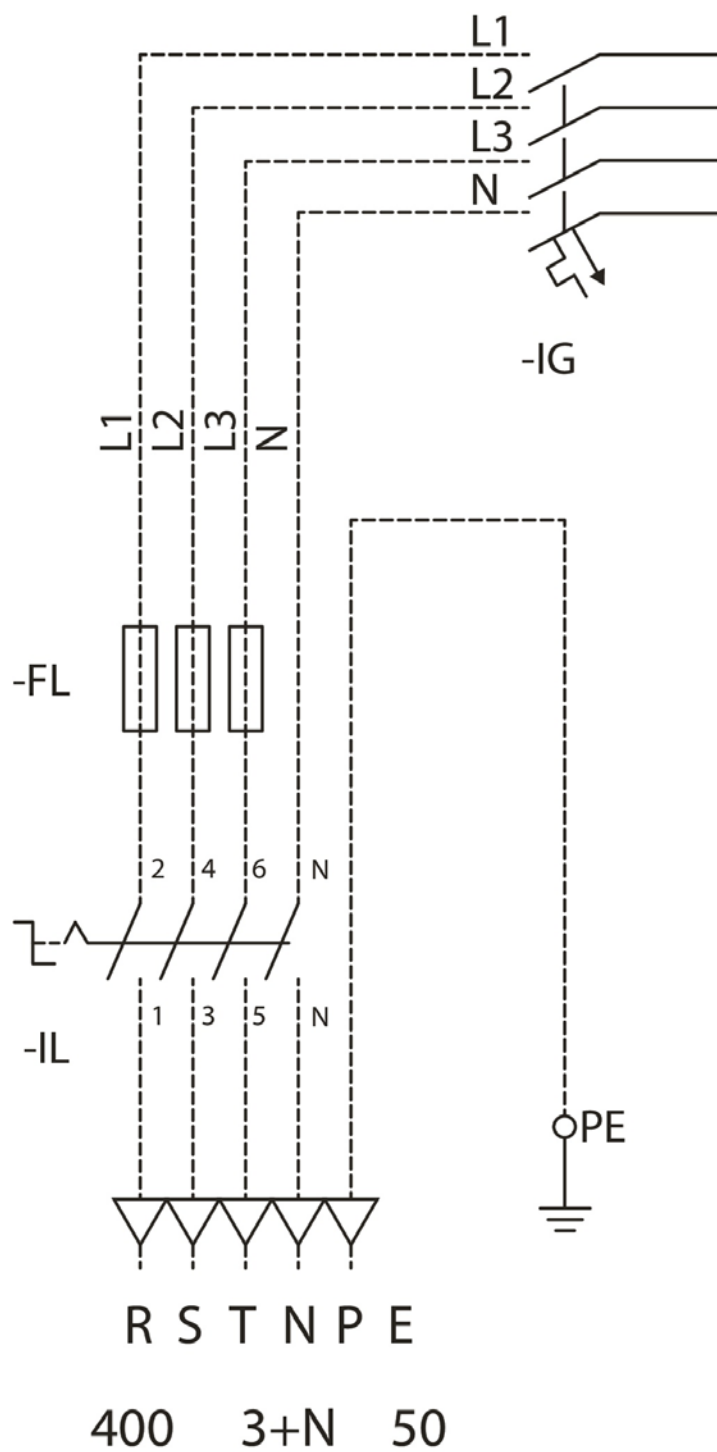

8.4 WATER CIRCUIT

» PLI (evaporator)

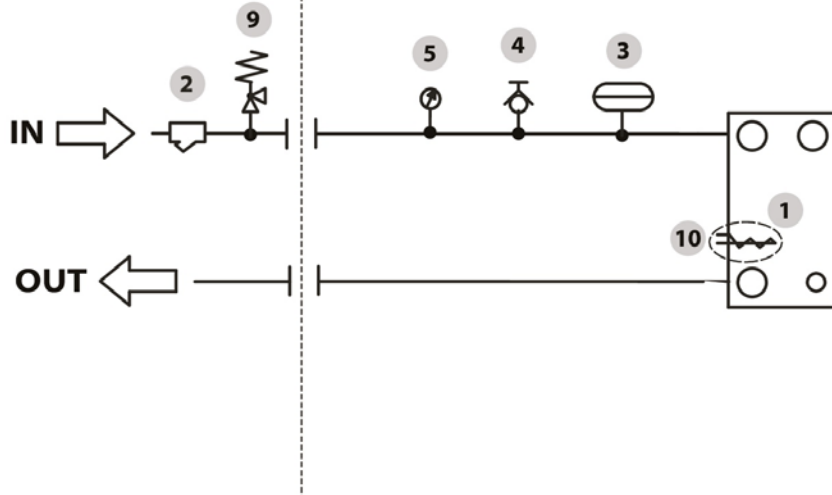

LEGEND

- 1 Evaporator
- 2 Water filter (included)
- 3 Flow switch
- 4 Air purge valve
- 5 Pressure gauge
- 6 -

- 7 -
- 8 -
- 9 Safety valve (supplied)
- 10 Antifreeze electric heating
- Internal and external borderline
- OPTIONAL

» PLI (evaporator and tank)

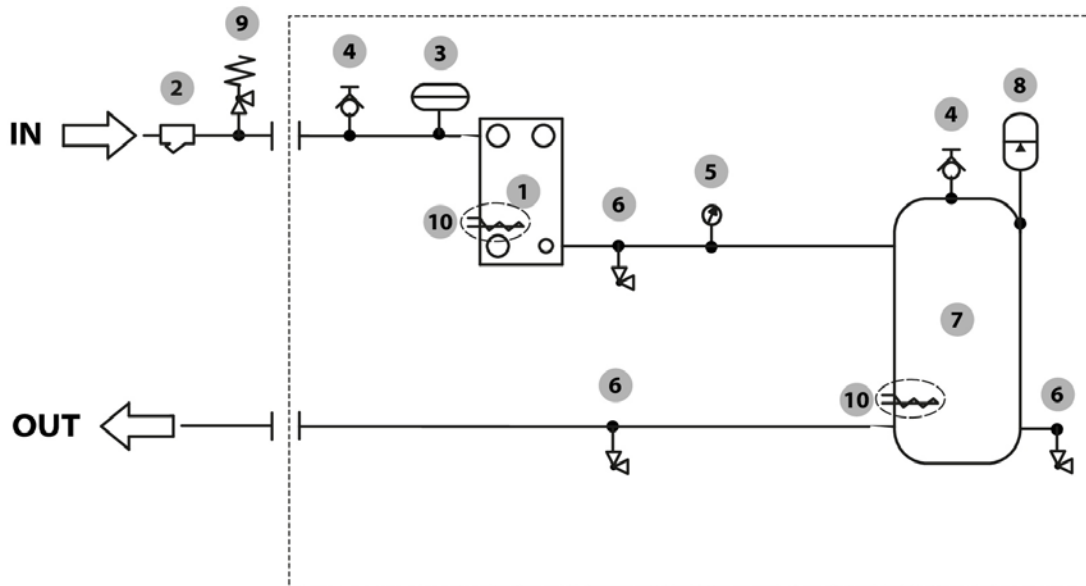

LEGEND

- 1 Evaporator
- 2 Water filter (included)
- 3 Flow switch
- 4 Air purge valve
- 5 Pressure gauge
- 6 Drain

- 7 Buffer tank
- 8 Expansion tank
- 9 Safety valve
- 10 Antifreeze electric heating
- Internal and external borderline
- OPTIONAL

» PLI (evaporator, pump and tank)

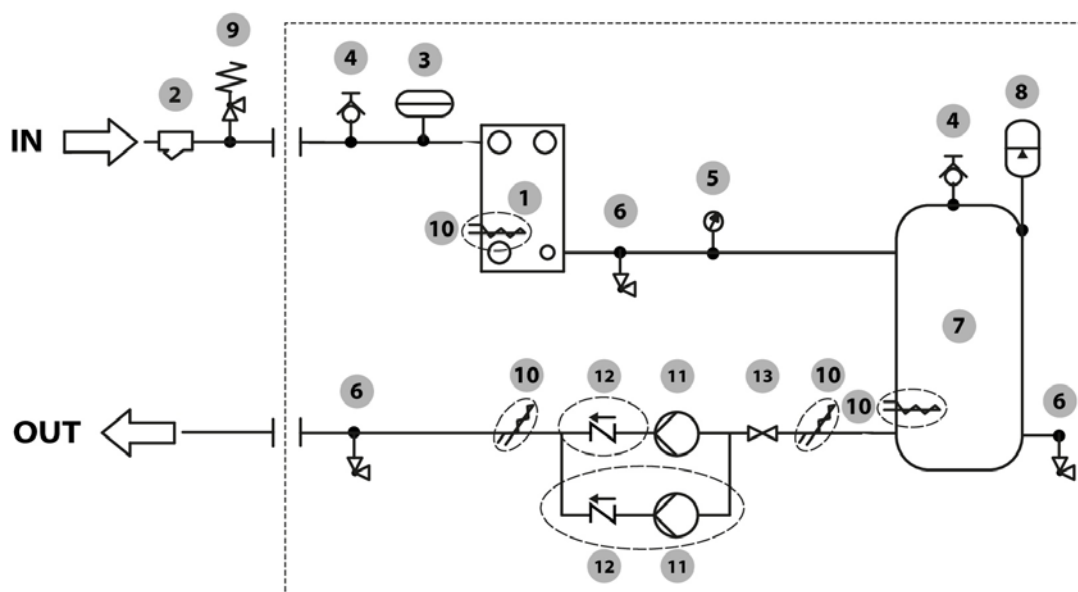

LEGEND

- | | | | |
|---|-------------------------|----|--|
| 1 | Evaporator | 8 | Expansion tank |
| 2 | Water filter (included) | 9 | Safety valve (supplied) |
| 3 | Flow switch | 10 | Antifreeze electric heating |
| 4 | Air purge valve | 11 | Hydraulic pump |
| 5 | Pressure gauge | 12 | Clapet valve |
| 6 | Drain | | ----- Internal and external borderline |
| 7 | Buffer tank | | --- -- OPTIONAL |

» PLI (evaporator and pump)

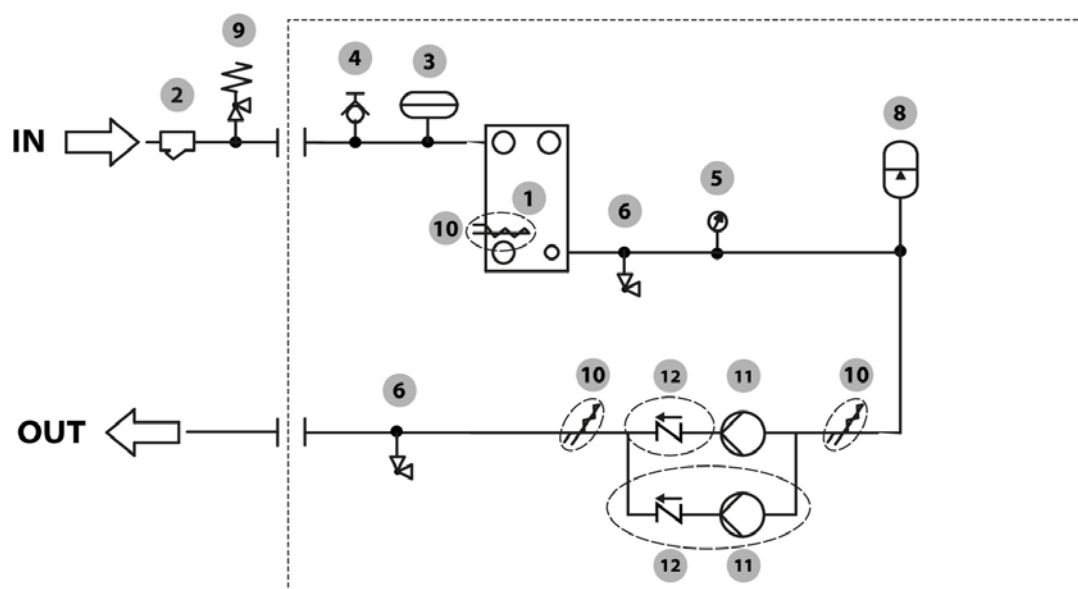

LEGEND

- | | | | |
|---|-------------------------|----|--|
| 1 | Evaporator | 8 | Expansion tank |
| 2 | Water filter (included) | 9 | Safety valve (supplied) |
| 3 | Flow switch | 10 | Antifreeze electric heating |
| 4 | Air purge valve | 11 | Hydraulic pump |
| 5 | Pressure gauge | 12 | Clapet valve |
| 6 | Drain | | ----- Internal and external borderline |
| 7 | - | | --- -- OPTIONAL |

» PLI (evaporator, tank and 2 pumps)

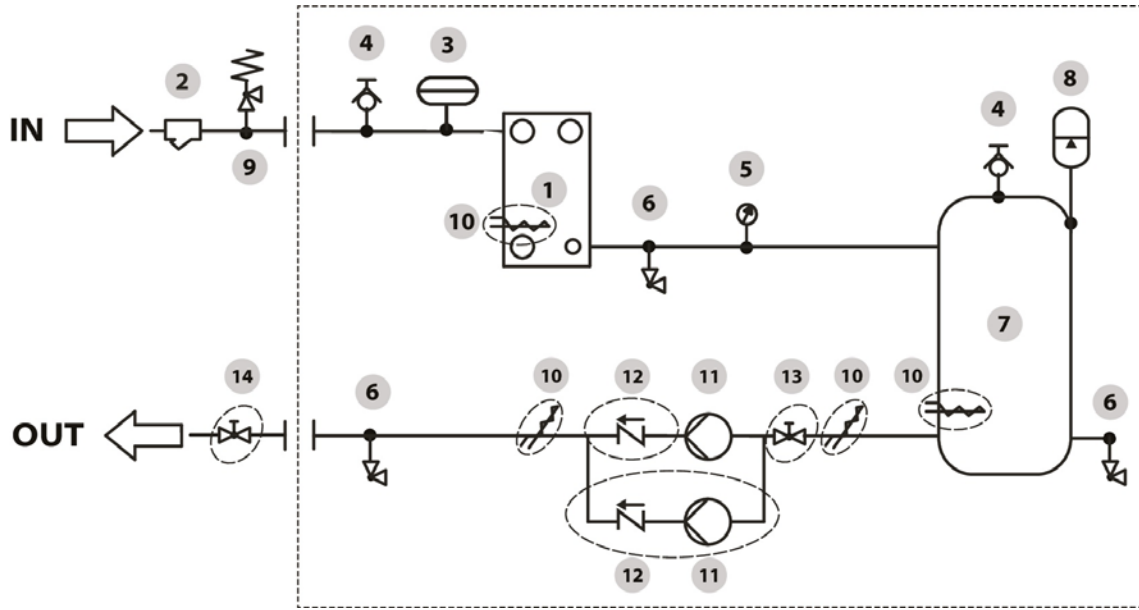

LEGEND

- 1 Evaporator
- 2 Water filter (included)
- 3 Flow switch
- 4 Air purge valve
- 5 Pressure gauge
- 6 Drain
- 7 Buffer tank
- 8 Expansion tank

- 9 Safety valve (supplied)
 - 10 Antifreeze electric heating
 - 11 Hydraulic pump
 - 12 Clapet valve
 - 13 Intake pump shut-off valve
 - 14 Outlet pumps shut-off valve (**NOT SUPPLIED**)
- Internal and external borderline
 - - - - - OPTIONAL

9 OPERATING LIMITS

The graphs below illustrate the operating limits of PLI units (in the case of continuous operation) in relation to the outlet water temperature and outdoor air temperature. The following limits are to be considered valid for water temperature fluctuations of 5 K.

⚠ WARNING: contact the support area if you wish to operate with water temperature fluctuations other than 5 K at full load.

⚠ IMPORTANT: except for special requests, which can be managed on request, the PLI series units set the number of compressors running according to the temperature of the water entering the unit (temperature returning from the system) and not according to the outlet temperature. Therefore, the settable set point always refers to the temperature of the water entering the unit. The outlet water temperature,

to which the following operating limits refer, therefore depends on the set point/differential combination set on the return line, on the design thermal differential, and on any unit splitting conditions (refer to the controller's technical manual). Therefore, if you would like to operate continuously in the vicinity of the operating range, you should always make sure that the temperatures are in compliance with the operating limits, even under conditions of load regulation and splitting of the unit. If in doubt, contact the Galletti product support department.

⚠ WARNING The units are designed to work with water and air temperatures falling within the range defined by the operating limits. Attempting to operate the units beyond these limits could cause irreparable damage to the units themselves.

9.1 OPERATING LIMITS PLI C

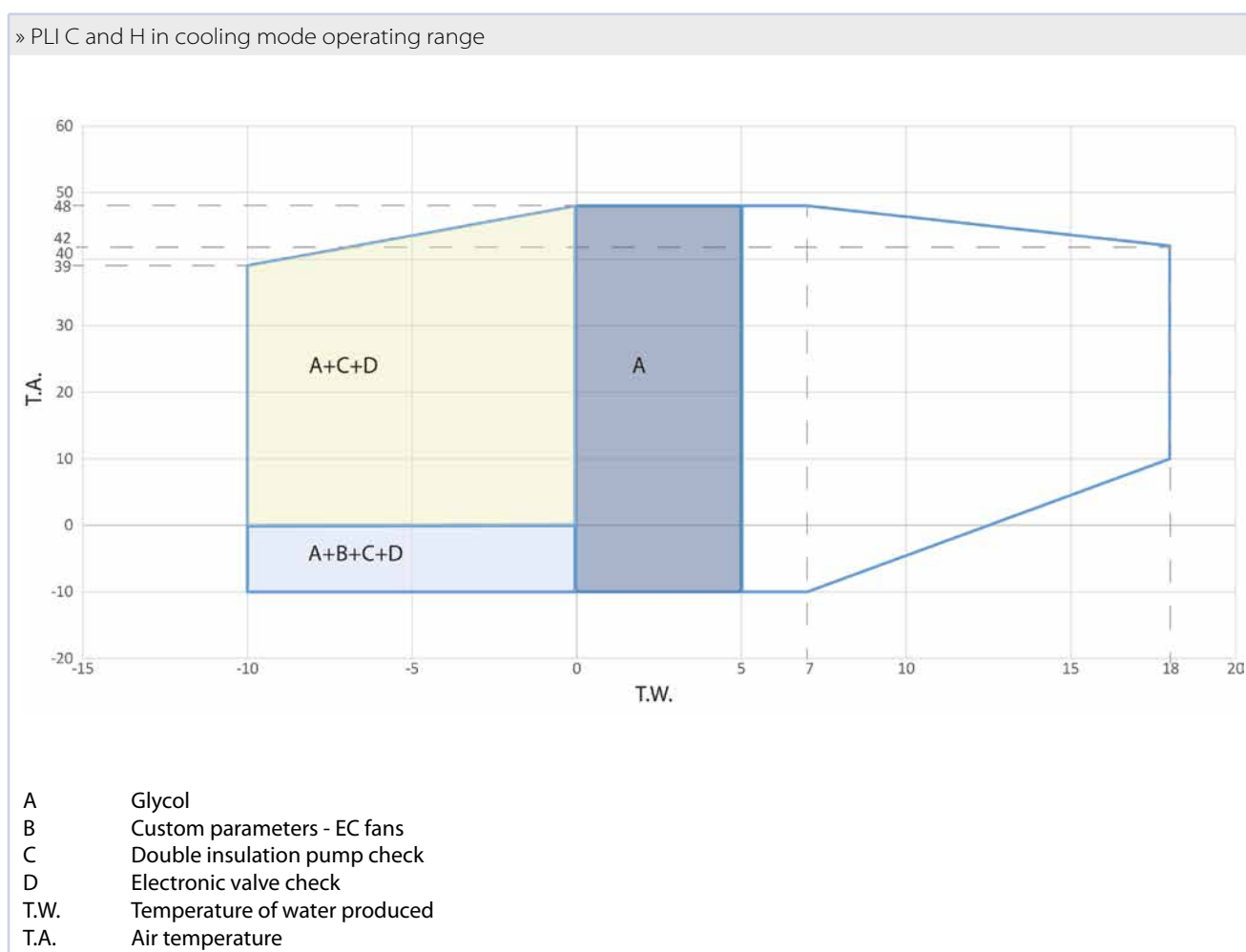

9.2 OPERATING LIMITS PLI H

» PLI H 35-40 operating range

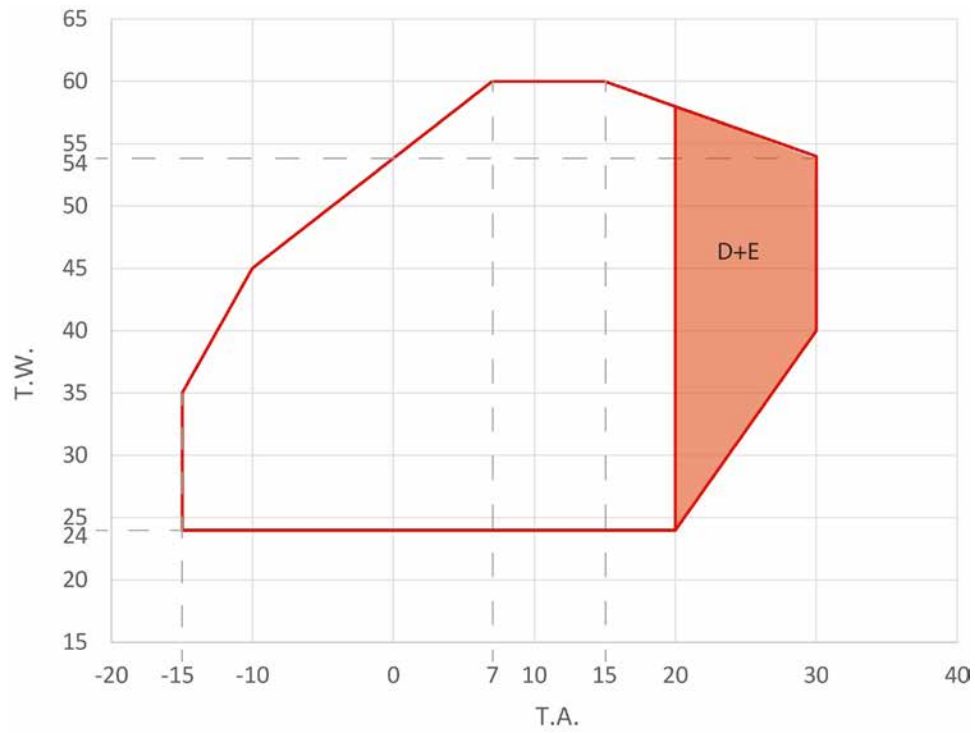

- D Electronic valve check
- E Evaporation control custom parameters
- T.W. Temperature of water produced
- T.A. Air temperature

» PLI H 45-50 operating range

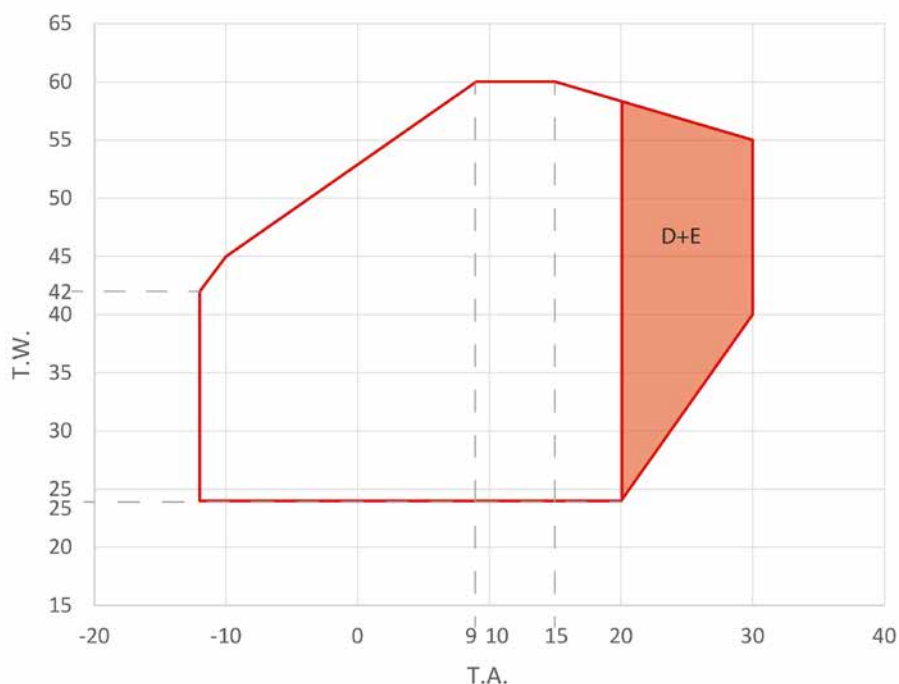

- D Electronic valve check
- E Evaporation control custom parameters
- T.W. Temperature of water produced
- T.A. Air temperature

9.3 THERMAL CARRYING FLUID

The hydraulic pumps belonging to the PLI series can operate with mixtures of water and ethylene glycol, with percentage indicated in the following table. On request it is possible to configure the units with pumping units fitted with special silicon carbide / silicon carbide-Viton seals. In these cases both ethylene glycol and propylene glycol can be tolerated at concentrations

of up to 35%.

⚠ IMPORTANT: observe the minimum water temperature indicated in the operating ranges.

⚠ IMPORTANT: Never go below the water flow rates indicated in the following table so as to prevent the unit from stopping due to a flow alarm.

» Minimum and maximum water flow admitted

PLI		035	040	045	050
Water flow MIN	l/h	2500(*)	3000(*)	3500	3500
Water flow MAX	l/h	8500	9500(**)	10500(**)	11000(**)
Maximum percentage of ethylene glycol	%	25	25	25	25

(*) In case of unit with pump on board configuration, reachable limit only with inverter pump (**) In case of unit with pump on board configuration, reachable limit only with HP pump

10 CONTROL AND SAFETY DEVICES

All the control and safety devices are set and tested in the factory before the unit is dispatched.

10.1 CONTROL DEVICES

10.1.1 Service thermostat

The service thermostat activates and deactivates the compressor according to the demand for chilled water (cooling mode) or heated water (heat pump mode), as determined by a sensor installed on the water exchanger inlet. This device is governed by the microprocessor control (see also the chapter regarding the microprocessor).

10.1.2 Control device settings

CONTROL DEVICES	SET POINT	MIN	MAX	DIFFERENTIAL
Service thermostat (outlet water temp. cooling mode)	11,5 °C	8 °C	20 °C	2 °C
Service thermostat (outlet water temp. heat pump mode)	40 °C	25 °C	47 °C	3 °C

10.2 SAFETY DEVICES

10.2.1 Gas leak detection unit

The units of the PLI range are equipped with a safety control unit with high sensitivity sensors for detecting refrigerant leaks. The sensors are located inside of the unit near the cooling circuit.

The electrical control board is kept at positive pressure by means of a ventilation system.

The safety control unit employs an active protection system, which acts on two levels:

- 1st level (non-serious alarm): when the concentration detected by one of the sensors reaches 1% of the lower flammability level, an alarm signal will be shown on the display. The unit will continue to operate.
- 2nd level (serious alarm): when the concentration detected by one of the sensors reaches 5% of the lower flammability level, the control unit will disable all the unit's power components. In this case the control unit sends back an external alarm signal that can be picked up by the voltage-free contact at terminals 130 and 131. By means of this alarm, the unit's power supply line can be completely disconnected by the customer. At this point the sensor board's power supply is guaranteed if and only if the control unit's external emergency power supply line is used as indicated in the "Electrical connections" section.

 **NOTE:** the unit's electrical control board has a connection for a dedicated 24V emergency power supply line. If this emergency power supply line is brought to the electrical control board (independent from the main switch upstream from the three-phase line), the safety control unit can remain active even in case of a leak (and consequent disconnection of the 3F line for serious alarm). In this way the personnel who carry out the repair are always warned of the dangerous situation (and also of the end of the danger, if the leak has been repaired and the dilution has been implemented)

 **IMPORTANT:** when the unit is switched off or disconnected, without the external power supply it is not possible to detect whether or not there is a gas leak. Therefore, it is not possible

to operate safely, especially during maintenance work. The choice not to use the external power supply is a risk that is borne by the customer. Galletti therefore, no liability shall be accepted for injury to persons or damage to property resulting from the incorrect use, or non-use, of the external power supply auxiliary contacts.

10.2.2 High pressure switch

The high pressure switch stops the compressor when the delivery pressure exceeds the set value.

10.2.3 Low pressure switch

The low pressure switch stops the compressor when the intake pressure falls below the set value.

10.2.4 Anti-recycle timer

The function of the timer is to prevent excessively frequent compressor starts and stops. This device is a function included in the microprocessor control; it prevents the compressor from starting up again after a stop until a set period of time has elapsed (approximately 5 minutes).

10.2.5 Antifreeze thermostat

The antifreeze thermostat situated at the evaporator outlet performs a dual function: it prevents ice from forming in the evaporator in the event of an excessive decrease in the water flow; it stops the unit in the event of a failure of the service thermostat. This device is governed by the microprocessor control (see also the chapter regarding the microprocessor).

10.2.6 Water differential pressure switch

The water differential pressure switch stops the unit in the event of an excessive reduction in the water flow, thus protecting it from the formation of ice (chiller operation) and excessively high condensation temperatures (heat pump operation)

10.2.7 Water safety valve

The water safety valve opens when the pressure within the water circuit reaches a level that may cause damage to the unit. This accessory is supplied and the installation is on responsibility of the installer.

10.2.8 Safety device settings

Safety device	Start up	Differential	Resetting
Maximum pressure switch (bars)	42	-	Manual
Minimum pressure switch (bars)	1,5	-	Automatic
Antifreeze thermostat (°C)	3	3	Manual
Water safety valve (bars)	4	-	-

11 ROUTINE MAINTENANCE AND CHECKS

It is recommended to carry out periodic checks of the safety devices (pressure switches and safety valves) and verify the absence of refrigerant leaks.

⚠ IMPORTANT: After the first start-up, the periodic checks must be carried out in conformity with the schedule and the manners provided for by current national regulations.

To keep the unit in good working order and guarantee the expected levels of performance and safety, it is necessary to carry out some periodic routine checks: some may be performed directly by the user while others must be carried out solely by specialised personnel.

11.1 CHECKS TO BE PERFORMED BY THE USER

The checks and operations described in this section may be easily performed by the user, provided that the latter shows a minimum of attention.

— Remove any dirt that has built up around the coil or objects trapped in the mesh protecting the coil itself (leaves, paper etc., to be carried out monthly).

⚠ WARNING: Be especially careful when working in proximity to finned coils since the aluminium fins are extremely sharp and can cause cuts.

— Check the level of water in the circuit using the water pressure gauge, which should indicate a pressure of about 1.5 bars (monthly).

— Check that the escape pipe of the water safety valve is tightly secured.

— Check the water circuit for leaks (monthly).

— If the unit is to remain out of service for a long time, drain the water (or other fluid present in the circuit) from the pipes and the unit itself. This is indispensable if during the period of quiescence the ambient temperature is expected to fall below the freezing point of the fluid used (seasonal operation). Drain the unit and parts of the circuit subject to the risk of freezing by opening the RS (optional) emptying tap.

— Before placing the unit back in service at the start of the season, refill the water circuit as directed in section 1.5 p. 7.

— Check that the noise emissions of the unit are regular (monthly).

— If necessary, release the pump rotor.

11.1.1 Microchannels air condenser maintenance

For PLI C units, proper cleaning and periodic maintenance of the microchannel heat exchanger is essential in order to maintain its aerulic performance.

⚠ IMPORTANT: a dirty microchannel heat exchanger negatively affects the performance of the unit by increasing the condensation temperature. As a result, there is a drop in the unit's energy efficiency and, in the most serious cases, the unit's safety devices are activated in order to prevent irreversible damage.

There are significant differences between the microchannel heat exchanger and the conventional finned block heat exchanger: one of which is that the microchannel coil tends to accumulate more dirt on the surface than inside, which makes it easier to clean.

The maintenance procedures listed below are recommended:

— Use a vacuum cleaner to remove surface dirt (preferably using a soft accessory). It is also possible to use compressed air, taking the utmost care to blow from the inside out

— Rinse with water by allowing it to flow through all the fins' openings. Pressurised water (max 60 bar, max 55 °C) can also be used, but the direction of the spray must be strictly perpendicular to the edge of the fins. The spray pattern must be flat. However, cleaning with pressurised water is not recommended since spraying in the wrong direction can destroy the microchannel heat exchanger, which is a significant risk factor.

⚠ IMPORTANT: do not use high-pH products for cleaning. Always use water with neutral pH.

— After the heat exchanger has been cleaned, it must be visually inspected for any traces of corrosion. If environmental corrosion factors cannot be eliminated, the heat exchanger must be requested with a surface treatment to protect it (e.g. epoxy paint or electrophoresis treatment)

The heat exchanger must be cleaned every three months or whenever it has not been operated for more than a week.

In the case of heat exchangers with an electrophoresis treatment, failure to clean them will void the warranty and could lead to a reduction in the life of the heat exchanger. In these cases it is necessary to use a detergent approved for cleaning and a product approved for removing chlorides and soluble salts.

⚠ IMPORTANT: do not use corrosive cleaning chemicals, bleach, or acid cleaners.

11.2 CHECKS AND MAINTENANCE TO BE PERFORMED BY SPECIALISED PERSONNEL

⚠ WARNING: Personnel working on units containing A2L refrigerant must have adequate and documented preparation and appropriate training in relation to the fire safety aspects of flammable fluids and their handling.

⚠ WARNING: Always use appropriate Personal Protective Equipment. The most common protective equipment is: helmets, protective goggles, goggles for braze welding, gloves, ear plugs, and safety shoes. Do not wear flammable clothing. Always perform a risk analysis of the installation site.

⚠ WARNING: ADOPT, IF AND WHEN NECESSARY, ADDITIONAL COLLECTIVE AND PERSONAL PROTECTION MEASURES.

All the operations described in this section MUST ALWAYS BE PERFORMED BY QUALIFIED PERSONNEL.

⚠ WARNING: Before carrying out any work on the unit or accessing internal parts, make sure you have disconnected it from the mains power supply.

⚠ WARNING: The upper part of the compressor casing and the outlet pipe reach high temperatures. Be especially careful when working in their vicinity.

⚠ WARNING: Be especially careful when working in proximity to the finned coils: the aluminium fins are extremely sharp and can cause cuts.

⚠ ATTENTION: In case of extraordinary weather events, the unit must be stopped; prior to putting it back into operation, it must be inspected by qualified personnel who must first check the integrity of the cooling circuit (pipes and components) and electrical connections, and verify that the safety devices are working properly.

After completing maintenance jobs, always replace the

panels enclosing the unit and secure them with the fastening screws provided.

The checks and operations described in this section must be carried out on a yearly basis by specialised personnel.

- Check the electric control board terminals to ensure that they are securely tightened: the movable and fixed contacts of the circuit breakers must be periodically cleaned and replaced whenever they show signs of deterioration.
- Check the compressor and pipes for oil leaks.
- Check the efficiency of the water differential pressure switch.
- Clean the metal filters mounted in the water pipes.
- Clean the finned coil by aiming a jet of compressed air in a direction opposite to the outflow of air, taking care not to bend the fins.

⚠ CAUTION: Installation and maintenance activities performed on heat pumps may only be carried out by personnel and companies holding the appropriate certificate in compliance with Regulation (EU) no. 2015/2067, which establishes, in accordance with Regulation (EU) no. 517/2014 of the European Parliament and of the Council, minimum requirements for companies and personnel with regard to stationary refrigeration equipment, air conditioning equipment, and heat pumps containing certain fluorinated greenhouse gases.

The refrigerant concentration sensors, which represent the sensitive components of the safety system, must be replaced once a year. The new sensors must be absolutely identical to the original ones **under penalty of voiding the warranty and CE marking of the unit.**

In order to buy the right sensors please refer to the following Galletti's codes:

RG11014920: Unit gas detection sensor

⚠ WARNING: During periodic controls it is suggested to check the right behaviour of the sensor control board so that there is no alarm. It must be scheduled also the replacement of sensors with the help of the temporal warning given by unit control software. The first warning regarding necessity of calibration or replacement will become also blocking once is reached the expiration date.

⚠ WARNING: in case of failure of one or more sensors, the LED of sensors control board lights up with a yellow light.

⚠ IMPORTANT: THE ON-BOARD CONTROL UNIT MUST NOT BE CONSIDERED A SUBSTITUTE FOR THE SAFETY AND DETECTION SYSTEM REQUIRED FOR THE INSTALLATION SITE, THE MACHINE ROOM, OR ANYTHING ELSE REQUIRED BY THE SYSTEM DESIGNER FOLLOWING THE NECESSARY RISK ASSESSMENT.

12 COOLING CIRCUITS

» Legend

N°	COMPONENT	SYMBOL
1	Compressor	
2	Evaporator	
3	Condenser	
4	Thermostatic valve	
5	Electrical fan	
6	Filter	
7	Sight glass	
8	Solenoid valve	
9	High pressure switch	
10	Low pressure switch	
11	High pressure gauge	
12	Low pressure gauge	
13	Service connection	
14	Differential pressure switch	
15	Check valve	
16	4 Way diversion valve	
17	Liquid separator	
18	Liquid receiver	
19	Pressure transducer	
20	Liquid distributor	
21	Oil pressure switch	
22	De-superheater	
23	Shut-Off valve	
24	Pocket	
25	Safety valve	
26	Fusible plug	
27	Flow switch	
28	Restrictor	
29	Electronic expansion valve	
30	Low pressure safety valve	
31	Differential pressure regulating valve	

» PLI F1 C cooling circuit

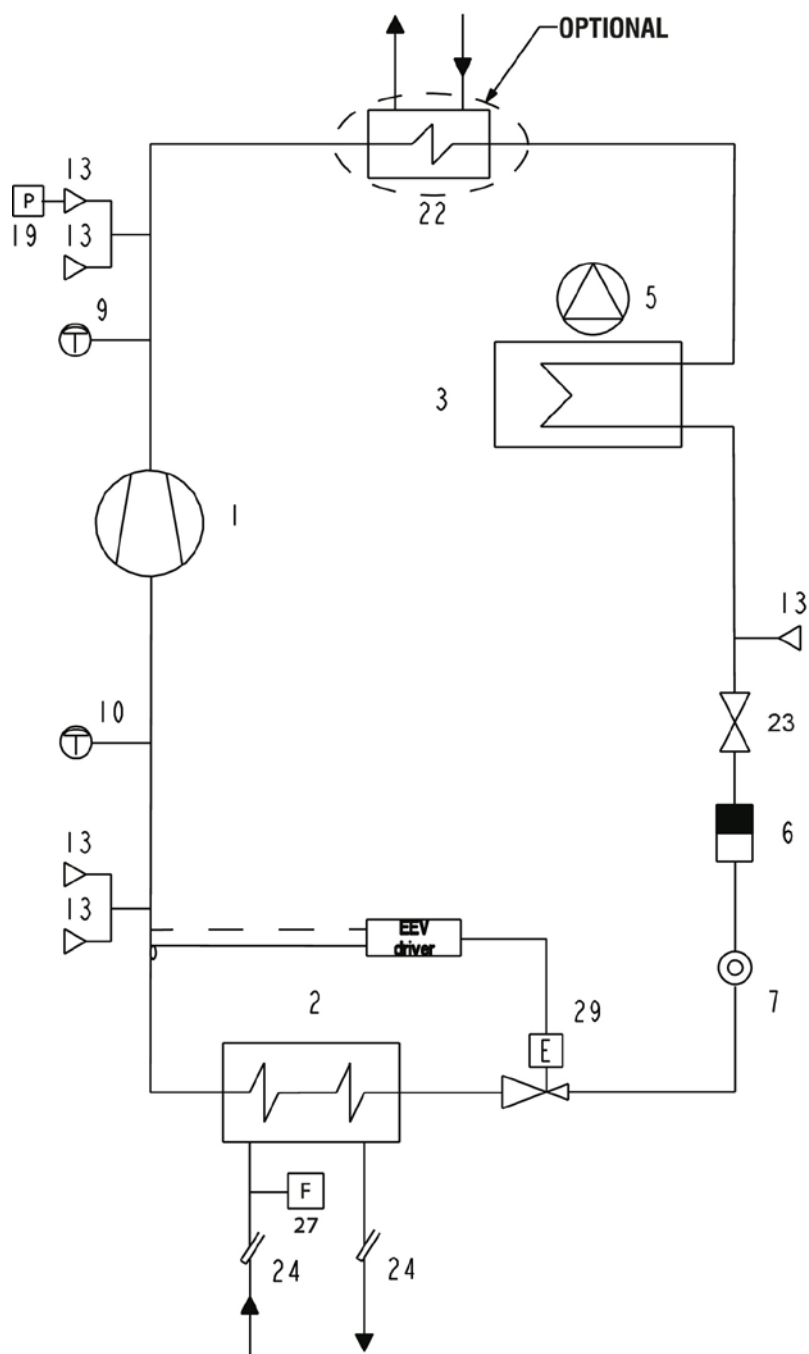

» PLI F2 C cooling circuit

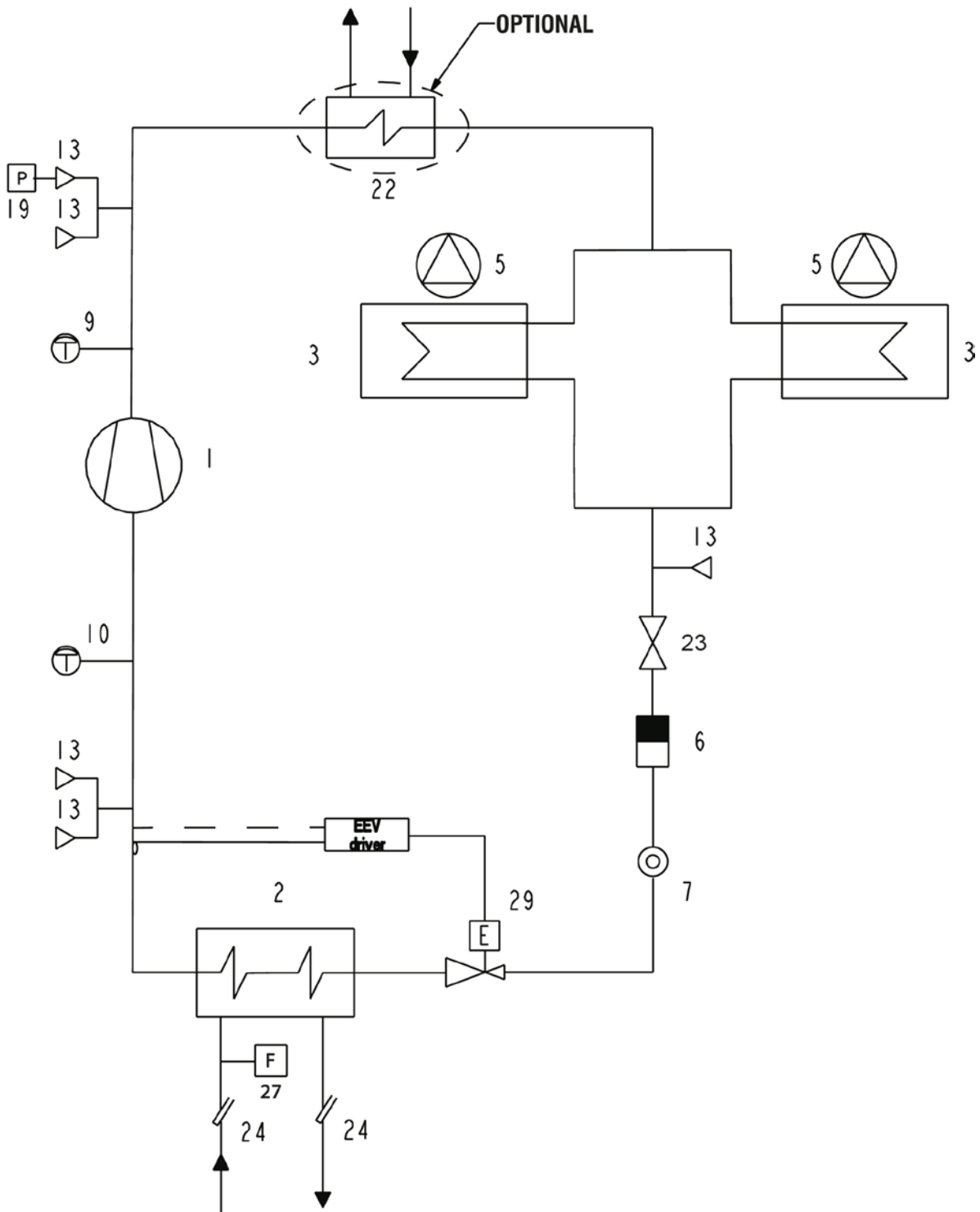

» PLI F1 H cooling circuit

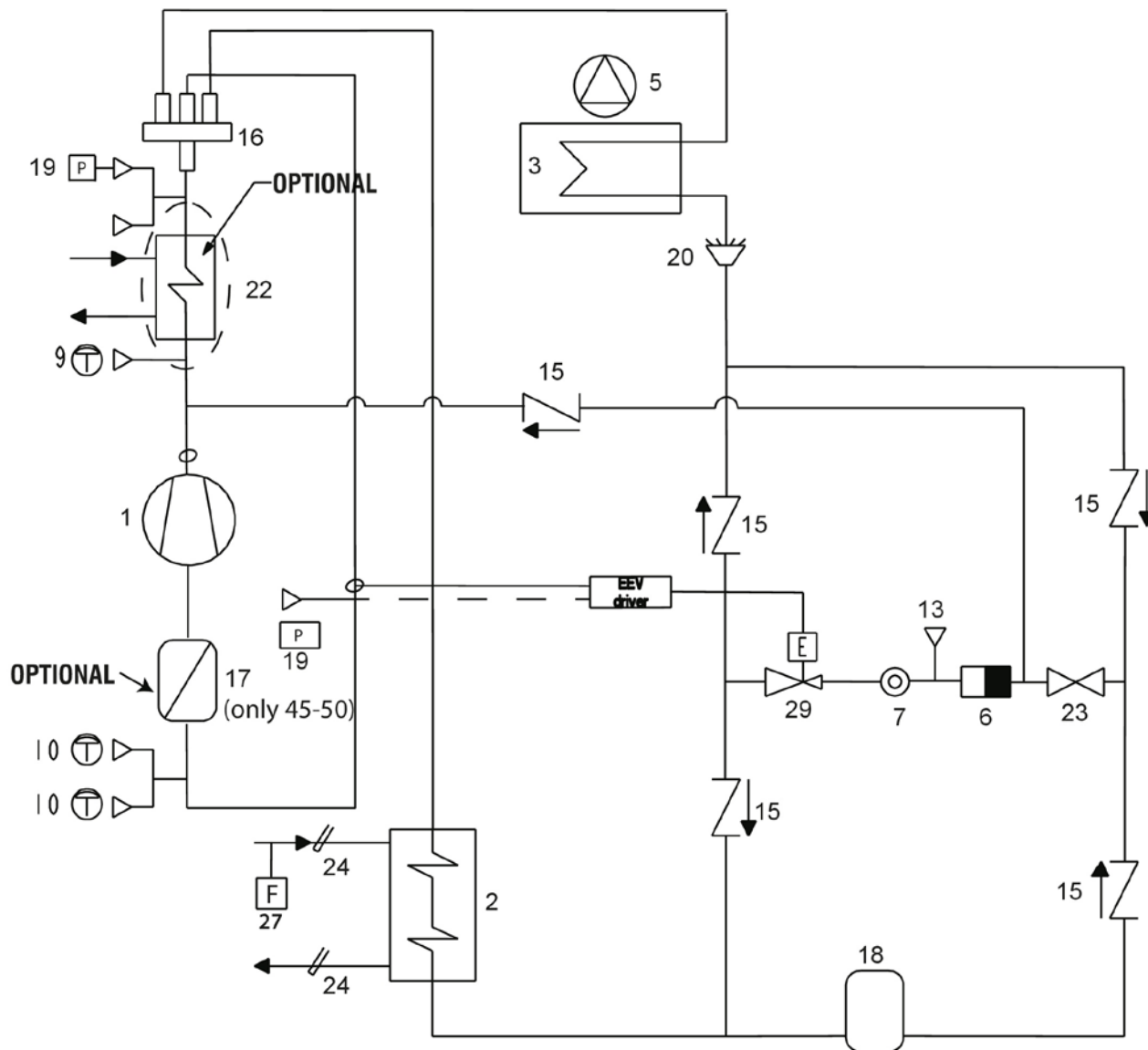

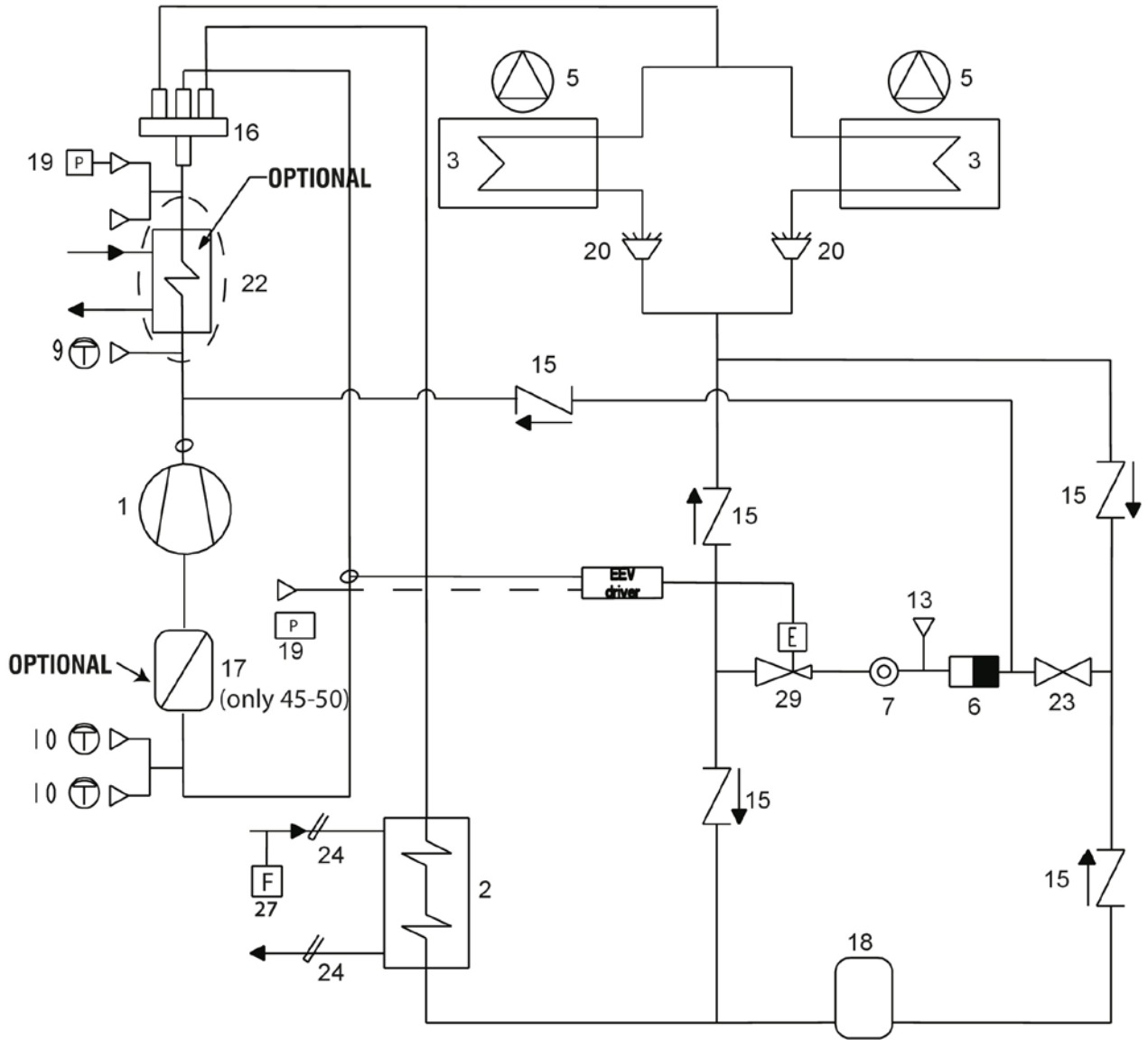

13 TROUBLESHOOTING

In this section you will find a list of the most common problems that may cause the chiller unit to stop or malfunction. Possible remedies are shown alongside a description of easily identifiable remedies.

⚠ WARNING Extreme care should be taken when performing work or repairs on the unit: overconfidence can result in injuries, even serious ones, to inexperienced individuals. Operations marked with the letter "U" can be performed directly by the user, who must carefully follow the instructions provided in this manual. Operations marked with the letter "S" may be performed exclusively by specialised personnel. Once the cause has been identified, you are advised to contact a Galletti S.p.A. service centre or a qualified technician for help.

SYMPTOM			Who can take corrective action U = User S = specialised personnel	Probable cause	Possible remedy
A The unit does not start	X	X	S	Faulty connection or contacts open. Wrong voltage	Check the voltage and close the contacts
	X	X	S	Not enabled by remote controls	Check the efficiency of the water circulation pump, pressure switch, bleed air from the circuit; check whether contacts 16 and 30 on the terminal board are closed
	X	X	U	Anti-recycle timer active	Wait 5 minutes until the timer enables operation
	X	X	S	Service thermostat sensor defective	Check and replace if necessary
	X	X	U	Not enabled by service thermostat	System at the set temperature, no demand; Check the setting
	X	X	U	Not enabled by antifreeze thermostat	Check the water temperature Check the antifreeze setting
	X	X	S	Antifreeze sensor defective	Check whether it is functioning properly
	X	X	S	Tripping of main circuit breaker	Check for the presence of short circuits in the wiring or windings of the pump, fan and compressor motors or in the transformer
	X	X	S	Not enabled by high or low pressure switch	See items D-E
	X	X	S	Compressor defective	See item B
	X	X	S	Refrigerant leak	See item Q
B The compressor does not start	X	X	S	Compressor burnout or seizure	Replace the compressor
	X	X	S	Compressor contactor deenergized	Check the voltage at either end of the compressor contactor coil and verify the continuity of the coil itself
	X	X	S	Power circuit open	Locate the cause that tripped the protection; check for the presence of short circuits in the wiring or windings of the pump, fan and compressor motors or in the transformer
	X	X	S	Power circuit open	The compressor has operated in critical conditions or there is insufficient refrigerant within the circuit: check the working conditions and make sure they fall within the operating limits. Refrigerant leak: refer to item G
C The compressor starts up and stops repeatedly	X	X	S	Minimum pressure switch has tripped	See item E
	X	X	S	Compressor contactor defective	Check and replace if necessary
	X	X	U	Wrong set-point or differential setting	Change them according to the indications given in the tables
	X	X	S	Lack of refrigerant	See item G
D The compressor does not start because the maximum pressure switch has tripped	X	X	S	Pressure switch failure	Check and replace
	X	X	S	Excessive refrigerant charge	Discharge the excess gas
	X		U	Finned coil obstructed, insufficient air flow	Remove dirt from the coil and any obstacles to air flow
	X	X	S	Fan not working	See item F
		X	U	Water circulation pump blocked	Release the pump
		X	S	Water circulation pump defective	Check the pump and replace it if necessary.
	X	X	S	Presence of incondensable gas in the cooling circuit	Recharge the circuit after having drained and evacuated it
X	X	S	Refrigerant filter clogged	Check and replace	

SYMPTOM	❄️	❄️	Who can take corrective action U = User S = specialised personnel	Probable cause	Possible remedy
E The compressor does not start because the minimum pressure switch has tripped	X	X	S	Pressure switch failure	Check and replace
	X	X	S	Unit completely empty	See item G
		X	U	Finned coil obstructed, insufficient air flow	Remove dirt from the coil
	X		S	Water circulation pump blocked	Release the pump
	X		S	Water circulation pump blocked defective	Check the pump and replace it if necessary.
		X	S	Presence of frost on the evaporating coil	See item O
		X	S	Evaporator fan not working	See item F
	X	X	S	Refrigerant filter clogged	Check and replace
	X	X	S	Expansion valve is not working properly	Check and replace if necessary
	X	X	S	Presence of humidity in the cooling circuit	Replace the filter and, if necessary, dry out the circuit and recharge
F The fans do not start	X	X	S	Fan contactor deenergized (C only)	Check the voltage at either end of the compressor contactor coil and verify the continuity of the coil itself
	X	X	S	No power output by the fan speed control card	Check and replace if necessary
	X	X	S	The fan's internal thermal protection has tripped	Check the fan conditions and the air temperature while the unit is running
	X	X	S	Fan motor defective	Check and replace if necessary
	X	X	S	Loose electrical connections	Check and fasten securely
G Lack of gas	X	X	S	Cooling circuit leak	Check the cooling circuit using a leak detector after pressurising the circuit to approximately 4 bars Repair, evacuate and refill
I Frost in liquid pipe downstream from a filter	X	X	S	Liquid filter clogged	Replace the filter
L The unit works continuously without ever stopping	X	X	S	Lack of refrigerant gas	See item G
	X	X	U	Wrong setting of operating thermostat	Check the setting
	X	X	S	Thermal overload	Reduce the thermal load
	X	X	S	Compressor does not provide the rated heating capacity	Check and replace or overhaul
	X	X	S	Liquid filter clogged	Replace
M The unit works regularly but with an insufficient capacity	X	X	S	Low level of refrigerant	See item G
	X	X	S	4-way cycle reversing valve defective	Check the valve power supply and coils and replace the valve if necessary
N Frost in the compressor intake pipe	X	X	S	Expansion valve is not working properly	Check and replace
	X		S	Water circulation pump blocked	Release the pump
	X	X	S	Water circulation pump defective	Check the pump and replace it if necessary.
	X	X	S	Low level of refrigerant	See item G
	X	X	S	Liquid filter clogged	Replace
O The defrosting cycle is never activated		X	S	4-way cycle reversing valve defective	Check the valve power supply and coil and replace the valve if necessary
		X	S	The defrost thermostat has broken down or has been set incorrectly	Check and replace if defective or change the setting
P Abnormal noises detected in the system	X	X	S	The compressor is noisy	Check and replace if necessary
	X	X	S	The panels vibrate	Fasten properly
Q The release A2L gas	X	X	S	Leak presence in refrigerant circuit	DO NOT enter the area until the sensors detect the presence of gas. Always request the assistance of specialised personnel for gas refilling.

14 RETIRING THE UNIT

When the unit has reached the end of its working life and needs to be removed and replaced, a series of operations should be carried out: In particular, the disposal of the unit should be carried out solely by qualified technicians specifically trained for this type of equipment, in conformity with current regulations.

Main components and materials:

- Plastic (ABS) and pre-painted or painted sheet metal
- Heat exchanger: copper and aluminium / steel
- Electric motors: copper, aluminium, iron
- Fans: plastic material (ABS) or aluminium/iron
- Internal structure: galvanized sheet (ferrous materials)
- Refrigerant piping: copper / brass
- Packaging: cardboard / polystyrene / wood
- Instructions: paper

The refrigerant gas and the compressor's lubricating oil must be recovered and sent to an authorized collection center.

In general, the structure and the components (if they can no longer be used) must be disassembled and separated according to the main type of material. Especially for the parts made of iron, copper, and aluminum, which are present in large quantities in the product.

If the unit contains electronic boards or controls of any kind, at the time of disposal of the unit, it is necessary to consider these components to be "electrical and electronic waste," and they must be disposed of in accordance with the requirements of Directive 2012/19/EU - (also known as the WEEE (Waste Electrical and Electronic Equipment) – Directive.

These products should be handled properly and the materials that they are made of – such as copper, iron, steel, aluminum, glass, silver, gold, lead, and mercury – should be sorted for recycling, thereby avoiding a waste of resources that can be reused to manufacture new equipment, thus contributing to environmental sustainability.

To learn the EWC (European Waste Catalog) code of the different types of materials listed above, refer to Decision 2014/955 /EU of the European Commission (and any subsequent amendments thereto).



Galletti S.p.A Organization has a Management System Certified by Kiwa Cermet Italia S.p.A, according to the UNI EN ISO 9001:2015, UNI EN ISO 14001:2015 and UNI ISO 45001:2018 standards.

via Romagnoli 12/a
40010 Bentivoglio (BO) - Italy
Ph. +39 051/8908111 - Fax +039 051/8908122

www.galletti.com