

Outdoor packaged unit

## MPE 4 - 76 kW



### PLUS

- » Completely configurable range
- » Dual-compressor version that guarantees high efficiency at partial loads
- » Production of chilled water up to an air temperature of 47 °C
- » Built-in hydronic unit
- » Available ducted version on request
- » -

### Efficiency under all operating conditions

MPE water chillers and heat pumps are designed for outdoor installation in both residential and industrial applications. The range uses R410A refrigerant, which assures high levels of performance with relatively low energy consumption and features 10 models in the chiller version and 29 models in the heat pump version, with cooling capacities ranging from 20 to 71 kW and heating capacities from 5 to 85 kW.

The finned block heat exchangers have been optimised for R410A and use 8 mm copper pipes, which permit a better heat exchange and quiet operation of the fans. Their generous sizing guarantees the production of chilled water even with outdoor air temperatures as high as 51°C.

In the MPET models, with a double compressor on the same cooling circuit, the working temperature range is extended further and efficiency at partial loads increases. In demanding working conditions the microprocessor controller activates the capacity control mode, doubling the condensing surface available to the single compressor.

The self-adaptive logic allows the setpoint to be adjusted automatically according to the outdoor temperature in order to reduce consumption and broaden the working temperature range.

The unit can also function in systems with a low water content, even without the use of a storage reservoir, thanks to the automatic adjustment which limits the number of compressor starts and thus extends the life of the compressors themselves.

The exclusive Smart Defrost System (optional feature available with the advanced controller) can correctly identify an impairment of performance in the outdoor exchanger due to the formation of ice and minimise the process time in relation to normal operation of the unit.

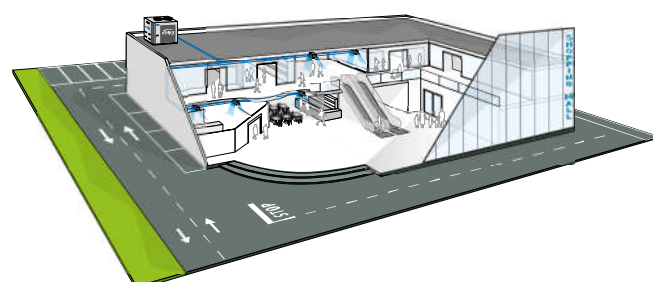

MPE heat pumps and water chillers are designed for heating or cooling the water to be used in air-conditioning systems for residential, commercial or industrial use.

## MAIN COMPONENTS

### Structure

Painted galvanised sheet steel structure (RAL9002) for an effective resistance to corrosive agents. Fastening devices are made of non-oxidizable carbon steel that has undergone surface-passivating treatments.

### Customised hydraulic kit

The structure can accommodate hydronic kits with pump, expansion tank, and buffer tank. High head pump made entirely of stainless steel, already configured for use with mixtures of water and ethylene glycol up to 35% and provided with internal thermal protection.

### Fan drive assembly

Electric fan with external rotor motor directly keyed to the axial fan, with internal thermal protection on the windings.

### Finned block heat exchanger

Made of 8mm diameter copper pipes and aluminium fins. The heat exchangers' particular design makes it possible to speed up to the maximum the defrost phases in the versions with heat pump with obvious benefits to seasonal efficiency while operating in heating mode.

### Electronic microprocessor control

The electronic controller enables the complete control of the MPE unit. It can be easily accessed through a polycarbonate flap with IP65 protection rating. It implements the compressor regulation logic and allows the complete management of the unit's other parts, the reversal of the cooling cycle, and the alarms.



## CONFIGURATOR

The models are completely configurable by selecting the version and the options. To the right is shown an example of configuration.

Version	Field	1	2	3	4	5	6	7	8	9	10	11	12	13
MPET18COAC		A	1	S	0	E	0	3	M	2	0	G	2	1

To verify the compatibility of the options, use the selection software or the price list.

### AVAILABLE VERSIONS

#### Only cooling versions

**MPE..COAC**

Power supply 400V-3N-50Hz

**MPE..CZAC**

Power supply 400V-3N-50H + circuit breaker

#### Reversible heat pump versions

**MPE..H0AA**

Power supply 400V-3N-50Hz

**MPE..HMAA**

Power supply 230V-1N-50H

**MPE..HZAA**

Power supply 400V-3N-50H + circuit breaker

**MPE..H4AA**

Power supply 230V-1N-50H + circuit breaker

### CONFIGURATION OPTIONS

- |  |   |
|--|---|
| <p><b>1 Expansion valve</b></p> <ul style="list-style-type: none"> <li>0 Mechanical</li> <li>A Electronic</li> </ul> <p><b>2 Water pump and accessories</b></p> <ul style="list-style-type: none"> <li>0 Absent</li> <li>1 LP pump + expansion vessel</li> <li>2 LP run and standby double pump + expansion vessel (advanced controller required)</li> </ul> <p><b>3 Water buffer tank</b></p> <ul style="list-style-type: none"> <li>0 Absent</li> <li>S Selected</li> </ul> <p><b>4 Partial heat recovery</b></p> <ul style="list-style-type: none"> <li>0 Absent</li> <li>D Desuperheater with pump activation contact</li> </ul> <p><b>5 Air flow modulation</b></p> <ul style="list-style-type: none"> <li>C Condensation control by phase-cut fans</li> <li>E Condensation control performed by EC fans</li> </ul> <p><b>6 Antifreezing kit</b></p> <ul style="list-style-type: none"> <li>0 Absent</li> <li>E Evaporator (tandem unit advanced controller required)</li> <li>P Evaporator and pump (tandem unit advanced controller required)</li> <li>S Evaporator, water pump and water buffer tank (tandem unit advanced controller required)</li> </ul> <p><b>7 Acoustic insulation and attenuation</b></p> <ul style="list-style-type: none"> <li>0 Absent</li> <li>1 Compressor compartment acoustic insulation</li> <li>2 Compressor sound blanket</li> <li>3 Compressor compartment acoustic insulation and sound blanket</li> </ul> <p><b>8 Refrigerant pipework accessories</b></p> <ul style="list-style-type: none"> <li>0 Absent</li> <li>M Refrigerant pressure gauges</li> </ul> <p><b>9 Remote control / Serial communication</b></p> | <ul style="list-style-type: none"> <li>0 Absent</li> <li>2 RS485 serial board (Carel / Modbus protocol)</li> <li>B BACNET IP / PCOWEB serial board (advanced controller required)</li> <li>F BACNET MS/TP / PCONET board (advanced control required)</li> <li>G BACNET IP / PCOWEB serial board + supervision software Gweb (advanced controller required)</li> <li>L LON FTT10 serial board (advanced controller required)</li> <li>S Remote simplified user panel</li> <li>X Remote simplified user panel for advanced controller</li> </ul> <p><b>10 Special coils / Protective treatments</b></p> <ul style="list-style-type: none"> <li>0 Standard</li> <li>B Pre-painted fins with epoxy painting</li> <li>C Cataphoresis</li> <li>I Hydrophilic</li> <li>R Copper-copper</li> </ul> <p><b>11 Outdoor finned coil heat exchanger protection</b></p> <ul style="list-style-type: none"> <li>0 Absent</li> <li>G Outdoor finned coil heat exchanger protection grille</li> </ul> <p><b>12 Compressors options</b></p> <ul style="list-style-type: none"> <li>0 Absent</li> <li>1 Power factor capacitors</li> <li>2 Soft starter</li> <li>3 Power factor capacitors + soft starter</li> <li>4 Crankcase compressor heater (CHILLER), outdoor coil trace heater (HP)</li> </ul> <p><b>13 Onboard controller</b></p> <ul style="list-style-type: none"> <li>1 Basic</li> <li>2 Advanced</li> <li>3 Advanced + GSM modem board</li> <li>4 Advanced + clock card</li> </ul> |
|--|---|

## ACCESSORIES

<b>1701546</b>	Remote simplified user panel	<b>RYPAM</b>	Rubber anti vibration shock mounts
<b>RYKAMF</b>	Spring anti vibration shock mounts	<b>RYRT40</b>	Tank module connection kit
<b>RYMCL</b>	MyChiller Plus (RS485 serial board and advanced controller required)	<b>RYT40</b>	Inertial tank module for under-base installation
<b>RYMCM</b>	MyChiller Base (RS485 serial board and advanced controller required)		

# Air chillers and heat pumps MPE

## RATED TECHNICAL DATA MPE C

MPE C		T18	T23	T25	T30	T34	T42	T54
Power supply	V-ph-Hz	400 - 3N - 50						
Cooling capacity	(1)(E) kW	19,9	23,4	26,0	31,9	35,9	42,5	54,6
Total power input	(1)(E) kW	7,80	8,70	8,90	10,7	12,8	15,0	18,7
EER	(1)(E)	2,56	2,68	2,94	2,97	2,79	2,83	2,93
SEER	(2)(E)	4,10	4,10	4,10	4,10	4,11	4,10	4,10
Water flow	(1) l/h	3435	4041	4480	5489	6181	7320	9400
Water pressure drop	(1)(E) kPa	52	48	35	34	42	37	41
Available pressure head - LP pumps	(1) kPa	111	92	96	126	101	98	145
Maximum current absorption	A	32,0	39,0	40,0	44,0	48,0	44,0	55,0
Start up current	A	85	95	96	100	116	164	177
Startup current with soft starter	A	65	73	74	78	90	123	134
Compressors / circuits		2 / 1						
Expansion vessel volume	dm <sup>3</sup>	5	5	5	8	8	8	8
Buffer tank volume	dm <sup>3</sup>	50	50	50	125	125	125	125
Sound power level	(3)(E) dB(A)	72	73	73	73	73	74	81
Transport weight unit with pump and tank	kg	232	256	260	448	484	521	643
Operating weight unit with pump and full tank	kg	282	306	309	555	591	663	751

MPE C		T57	T64	T71
Power supply	V-ph-Hz	400 - 3N - 50		
Cooling capacity	(1)(E) kW	56,9	65,8	71,5
Total power input	(1)(E) kW	19,9	22,6	26,2
EER	(1)(E)	2,86	2,91	2,73
SEER	(2)(E)	4,11	4,10	4,12
Water flow	(1) l/h	9795	11335	12306
Water pressure drop	(1)(E) kPa	37	37	37
Available pressure head - LP pumps	(1) kPa	147	142	136
Maximum current absorption	A	58,0	64,0	70,0
Start up current	A	182	196	238
Startup current with soft starter	A	138	149	179
Compressors / circuits		2 / 1		
Expansion vessel volume	dm <sup>3</sup>	8	8	8
Buffer tank volume	dm <sup>3</sup>	125	125	125
Sound power level	(3)(E) dB(A)	81	81	81
Transport weight unit with pump and tank	kg	665	685	786
Operating weight unit with pump and full tank	kg	773	793	894

(1) Outdoor air temperature 35°C, water temperature 12°C / 7°C (EN14511:2022)

(2)  $\eta$  efficiency values for heating and cooling are respectively calculated by the following formulas:  $[\eta = SCOP / 2,5 - F(1) - F(2)]$  e  $[\eta = SEER / 2,5 - F(1) - F(2)]$ . For further information, please refer to the technical document "ErP 2009/125/EC DIRECTIVE" in the catalogue introducing pages, or to the EN14825:2022 regulation.

(3) Sound power level measured according to ISO 9614

(E) EUROVENT certified data

**RATED TECHNICAL DATA MPE H**

MPE H			004M	005M	007M	008	008M	009	010	010M	
Power supply		V-ph-Hz	230 - 1 - 50	230 - 1 - 50	230 - 1 - 50	400 - 3N - 50	230 - 1 - 50	400 - 3N - 50	400 - 3N - 50	230 - 1 - 50	
Cooling capacity	(1)(E)	kW	4,00	5,00	6,70	8,30	8,10	9,20	9,10	9,00	
Total power input	(1)(E)	kW	1,30	1,70	2,20	3,10	3,40	3,00	3,30	3,30	
EER	(1)(E)		2,98	2,94	3,03	2,64	2,41	3,08	2,76	2,75	
SEER	(2)(E)		3,16	3,02	3,22	3,17	2,98	3,54	3,15	3,15	
Water flow	(1)	l/h	687	858	1151	1424	1401	1585	1568	1554	
Water pressure drop	(1)(E)	kPa	5	5	9	6	6	16	33	33	
Available pressure head - LP pumps	(1)	kPa	77	74	55	67	67	146	115	115	
Heating capacity	(3)(E)	kW	4,70	5,90	7,50	9,90	10,3	10,5	10,9	11,0	
Total power input	(3)(E)	kW	1,50	1,80	2,20	3,30	3,70	3,40	3,60	3,60	
COP	(3)(E)		3,23	3,18	3,46	2,97	2,81	3,12	3,02	3,04	
SCOP	(2)(E)		3,45	3,59	3,57	3,51	3,26	3,30	3,05	3,05	
Heating energy efficiency class	(4)(E)		A+								
Water flow	(3)	l/h	815	1017	1307	1717	1781	1823	1890	1896	
Water pressure drop	(3)(E)	kPa	5	5	11	8	8	21	46	46	
Available pressure head - LP pumps	(3)	kPa	76	73	54	65	64	143	107	107	
Maximum current absorption		A	9,00	11,0	11,0	9,00	17,6	8,00	12,0	24,0	
Start up current		A	38	44	44	49	88	43	49	98	
Startup current with soft starter		A	26	30	30	34	66	29	33	68	
Compressors / circuits			1 / 1								
Expansion vessel volume		dm <sup>3</sup>	1	1	1	1	1	5	5	5	
Buffer tank volume		dm <sup>3</sup>	20	20	20	20	20	30	30	30	
Sound power level	(5)(E)	dB(A)	66	66	68	67	82	69	69	69	
Transport weight unit with pump and tank		kg	114	118	123	127	120	211	211	211	
Operating weight unit with pump and full tank		kg	123	127	132	136	129	227	227	227	

MPE H			013	014	015	018	020	021	024
Power supply		V-ph-Hz	400 - 3N - 50						
Cooling capacity	(1)(E)	kW	12,6	14,0	14,6	16,7	20,8	20,1	23,2
Total power input	(1)(E)	kW	4,20	4,60	5,30	6,40	7,80	7,00	8,20
EER	(1)(E)		2,98	3,01	2,78	2,61	2,66	2,88	2,83
SEER	(2)(E)		3,45	3,25	3,39	3,17	3,14	3,38	3,32
Water flow	(1)	l/h	2174	2409	2516	2886	3592	3459	4000
Water pressure drop	(1)(E)	kPa	59	10	36	49	57	18	47
Available pressure head - LP pumps	(1)	kPa	81	139	102	130	109	140	109
Heating capacity	(3)(E)	kW	15,3	15,9	17,7	20,1	23,9	24,6	27,3
Total power input	(3)(E)	kW	4,80	5,00	5,60	6,80	8,00	7,30	8,30
COP	(3)(E)		3,19	3,17	3,16	2,94	2,99	3,39	3,28
SCOP	(2)(E)		3,34	3,62	3,47	3,22	3,22	3,55	3,44
Heating energy efficiency class	(4)(E)		A+						
Water flow	(3)	l/h	2642	2764	3060	3479	4139	4264	4720
Water pressure drop	(3)(E)	kPa	86	12	52	70	75	27	63
Available pressure head - LP pumps	(3)	kPa	69	138	95	116	93	135	106
Maximum current absorption		A	15,0	11,0	18,0	22,0	24,0	24,0	26,0
Start up current		A	64	67	67	76	105	158	159
Startup current with soft starter		A	44	46	46	51	72	110	110
Compressors / circuits			1 / 1						
Expansion vessel volume		dm <sup>3</sup>	5	5	5	5	5	5	5
Buffer tank volume		dm <sup>3</sup>	30	50	30	50	50	50	50
Sound power level	(5)(E)	dB(A)	69	71	69	71	71	74	72
Transport weight unit with pump and tank		kg	216	219	219	265	281	281	297
Operating weight unit with pump and full tank		kg	232	236	236	301	317	317	333

(1) Outdoor air temperature 35°C, water temperature 12°C / 7°C (EN14511:2022)

(2)  $\eta$  efficiency values for heating and cooling are respectively calculated by the following formulas: [ $\eta = SCOP / 2,5 - F(1) - F(2)$ ] e [ $\eta = SEER / 2,5 - F(1) - F(2)$ ]. For further information, please refer to the technical document "ErP 2009/125/EC DIRECTIVE" in the catalogue introducing pages, or to the EN14825:2022 regulation.

(3) Outdoor air temperature dry bulb 7°C / wet bulb 6°C, water temperature 40°C / 45°C (EN 14511:2022)

(4) Seasonal energy efficiency class for LOW TEMPERATURE room heating under AVERAGE climatic conditions [EUROPEAN REGULATION No 811/2013]

(5) Sound power level measured according to ISO 9614

(E) EUROVENT certified data

# Air chillers and heat pumps MPE

## RATED TECHNICAL DATA MPE H

MPE H		027	028	T30	032	T34	035	040
Power supply		400 - 3N - 50						
Cooling capacity	(1)(E) kW	26,0	27,4	29,4	30,8	33,3	34,1	38,8
Total power input	(1)(E) kW	9,5	8,80	10,5	10,2	12,7	11,7	12,9
EER	(1)(E)	2,74	3,11	2,80	3,02	2,62	2,91	3,00
SEER	(2)(E)	3,32	3,71	3,85	3,58	3,78	3,58	3,66
Water flow	(1) l/h	4469	4722	5062	5309	5736	5873	6686
Water pressure drop	(1)(E) kPa	32	39	29	49	37	39	42
Available pressure head - LP pumps	(1) kPa	118	139	146	120	130	126	115
Heating capacity	(3)(E) kW	30,0	31,4	34,5	35,8	39,3	39,3	44,3
Total power input	(3)(E) kW	9,00	9,30	11,1	10,7	13,0	11,8	13,4
COP	(3)(E)	3,32	3,37	3,12	3,34	3,03	3,34	3,31
SCOP	(2)(E)	3,57	3,60	3,66	3,64	3,70	3,70	3,64
Heating energy efficiency class	(4)(E)	A+						
Water flow	(3) l/h	5189	5438	5975	6190	6801	6809	7675
Water pressure drop	(3)(E) kPa	43	50	39	64	51	51	53
Available pressure head - LP pumps	(3) kPa	115	134	137	113	117	118	111
Maximum current absorption	A	32,0	32,0	37,0	34,0	43,0	38,0	40,0
Start up current	A	133	134	86	166	96	162	164
Startup current with soft starter	A	91	91	64	114	71	111	112
Compressors / circuits		1 / 1	1 / 1	2 / 1	1 / 1	2 / 1	1 / 1	1 / 1
Expansion vessel volume	dm <sup>3</sup>	5	8	8	8	8	8	8
Buffer tank volume	dm <sup>3</sup>	50	125	125	125	125	125	125
Sound power level	(5)(E) dB(A)	72	73	76	73	72	73	75
Transport weight unit with pump and tank	kg	313	427	448	456	484	487	516
Operating weight unit with pump and full tank	kg	350	534	555	563	591	595	624

MPE H		T42	054	T54	T61	066	T69	T76
Power supply		400 - 3N - 50						
Cooling capacity	(1)(E) kW	42,5	51,8	53,2	60,5	62,5	68,5	74,5
Total power input	(1)(E) kW	15,2	18,1	18,6	21,7	24,5	24,0	28,0
EER	(1)(E)	2,79	2,86	2,86	2,79	2,55	2,85	2,66
SEER	(2)(E)	3,76	3,57	3,77	3,78	3,18	3,42	3,97
Water flow	(1) l/h	7320	8938	9173	10425	10763	11800	12837
Water pressure drop	(1)(E) kPa	37	56	51	64	53	50	58
Available pressure head - LP pumps	(1) kPa	98	107	138	122	89	129	115
Heating capacity	(3)(E) kW	48,0	61,2	60,3	67,8	75,5	76,6	85,2
Total power input	(3)(E) kW	16,1	18,9	18,9	22,1	23,8	23,9	27,4
COP	(3)(E)	2,98	3,24	3,19	3,07	3,18	3,21	3,11
SCOP	(2)(E)	3,68	3,58	3,55	3,47	3,48	3,67	3,56
Heating energy efficiency class	(4)(E)	A+						
Water flow	(3) l/h	8308	10578	10440	11736	13063	13266	14740
Water pressure drop	(3)(E) kPa	47	82	58	74	81	56	69
Available pressure head - LP pumps	(3) kPa	84	90	137	116	66	124	105
Maximum current absorption	A	44,0	46,0	48,0	53,0	41,0	57,0	69,0
Start up current	A	164	163	177	187	165	202	229
Startup current with soft starter	A	123	110	130	138	112	149	169
Compressors / circuits		2 / 1	1 / 1	2 / 1	2 / 1	1 / 1	2 / 1	2 / 1
Expansion vessel volume	dm <sup>3</sup>	8	8	8	8	8	8	8
Buffer tank volume	dm <sup>3</sup>	125	125	125	125	125	125	125
Sound power level	(5)(E) dB(A)	74	78	81	81	78	81	81
Transport weight unit with pump and tank	kg	521	521	643	665	558	685	786
Operating weight unit with pump and full tank	kg	629	630	751	773	665	793	894

(1) Outdoor air temperature 35°C, water temperature 12°C / 7°C (EN14511:2022)

(2)  $\eta$  efficiency values for heating and cooling are respectively calculated by the following formulas:  $[\eta = SCOP / 2,5 - F(1) - F(2)]$  e  $[\eta = SEER / 2,5 - F(1) - F(2)]$ . For further information, please refer to the technical document "ErP 2009/125/EC DIRECTIVE" in the catalogue introducing pages, or to the EN14825:2022 regulation.

(3) Outdoor air temperature dry bulb 7°C / wet bulb 6°C, water temperature 40°C / 45°C (EN14511:2022)

(4) Seasonal energy efficiency class for LOW TEMPERATURE room heating under AVERAGE climatic conditions [EUROPEAN REGULATION No 811/2013]

(5) Sound power level measured according to ISO 9614

(E) EUROVENT certified data

DIMENSIONAL DRAWINGS

MPE 4 - 8

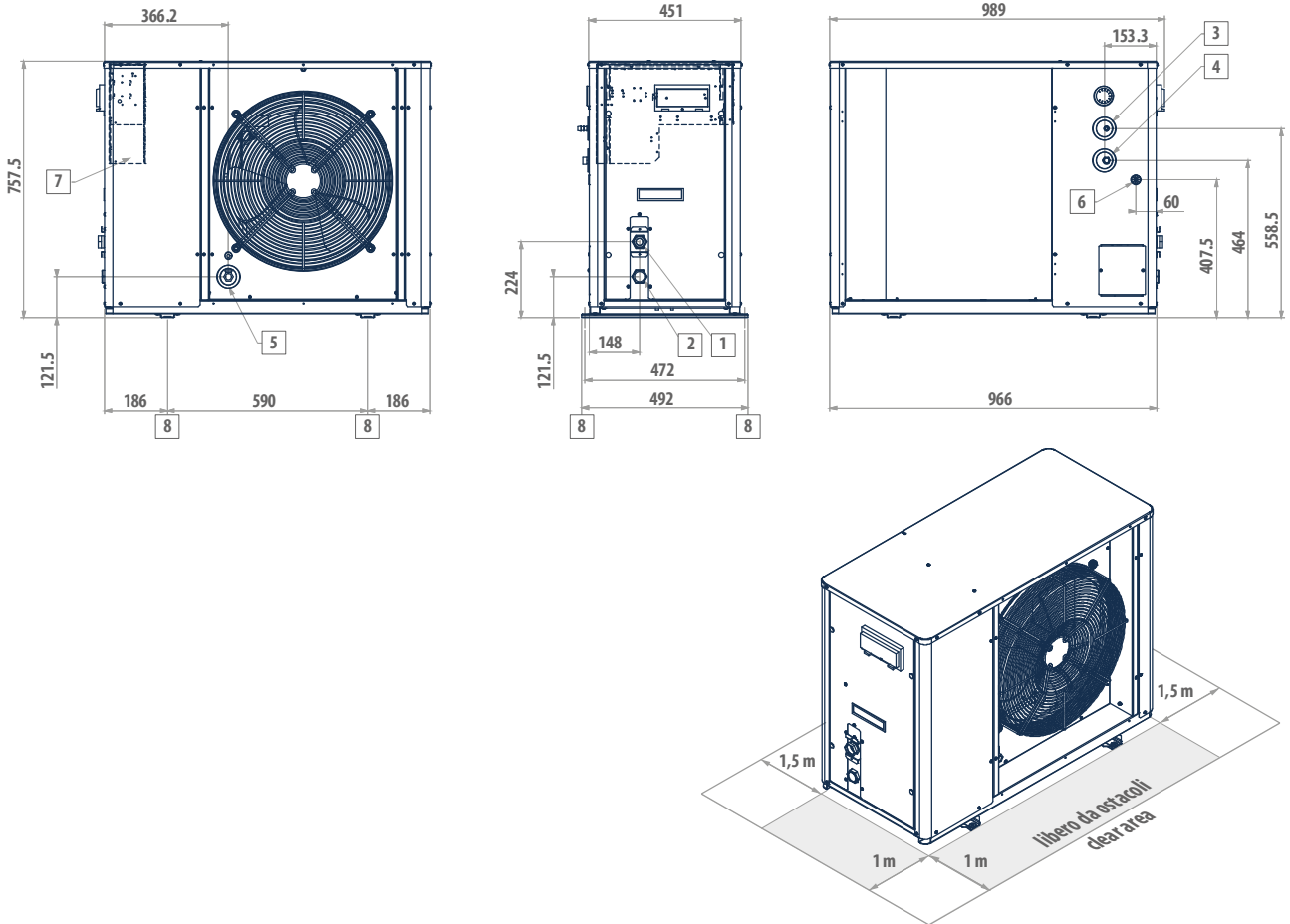

**LEGEND**

1	Water inlet 1" female
2	Water outlet 1" female
3	Safety valve discharge outlet provided with rubber ring holder
4	Water supply 1/2" male (optional tap)
5	Water drainage 1/2" female
6	Power supply $\varnothing$ 28 mm
7	Electric control board
8	Fastening points for vibration dampers (accessory)

## DIMENSIONAL DRAWINGS

### MPE 9 - 15

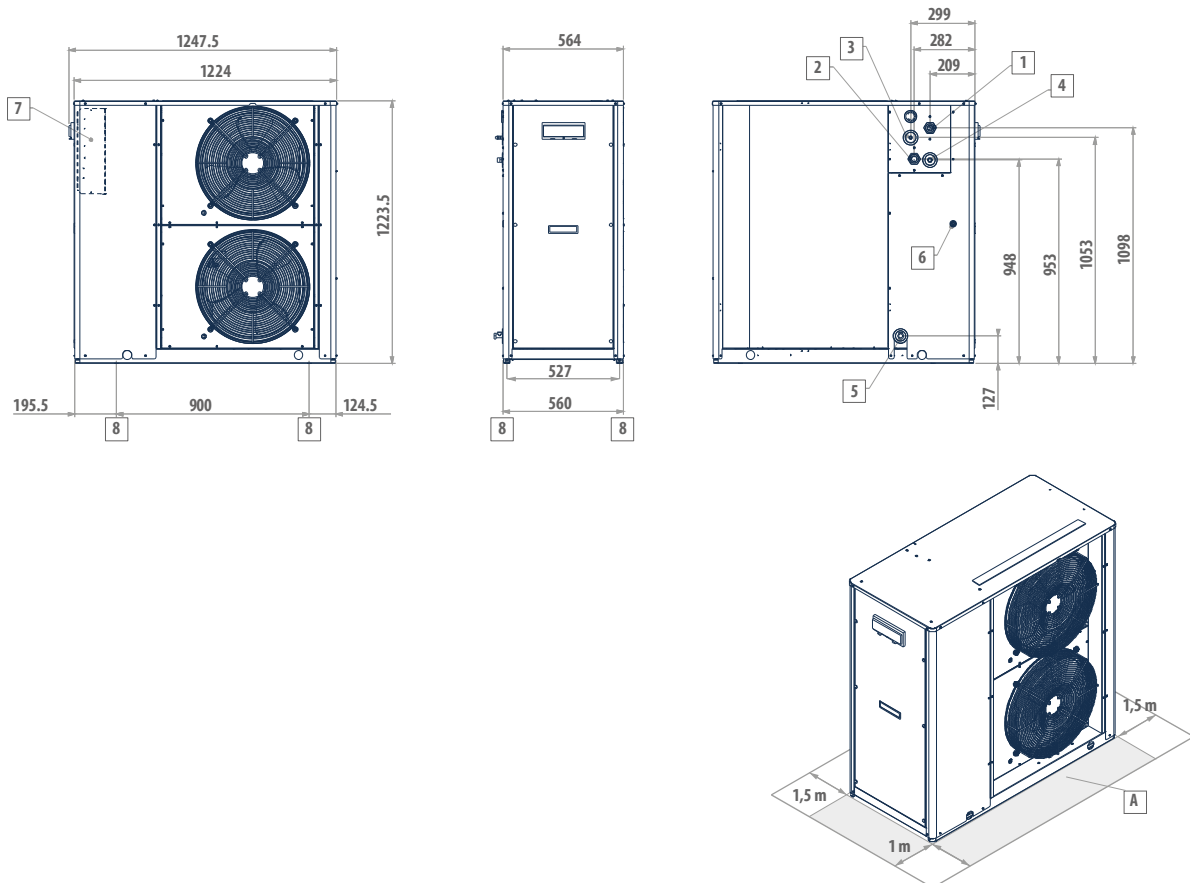

#### LEGEND

1	Water inlet 1" 1/4 female
2	Water outlet 1" 1/4 female
3	Safety valve discharge outlet provided with rubber ring holder
4	Water supply 1/2" male (optional tap)
5	Water drainage 1/2" female
6	Power supply $\varnothing$ 28 mm
7	Electric control board
8	Vibration dumpers

DIMENSIONAL DRAWINGS

MPE 14 H + MPE 18 - 27

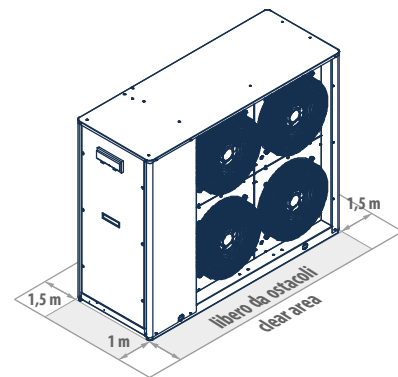
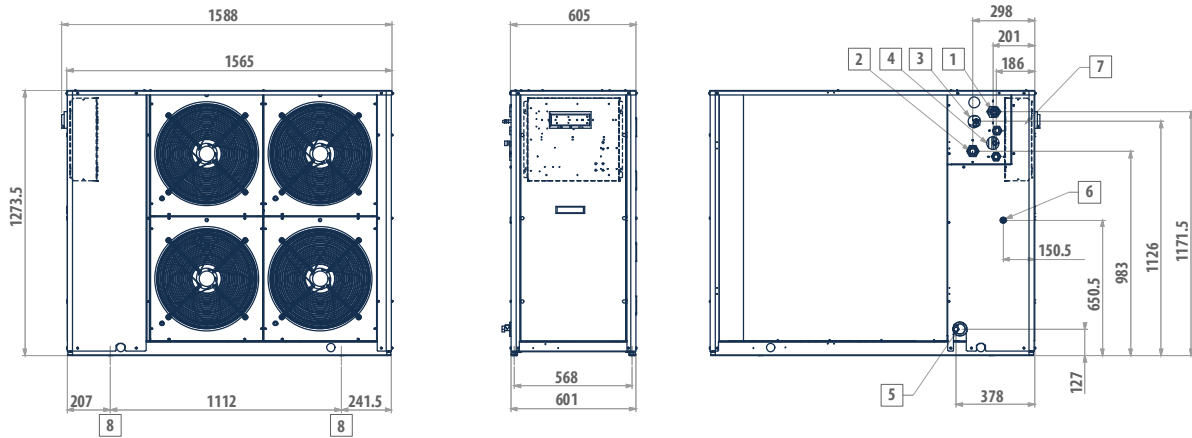

LEGEND

1	Water inlet 1" 1/4 female
2	Water outlet 1" 1/4 female
3	Safety valve discharge outlet provided with rubber ring holder
4	Water supply 1/2" male (optional tap)
5	Water drainage 1/2" female
6	Power supply $\varnothing$ 28 mm
7	Electric control board
8	Vibration dumpers



## DIMENSIONAL DRAWINGS

### MPE T18 - T23 - T25

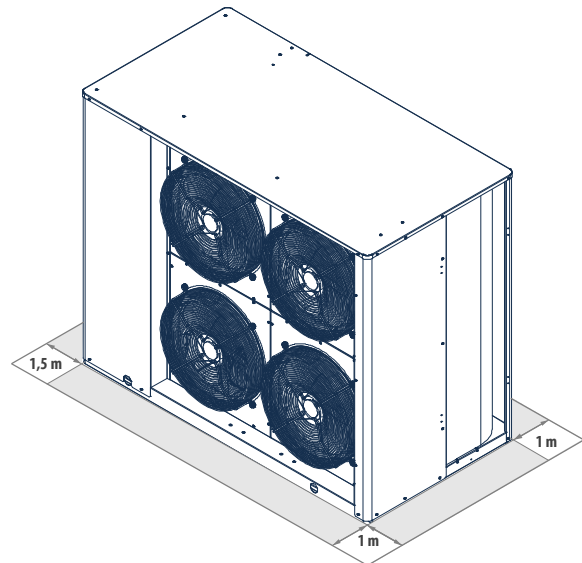
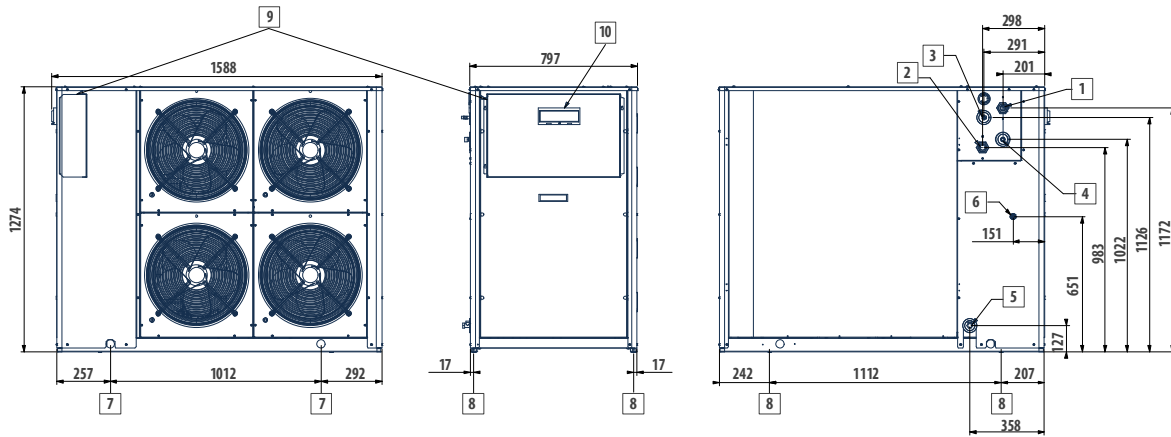

#### LEGEND

1	Water inlet 1" 1/4 female
2	Water outlet 1" 1/4 female
3	Safety valve discharge outlet provided with rubber ring holder
4	Water supply 1/2" male (optional tap)
5	Water drainage 1/2" female
6	Power supply $\varnothing$ 28 mm
7	Lifting points
8	Vibration dumpers
9	Electric control board
10	User interface

DIMENSIONAL DRAWINGS

MPE 28 - 40 - MPE T30 - T45

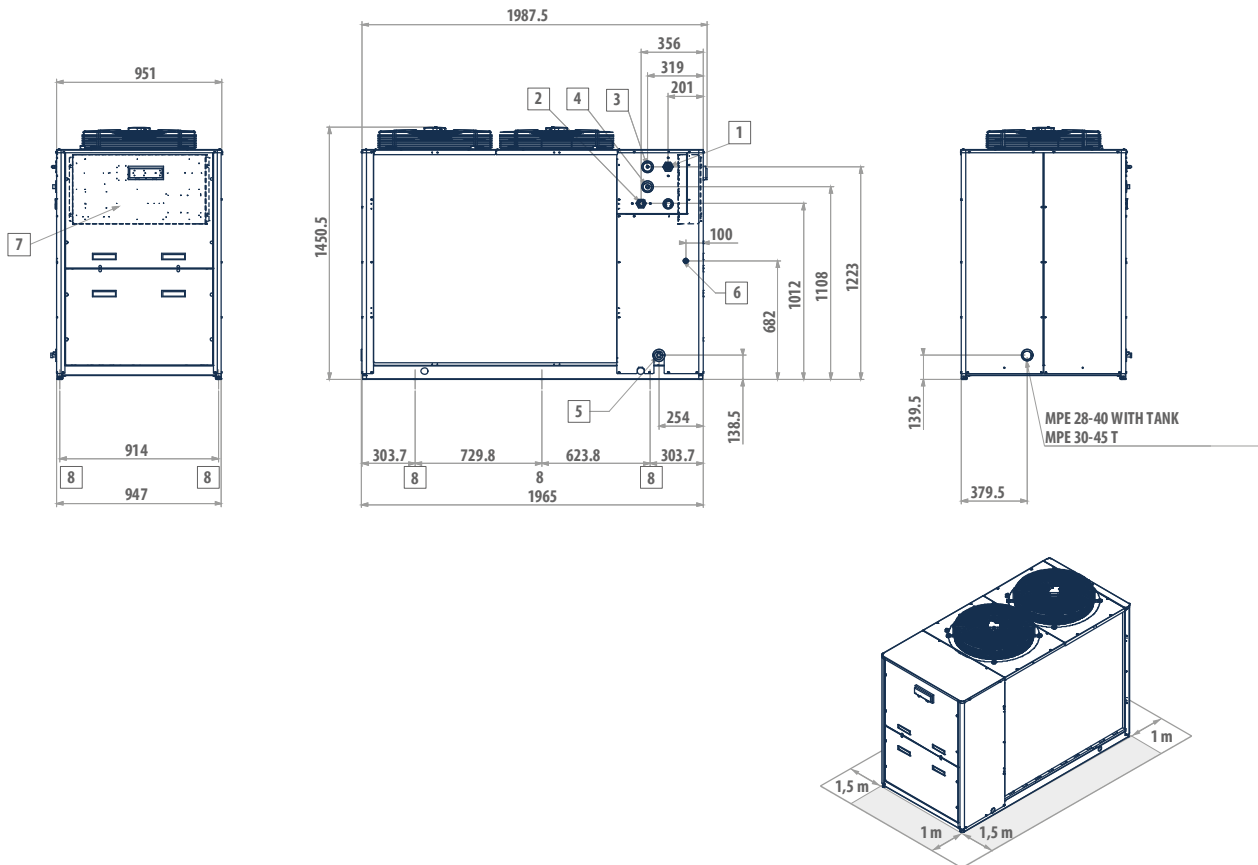

LEGEND

1	Water inlet 1" 1/4 female
2	Water outlet 1" 1/4 female
3	Safety valve discharge outlet provided with rubber ring holder
4	Water supply 1/2" male (optional tap)
5	Water drainage 1/2" female
6	Power supply $\varnothing$ 37 mm
7	Electric control board
8	Vibration dumpers

## DIMENSIONAL DRAWINGS

MPE 54 ÷ 66

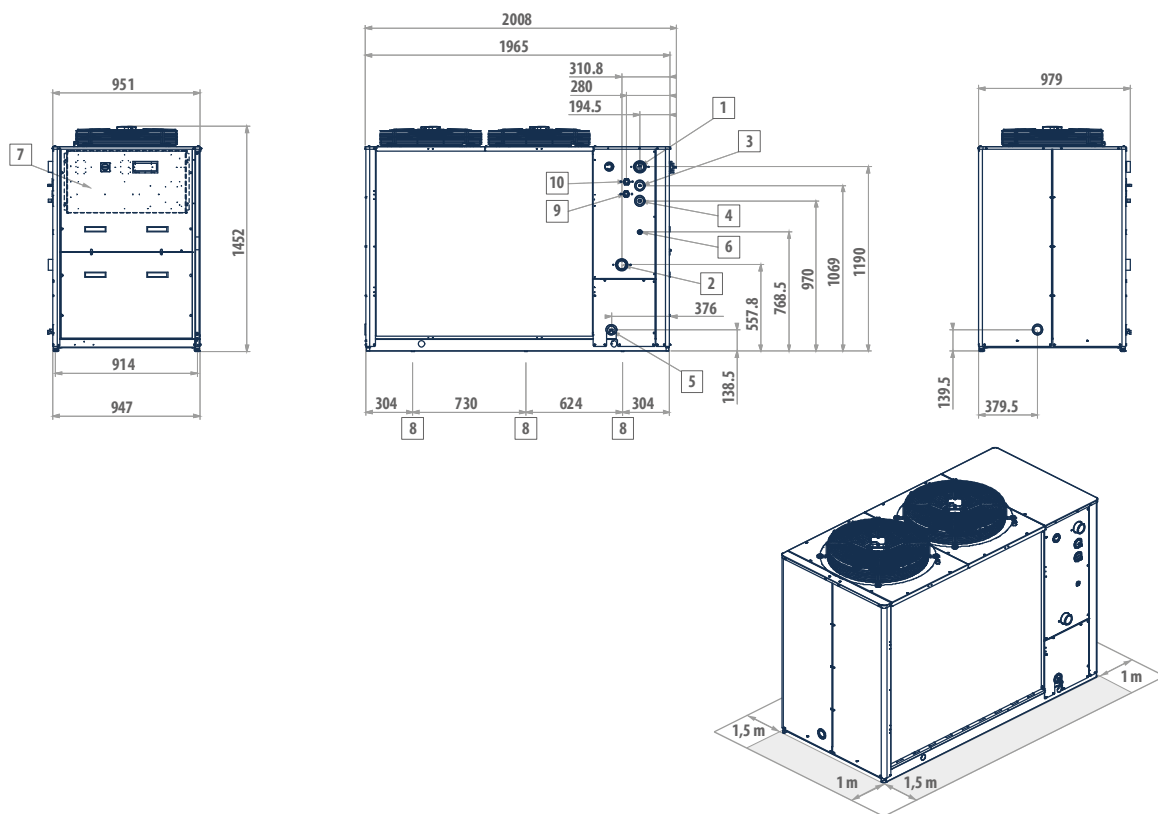

### LEGEND

1	Water inlet 2" female
2	Water outlet 2" female
3	Safety valve discharge outlet provided with rubber ring holder
4	Water supply 1/2" male
5	Water drainage 1/2" female
6	Power supply
7	Electric control board
8	Fastening points for vibration dampers (accessory)

DIMENSIONAL DRAWINGS

MPET54 ÷ T76

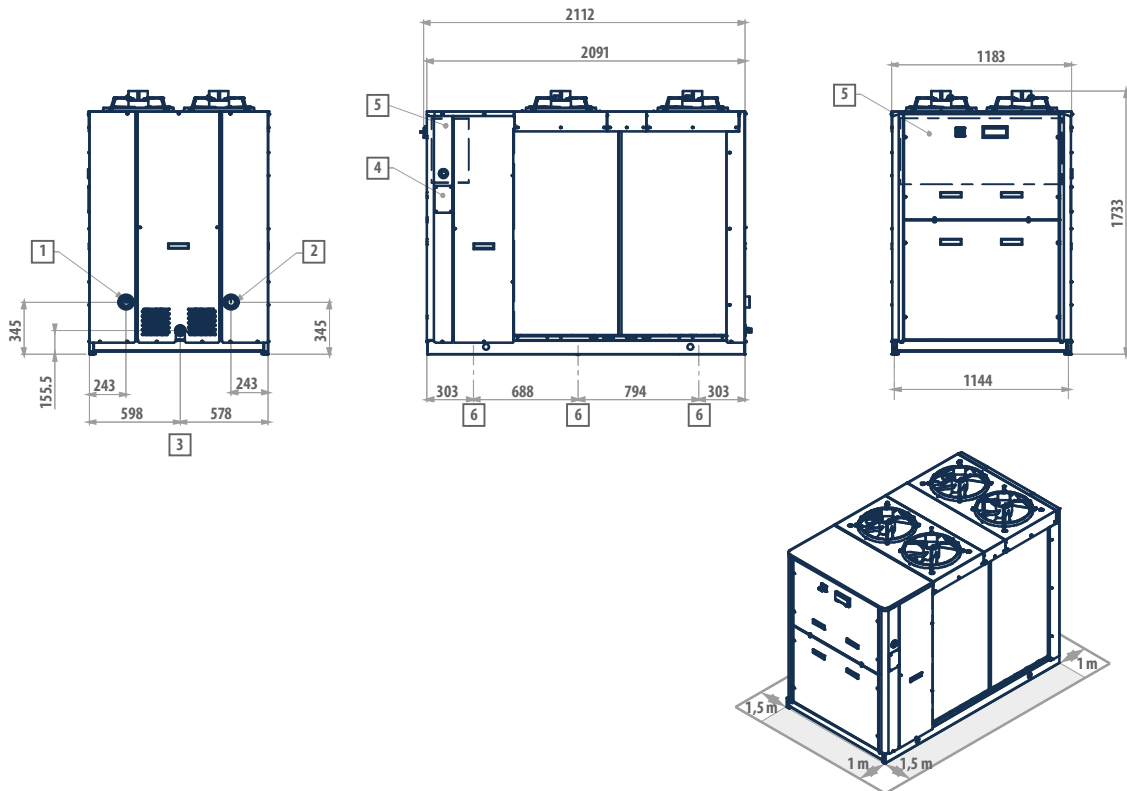

**LEGEND**

1	Water inlet 2" female
2	Water outlet 2" female
3	Water drainage 1/2" female
4	Power supply
5	Electric control board
6	Fastening points for vibration dampers