

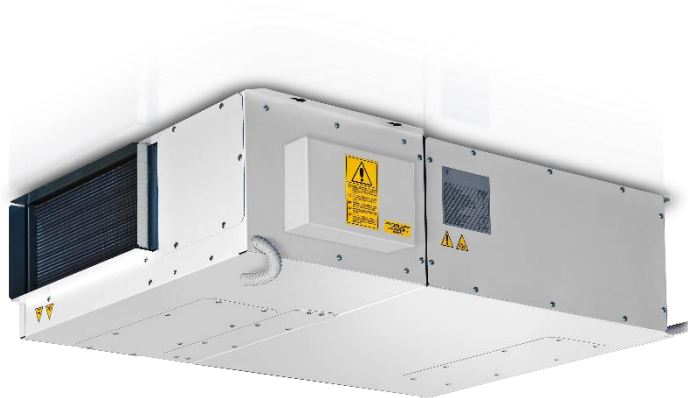

REV

Vertical dehumidifiers with ultra-high efficiency recovery unit



RER

Horizontal dehumidifiers with ultra-high efficiency recovery unit

**USE MAINTENANCE AND
INSTALLATION MANUAL**

RER - REV

Dehumidifier with high-efficiency heat recovery



**AVVERTENZA
CAUTION**

READ THIS MANUAL CAREFULLY BEFORE USING THE UNIT

Dear Customer,

thank you for choosing our product. We are pleased to provide you with this manual to obtain the best use of our product, and for maximum comfort and increased safety.

Please read the recommendations described in the following pages carefully and make the manual available to the personnel who will be responsible for managing and maintaining the unit.

Our company is at your disposal for any questions you may have both during the unit start-up phase or at any other time.

Our Technical Department is at your disposal for any assistance and spare parts you may require, especially during routine or extraordinary maintenance.

Please find our contact details below for a more rapid service:

HiDew
Dehumidifiers

HiDew S.r.l.
info@hidew.it - www.hidew.it

Operational headquarters
Via dell'Artigianato, 5 – 35026 – Conselve (PD) – Italy
Tel +39 049 9502511

Registered office
Viale Spagna, 31/33 - 35020 - Tribano (PD) - Italy
Tel +39 049/9588511 - Fax +39 049/9588522

EEE Register: IT18080000010604

SUMMARY

1	FOREWORD	5
1.1	RESPONSIBILITY.....	6
1.2	RULES FOR CORRECT OPERATION.....	6
1.3	SERVICE RULES.....	7
1.4	INTENDED USE.....	8
1.5	RESIDUAL RISK AREAS.....	8
1.6	INTERVENTION AND MAINTENANCE.....	8
1.7	GENERAL SAFETY RULES	9
2	PRODUCT DESCRIPTION	10
2.1	SERIES.....	10
2.2	AIR FLUXES.....	11
2.3	REV UNIT POSSIBLE INSTALLATIONS	19
2.4	STRUCTURE	20
2.5	OPERATIONAL AND FUNCTIONAL LIMITS	20
2.6	OPTIONS AND FUNCTIONS	21
3	REFRIGERANT AND HYDRAULIC CIRCUITS.....	24
3.1	FUNCTIONAL SCHEMES	24
3.2	PROJECT CRITERIA	27
4	ELECTRIC CIRCUITS.....	27
4.1	ELECTRICAL DEVICES.....	27
5	DISPLAY.....	28
5.1	BUTTONS.....	28
5.2	MAIN MASK.....	29
5.3	USER MENU.....	29
5.4	ALARMS MENU.....	32
5.5	UNIT STATUS MENU	32
5.6	TIME BANDS MENU	33
5.7	OTHER SCREENS.....	34
6	TECHNICAL DATA	35
6.1	TECHNICAL DATA SHEET	35
6.2	AIR FLOWS AND PRESSURE	38
6.3	HYDRAULIC CIRCUIT LOAD LOSSES	39
6.4	TYPE W UNIT COOLING CAPACITY.....	40
7	MAINTENANCE AND PROBLEM SOLVING.....	42
7.1	FAULTS AND ANOMALIES	42
7.2	MAINTENANCE TABLE	44
7.3	ORDINARY MAINTENANCE	45
7.4	EXTRAORDINARY MAINTENANCE.....	47
8	DISMANTLING OF THE UNIT	48
8.1	AMBIENT PROTECTION.....	48
8.2	MANAGEMENT OF WASTE ELECTRICAL AND ELECTRONIC EQUIPMENT (WEEE)	48
9	INSTALLATION	49
9.1	PREAMBLE.....	49
9.2	POSITIONING	50
9.3	DUCTING.....	54
9.4	HYDRAULIC CONNECTIONS.....	56
9.5	ELECTRICAL CONNECTIONS	57
9.6	FIRST START, CALIBRATION AND CONFIGURATIONS	62

FOR THE DIMENSIONAL DRAWINGS, SEE THE DRAWINGS ATTACHMENT

1 FOREWORD

This manual indicates the intended use of the unit and provides instructions on transportation, installation, assembly, adjustment and use. It provides information on maintenance, ordering spare parts, the presence of residual risks and personnel training.

The user manual must be read and used as follows:

- Every unit operator and the staff in charge must carefully read the entire manual and comply with the indications given;
- The employer is obliged to ensure that the operator possesses the skills required to operate the unit and has carefully read the manual; the employer must also provide the operator with details about the risk of accidents, especially those deriving from noise, about the personal protective equipment provided and the general accident prevention regulations, required by international laws or regulations or those applicable in the country of use;
- The manual must always be available to the user, managers and operators in charge of transportation, installation, use, maintenance, repairs and final dismantling;
- Keep the manual away from sources of humidity and heat and treat it as an integral part of the unit for its entire duration, passing on the manual to any other user or subsequent owner of the unit;
- Make sure that any update is included in the text;
- Under no circumstances are any parts of the manual to be removed, torn or rewritten. If the manual is mislaid or partially damaged and, therefore, the contents can no longer be fully read, a new manual should be requested from the manufacturer by communicating the serial number of the machine found on the data plate.

Pay utmost attention to the following symbols. Their purpose is to highlight specific information such as:

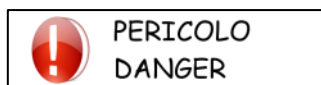

Dangerous situations that could arise while using the unit, in order to guarantee personal safety.



Dangerous situations that could arise while using the unit, in order to prevent damaging property and the unit itself.



Additional information or suggestions for the unit to be used correctly.

The manufacturer has the right to update the production and manuals, without being obliged to update previous versions, except for exceptional cases.

This manual reflects the applicable technology at the time the unit is sold and cannot be considered inadequate due to subsequent updates based on new technology.

For any requests for updates of the use and maintenance manual or supplements, which are to be considered an integral part of the manual, please refer to the contact information indicated in this manual.

Contact the manufacturer for further information and to submit any proposals on how to improve the manual.

The manufacturer kindly asks you to communicate the address of the new owner if the unit is passed on to third parties, in order to facilitate the forwarding of any supplements of the manual to the new user.

1.1 RESPONSIBILITY

The unit is covered by the warranty in accordance with the contractual agreements established at the time of sale.

The manufacturer is deemed exempt from any liability and obligation, and the warranty required by the sales contract will be voided for any accident or damage to persons or property, which may derive from:



Failure to comply with the instructions provided in this manual with regard to operation, use, installation, maintenance and events which are however unrelated to normal and correct use of the unit;

- changes made to the unit or to the safety devices without written authorisation from the manufacturer;
- non-authorised attempts at repair;
- negligence in constant maintenance or use of non-original spare parts.

In any case, if the user attributes the accident to a defect in the unit, they must prove that the damage caused was a main and direct consequence of this “defect”.

1.2 RULES FOR CORRECT OPERATION

Failure to follow the instructions given in this manual with regard to operation, use, maintenance and any events unrelated to the normal and correct use of the unit shall invalidate the warranty immediately.

In all lifting operations make sure that the unit is properly secured to prevent accidental falls or overturning. Do not move or lift the unit by the removable panels. The unit must be started up for the first time only by qualified personnel authorised by the manufacturer.

All the operators must comply with international accident prevention regulations and those applicable in the country of use in order to prevent potential accidents. Install the unit in places where there is no risk of explosion, corrosion (near the sea), fire and where there are no vibrations and electromagnetic fields. It is also prohibited to operate in any way other than that stipulated or disregard required safety operations.

It has not been possible to eliminate certain residual risks during the design phase, found in some areas of the unit, or protect them with guards due to specific features of the unit. Each operator must be aware of the residual risks present in the unit in order to prevent any accidents.

Once the unit has been cleaned, the operator must make sure there are no worn or damaged parts or others that are not fastened securely; otherwise, a maintenance technician should be contacted.

Maintenance should be performed by specialised personnel with the unit disconnected from the power supply. Make sure that the unit is disconnected from the power supply.

Should the unit, or a part of it, be decommissioned, the parts liable to cause any hazard must be rendered harmless.

Qualified personnel must dismantle and demolish the unit.

1.3 SERVICE RULES

The operating rules described in this manual are an integral part of the unit supply.

These rules are also intended for operators previously trained specifically to operate this type of unit and contain all the necessary and important information for operating safety and optimal use of the unit.

Rushed and incomplete training leads to improvisation, which is the cause of many accidents.

Read carefully and comply strictly with the following recommendations before starting work:



**ATTENZIONE
WARNING**

The first start up must be performed exclusively by qualified personnel authorised by the manufacturer;

- When installing or servicing the unit, the rules indicated in this manual must be complied with, together with those on board the unit and, in any case, all necessary precautions must be taken;
- Potential accidents to persons and property can be prevented by following these technical instructions with reference to the Machinery Directive 2006/42/EC and subsequent amendments. In all cases, always comply with the national safety regulations;
- Do not remove or damage the safety devices, labels and notices, especially those imposed by law and replace them if no longer legible.

The machine-directive 2006/42/EC provides the following definitions:

DANGEROUS ZONE: *any zone within and/or close to a machine in which the presence of an exposed person constitutes a risk to the health and safety of that person.*

EXPOSED PERSON: *any person who is completely or partially in a hazardous zone.*

OPERATOR: *the person or persons assigned to installing, operating, regulating, performing maintenance on, cleaning, repairing and transporting the machine.*



**AVVERTENZA
CAUTION**

All operators must comply with the accident-prevention regulations (international or of the destination country of the unit) in order to avoid possible accidents.

Please note that the European Union has issued certain Directives regarding health and safety of workers, including: Directive 89/391/EEC, 89/686/EEC, 89/654/EEC, 89/655/EEC, 89/656/EEC, 86/188/EEC, 92/58/EEC and 92/57/EEC, which every employer is obliged to comply with and enforce.

The units have been designed and built according to the current state-of-the-art and technical rules in force.

Applicable laws, provisions, regulations, decrees and directives for such machinery have been complied with.

The materials used and the parts of equipment, as well as production procedures, quality and control assurance comply with the highest standards of safety and reliability.

Unit performance, continuous operation and durability are maintained by using the above-mentioned materials and parts for the purposes specified in this user manual, handling them with due care and performing thorough maintenance and up-to-standard service.

1.4 INTENDED USE

RER units are ductable dehumidifiers with heat recovery unit for horizontal (typical false-ceiling) installation, while REV units are for vertical (typical in wall) installation: both RER and REV are conceived to function combined with radiant systems. RER and REV units can dehumidify, cool, and heat the air and they also allow air renewal with heat recovery: exhaust air is discharged and fresh air is supplied to the internal ambient.

Its use is recommended within the operating limits indicated in this manual.



**PERICOLO
DANGER**

Place the unit where there are no explosion, corrosion or fire dangers, either in vibrating areas or in the presence of electro-magnetic fields. It is also prohibited to operate in any way other than that stipulated or disregard required safety operations.

1.5 RESIDUAL RISK AREAS



**PERICOLO
DANGER**

In some areas of the unit there are residual risks that could not be eliminated during the design phase or delimited with guards due to the particular functionality of the unit. Every operator must be aware of the residual risks present in this unit and exercise extreme caution to avoid any accidents.

- risk of short circuit and fire caused by short circuit
- risk of explosion due to the presence of pressurised circuits and risk of pollution due to the presence of refrigerant in the circuit
- risk of burns due to the presence of very hot pipes
- risk of shearing

1.6 INTERVENTION AND MAINTENANCE

It is important to remember that the user manual can never replace adequate user experience. This manual represents a reminder of the main activities to be performed by operators who have received specific training, for example by attending training courses held by the manufacturer, with reference to particular maintenance operations.

Carefully read the following recommendations:

- A constant and pre-scheduled maintenance can grant the safety working of the unit. If there are some necessary maintenance interventions, do not delay them and make reference only to qualified operators and original spare-parts;
- Plan each intervention carefully;
- Operators' working space should be clean and free, in order to grant the necessary movements without dangers;
- Operators should avoid clumsy operations, in uncomfortable conditions which can compromise their balance.
- Operators must pay attention to the risk of clothing and/or hair being caught or entangled in moving parts. A cap should be worn to keep long hair in place.
- The use of chains, bracelets and rings can also be dangerous.
- Even the use of necklaces, bracelets and rings can be a danger; The working place should be correctly lighted; insufficient or excessive lights can be a danger;
- Wait about 10 minutes after switching the unit off before performing any maintenance in order to prevent burns;



**PERICOLO
DANGER**

Do not repair high pressure pipes with welds; Liquid pressure on the refrigerant circuits and electrical components presence can be dangerous during installation and maintenance operations;

- Reduce as much as possible the time of open for the refrigerant circuit: Oil exposition to air causes the absorb of high quantity of humidity and this leads to the creation of weak acids;
- Only qualified personnel may perform work on the unit;
- Before performing any kind of work or maintenance on the unit, make sure it has been disconnected from the power supply;
- Make sure that safety devices work properly and that there are no doubts about their functioning; if not do not start the unit;
- Use only tools prescribed by the unit manufacturer. In order to avoid personal injury, do not use worn or damaged, low quality or improvised tools;



Once the unit has been cleaned, the operator must check that there are no worn or damaged parts or parts that are not firmly secured; where these are found, request the intervention of the maintenance technician;

- Always keep the area in which the unit is kept clean and tidy. Oil and grease stains, broken tools or broken pieces are harmful to persons as they can cause slips or falls;
- It is prohibited to use flammable fluids to clean the unit.

Do not use diesel, petroleum or solvents to clean the unit as they leave an oily film that encourages dust to settle, while solvents (even if weak) damage the paintwork and encourage the formation of rust. If a jet of water penetrates the electrical equipment, the contacts oxidise and the unit may malfunction. Therefore, do not use jets of water or steam on the sensors, connectors or any electrical part.

Make sure that the pressurised pipes, or other components subject to wear, are intact. Also make sure there are no leaking fluids or hazardous substances.

Should there be a leak, the operator must not restart the unit before having resolved the problem.

1.7 GENERAL SAFETY RULES

1.7.1 Wearing protective clothing

Operators should wear personal protective equipment such as gloves, helmet, safety glasses, safety footwear and cap for protection against noise.



1.7.2 Fire extinguisher and first aid

Place a first aid box and a fire extinguisher near the unit.

Periodically check that the fire extinguishers are loaded and all operators know how to use them.

If a fire breaks out, use the fire extinguisher according to the relative regulations in force and contact the fire brigade.

Periodically check that the first aid kit is complete.

Make sure the emergency telephone numbers are readily available and nearby.

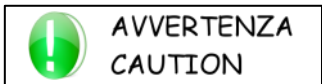

The owner of the property where the unit is installed is responsible for providing any fire extinguishers and a first aid kit.

1.7.3 Suggestions for advices and maintenance

Place a notice with the wording: "MAINTENANCE IN PROGRESS" on all

Carefully check the unit according to the list of operations specified in this



sides of the unit.
manual.

1.7.4 Safety data plate



Generic danger



Hazard: moving mechanical parts



Shearing risk



Electric voltage hazard



Risk of burns

2 PRODUCT DESCRIPTION

RER and **REV** units are conceived for a use in residential and commercial ambiances, with high latent load and for a 24h/day functioning.

They are suitable in combination with cooling radiant systems: underfloor, walls, ceiling.

RER/REV units combine top technical solutions with a pleasant appearance and, if supplied with water at 15°C, can dehumidify the ambient air without modifying its temperature or it could cool the air.

Neutral air is possible thanks to the presence of two exchangers, used to pre-cool the air and post-cool it after dehumidification process.

Cooled air is possible thanks to the presence of a plate exchanger which removes the thermal load from the ambient through the water of the radiant system.

The units are conceived to be ducted with flexible pipes or rigid ducts.

The use of electronic radial fans with brushless motor and inverter integrated, ensure high static pressure and reduced electrical consumptions.

The use of exclusive high-quality refrigerant, hydraulic, gas and electrical components make **RER/REV** dehumidifiers the state-of-art in terms of efficiency, reliability and sound emitted level. High-efficiency heat recovery unit ensure over 90% efficiency.

2.1 SERIES

There are 24 available models, classified according to the dehumidification capacity (15, 20, 35...) and to the version (W-A-I):

RER 015 W	RER 015 A	RER 015 I
RER 020 W	RER 020 A	RER 020 I
RER 035 W	RER 035 A	RER 035 I
RER 050 W	RER 050 A	RER 050 I
RER 100 W	RER 100 A	RER 100 I
REV 020 W	REV 020 A	REV 020 I
REV 035 W	REV 035 A	REV 035 I
REV 050 W	REV 050 A	REV 050 I

The **RER/REV _ W** units do not have a compressor and function with chilled water in summer or heated water in winter. Dehumidification, cooling or heating, are performed thanks to a water coil provided with 3-ways valve.

In summer, with cooling/dehumidification request, and in winter, with heating request, the water valve will be open and the supply air will be treated. If there is no water supply, the unit will function in ventilation mode.

The **RER/REV _ A** units have a compressor and 4 heat exchange coils, in particular: water pre-cooling, evaporating, condensing, water post-cooling. These units allow summer dehumidification with neutral air and heating in winter.

In summer unit operate differently depending on water temperature:

- Below 9°C → unit continues to work, but the compressor will be turned off and the air supply will be treated only with water.
- Between 12 and 15°C → air is dehumidified and cooled;
- 15°C → air is dehumidified and neutral (supply air at the same temperature of inlet air)
- Above 15°C → no dehumidification capacity;

In winter, the compressor will always be turned off and the air will be heated through radiant system water.

If water will not be supplied, the unit will continue to function, but it can't perform dehumidification in summer and heating in winter.

The **RER/REV_I** units have a compressor, a plate exchanger and 3 heat exchange coils, in particular: water pre-cooling, evaporating and condensing. Units RER/REV_I in summer can dehumidify supplying neutral or cooled air, while in winter it heats air.

In summer unit operate differently depending on water temperature:

- Below 9°C → unit continue to work, but the compressor will be turned off and the air supply will be treated only with water.
- Between 12 and 18°C → air will be dehumidified and cooled;
- Greater than 32°C → compressor will be turned off and air will be heated with the water coil.

In winter the compressor will always be turned off and the air will be heated through water.

The RER/REV_I unit cannot operate without water and will block in summer. Unblocking has to be done in manual mode, by resetting the alarm which appears on the display.

Without water, the compressor will give high pressure or serious alarm. A non-serious alarm will automatically reset, while the serious one can be reset only in manual mode. If 3 non-serious alarms occur in 30 minutes, this will turn to a serious alarm; but, if after 30 minutes there are no more the conditions to activate the non-serious alarm, it will automatically reset.

During the unit stoppage for water lack, the compressor will be turned off, an alarm will appear, the air will not be treated and the unit could function only in recirculation/fresh air mode. In winter, without water, the unit will not stop, but it will lose the capacity of heating.

All **A-I-W** versions can recirculate the ambient air regardless of the season or the presence of the radiant system water.

2.2 AIR FLUXES

RER units have 5 connections for air ducts:

1. Supply in ambient (rooms and living)
2. Return from ambient (normally the corridor of RER) for recirculation within the house
3. Exhaust air extraction (from “dirty” ambient such as bathrooms, kitchens, laundry...)
4. Fresh air inlet
5. Exhaust expulsion outside

Air flows vary according to the model:

	RER 015	RER/REV 020	RER/REV 035	RER/REV 050	RER 100
Supply in ambient	160 m ³ /h	260 m ³ /h	380 m ³ /h	520 m ³ /h	1000 m ³ /h
Return from ambient	160 m ³ /h	260 m ³ /h	380 m ³ /h	520 m ³ /h	1000 m ³ /h
Exhaust air ejection	80 m ³ /h	130 m ³ /h	190 m ³ /h	260 m ³ /h	500 m ³ /h
Fresh air inlet	80 m ³ /h	130 m ³ /h	190 m ³ /h	260 m ³ /h	500 m ³ /h
Exhaust air expulsion	80 m ³ /h	130 m ³ /h	190 m ³ /h	260 m ³ /h	500 m ³ /h

The units can function in 4 modes, which will be automatically managed according to the values of desired temperature and humidity and according to the level of fresh air set:

1. The temperature and humidity in the room are correct and the renewal is set to zero: the unit is completely stopped
2. The temperature and humidity in the room are not correct and the renewal is set to zero: the unit is treating the air or it is heating or cooling and/or dehumidifying; the unit is in recirculation mode only
3. The temperature and humidity in the room are correct and the renewal is set to a value other than zero: the unit is renewing the air that is the exhaust air is expelled and the renewal air is supplied to the ambient; the unit is in recirculation mode only
4. The temperature and humidity in the room are not correct and the renewal is set to a value other than zero: the unit is treating and renewing the air; the unit is in recirculation + renewal mode

The following pictures show the air flows for each mode of operation and each size of unit.

- When recirculation is active (heating or cooling and/or dehumidification active), the supply in ambient will always be maximum
- The air flows that pass through the recovery system are always the same and they are balanced
- The renewal is adjustable on 5 levels, from 1 to 5. The number indicates the percentage of renewal, for example if set at 2 out 5, it corresponds to 40% of the maximum.

Arrows meaning

- Red Expulsion
- Blue Renewal
- Green Recirculation

2.2.1 **RER 015 – only recirculation mode**

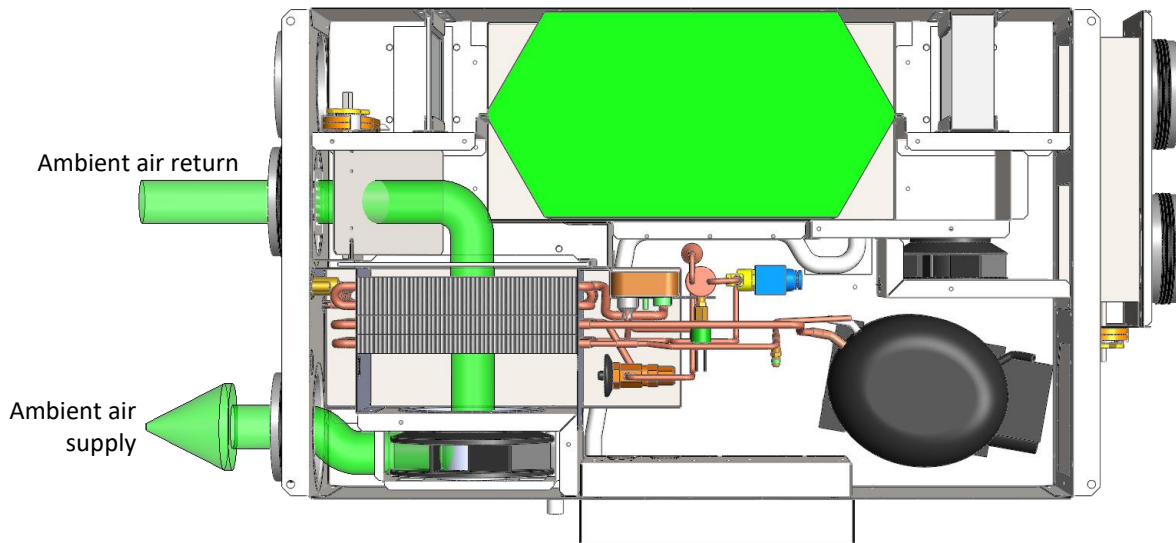

2.2.2 **RER 015 – only renewal mode**

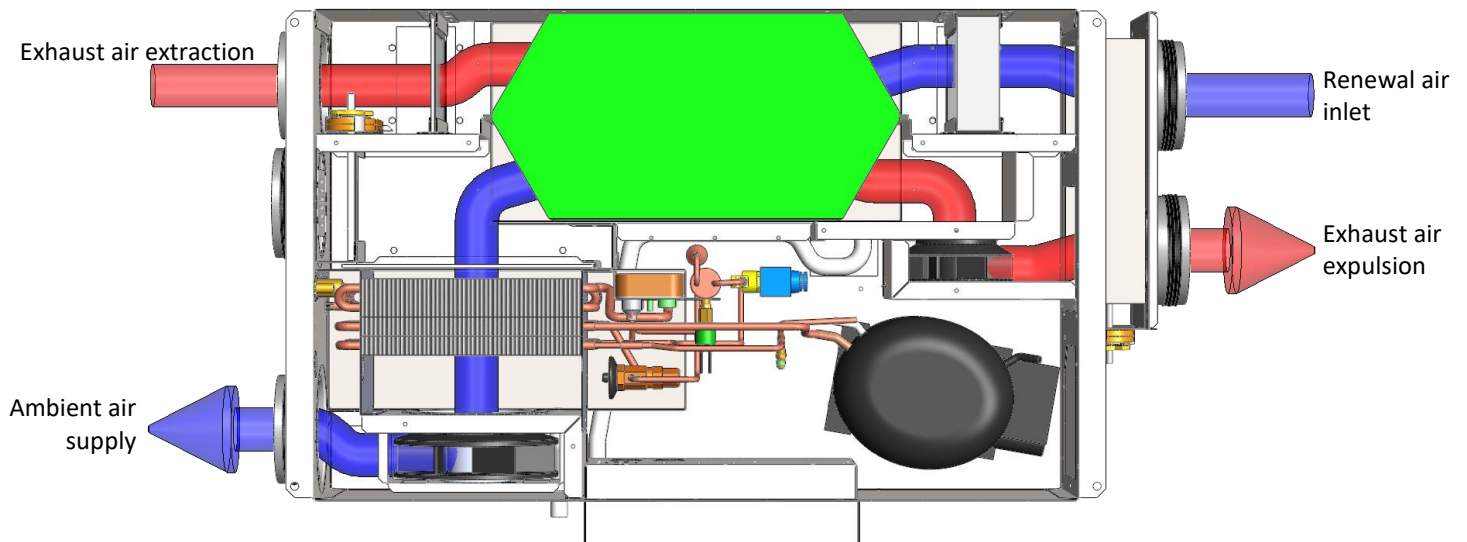

2.2.3 **RER 015 – recirculation + renewal**

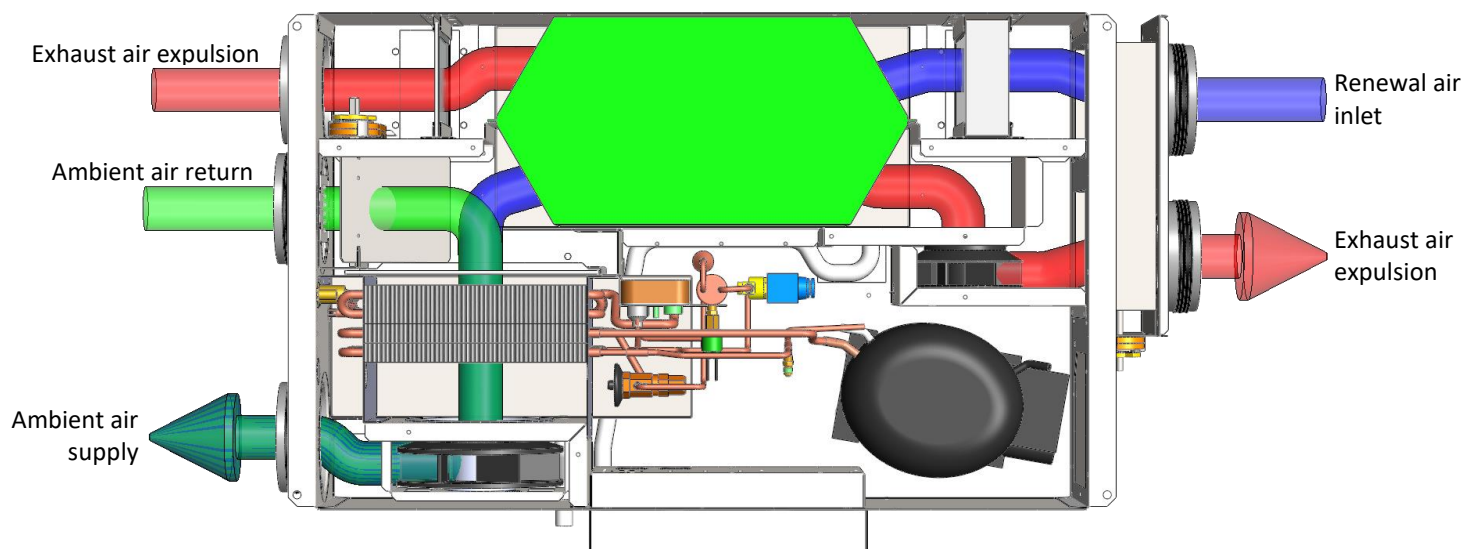

2.2.4 RER 020 and RER 035 – only recirculation mode

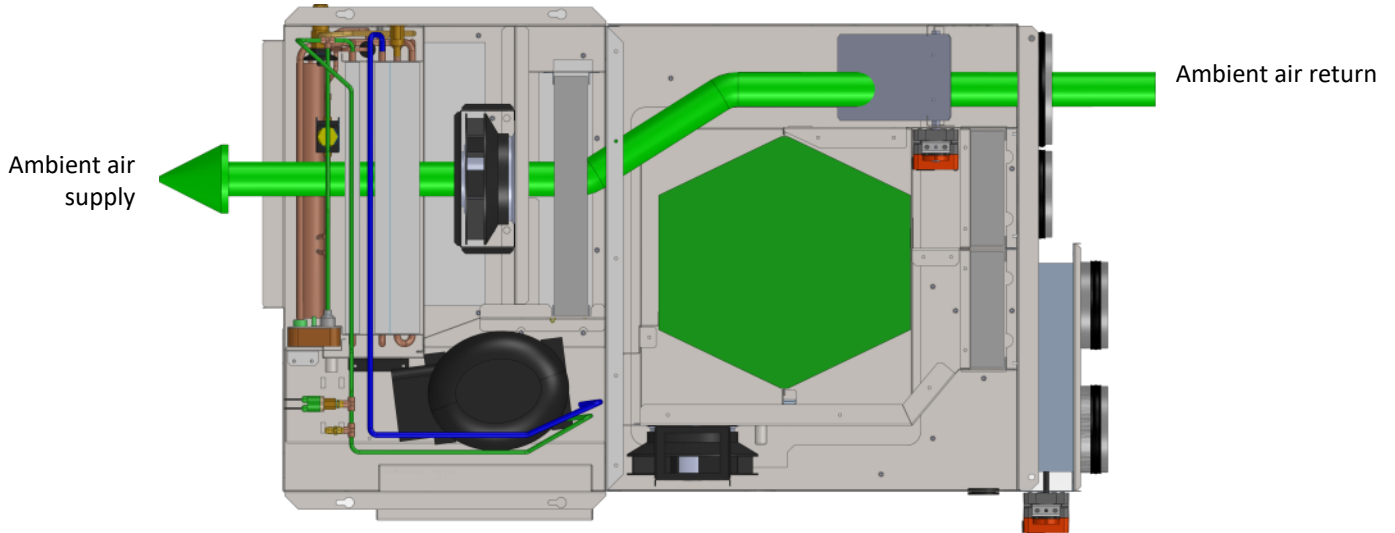

2.2.5 RER 020 and RER 035 – only renewal mode

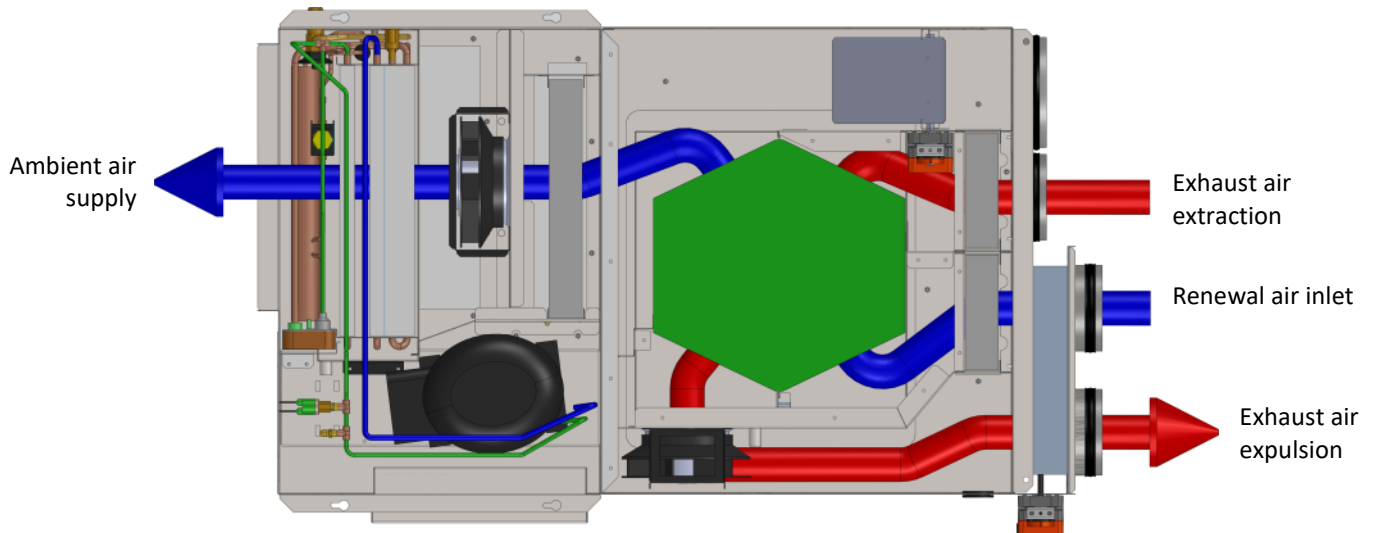

2.2.6 RER 020 and RER 035 – recirculation + renewal

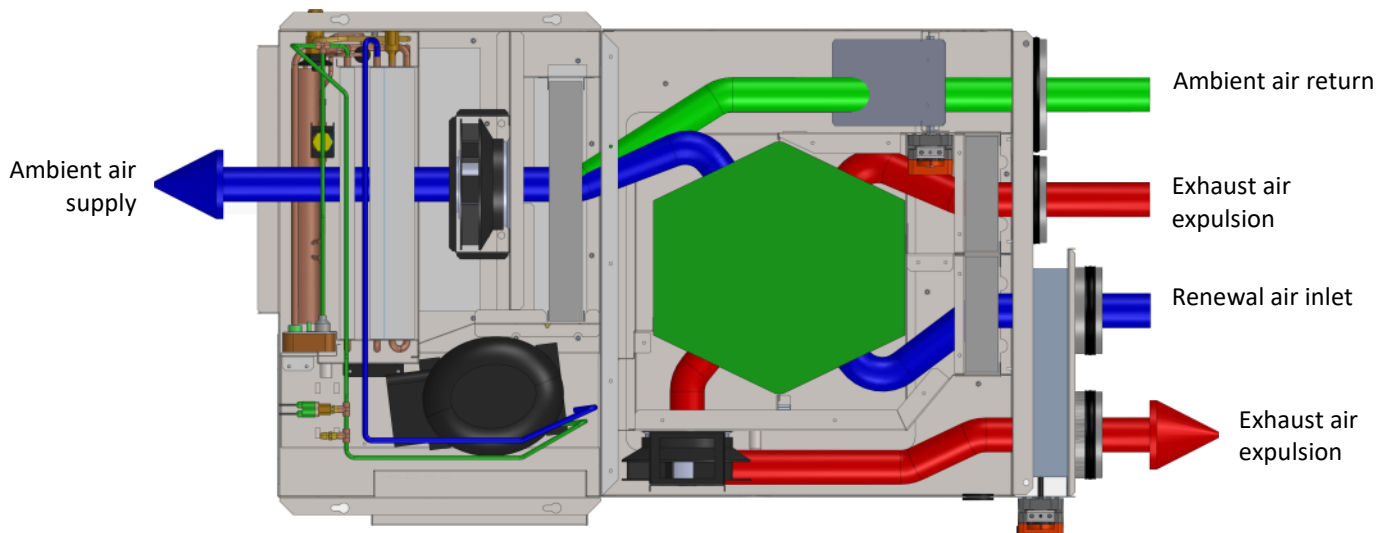

2.2.7 RER 050 – only recirculation mode

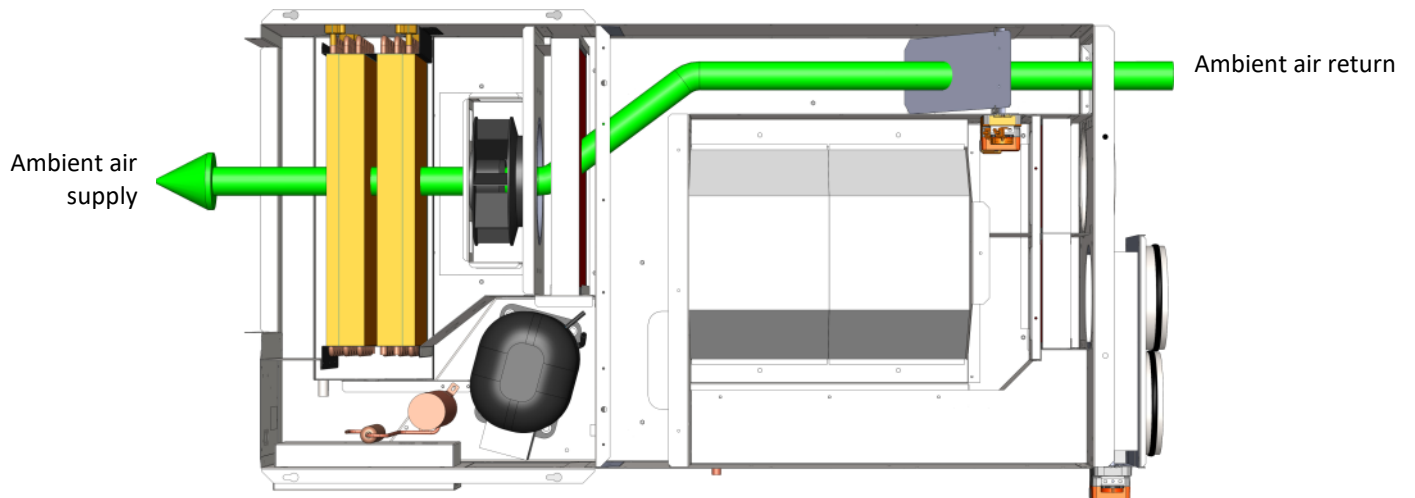

2.2.8 RER 050 – only renewal mode

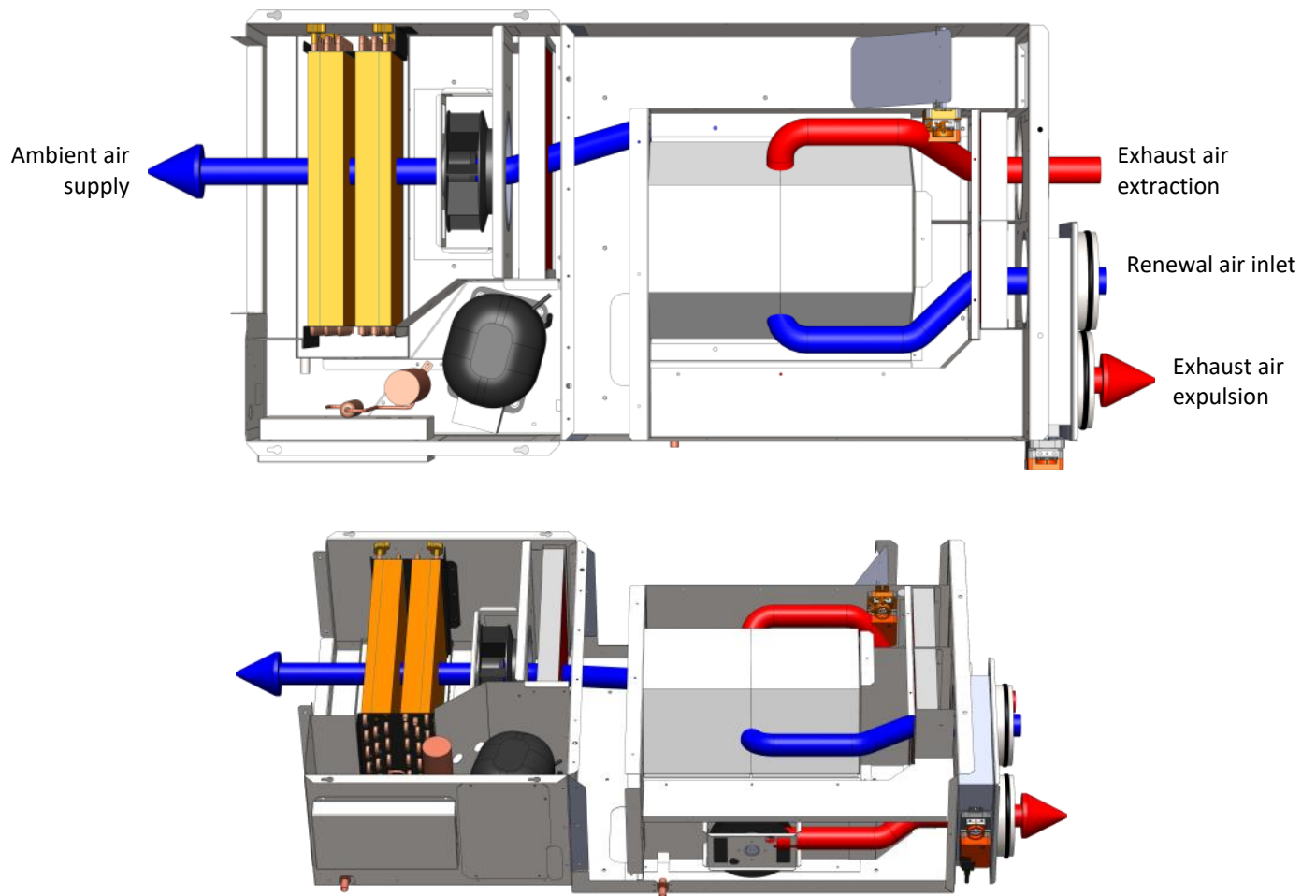

2.2.9 RER 050 – recirculation + renewal

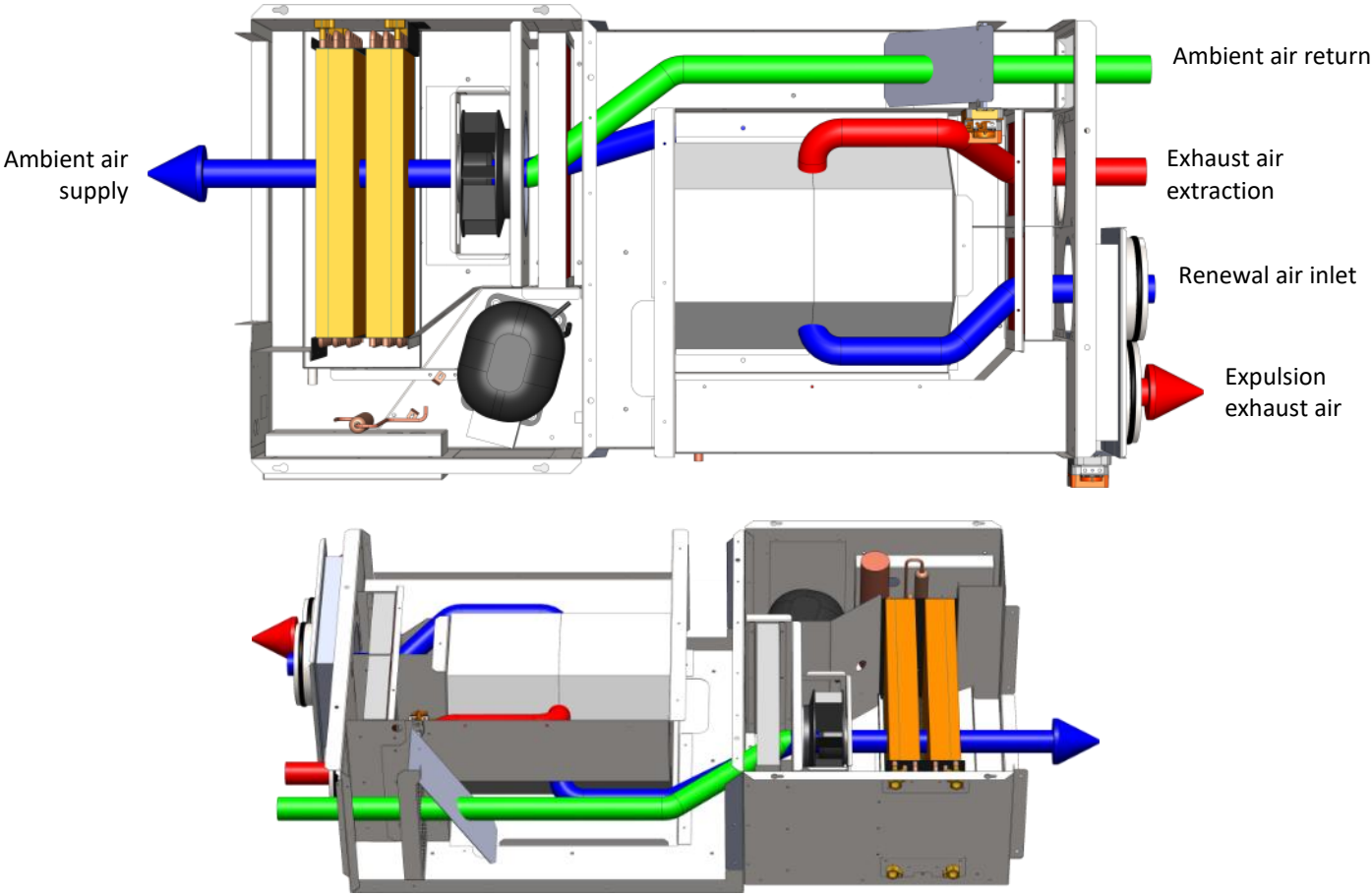

2.2.10 RER 100 – only recirculation mode

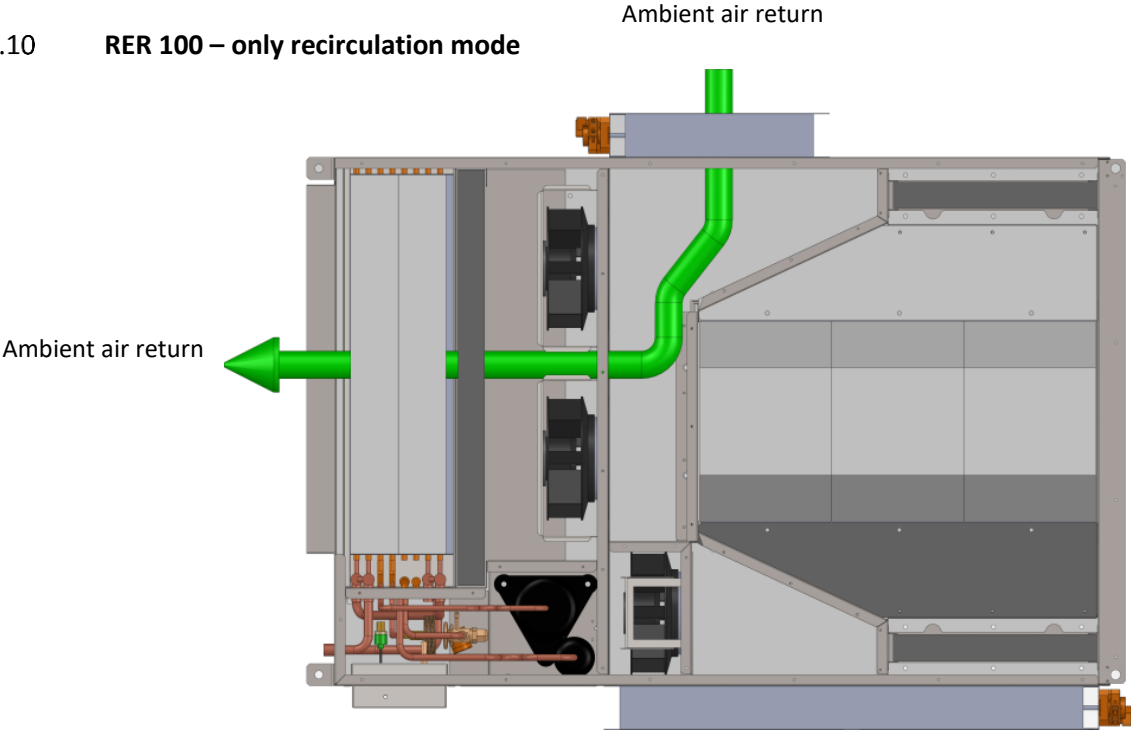

2.2.11 **RER 100 – only renewal mode**

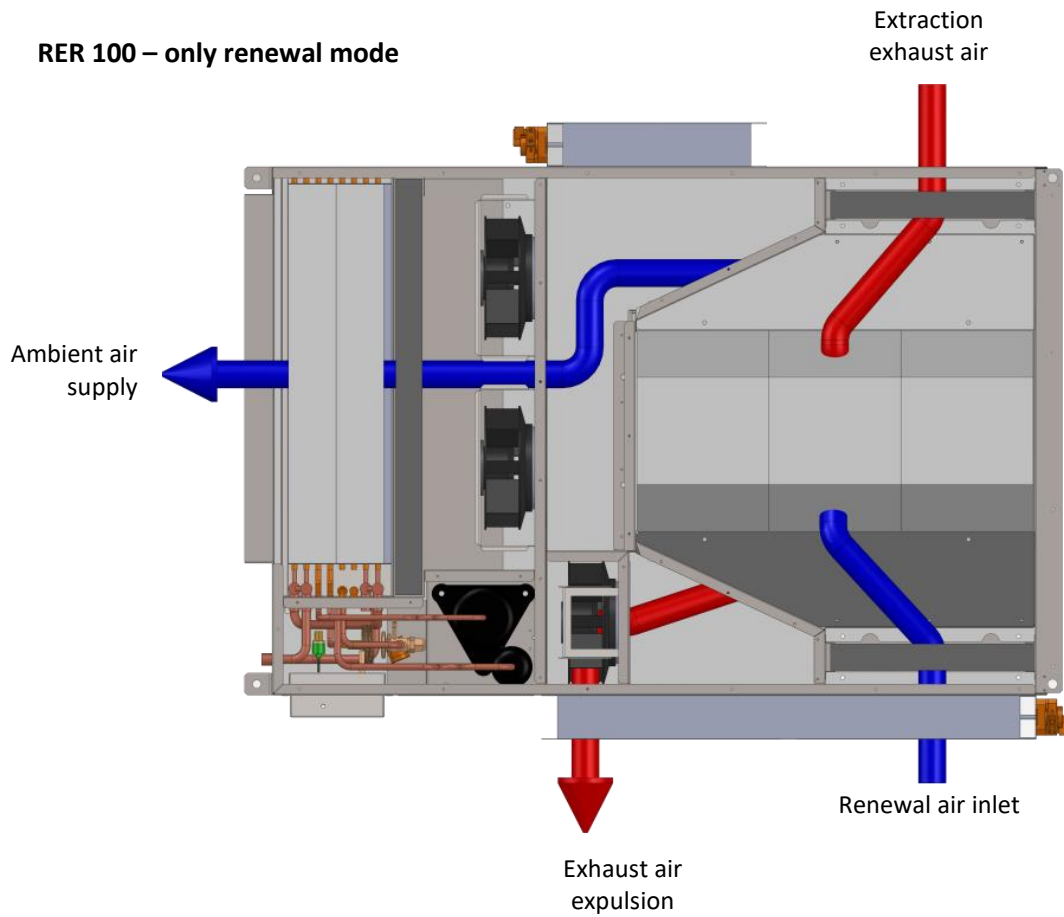

2.2.12 **RER 100 – recirculation + renewal**

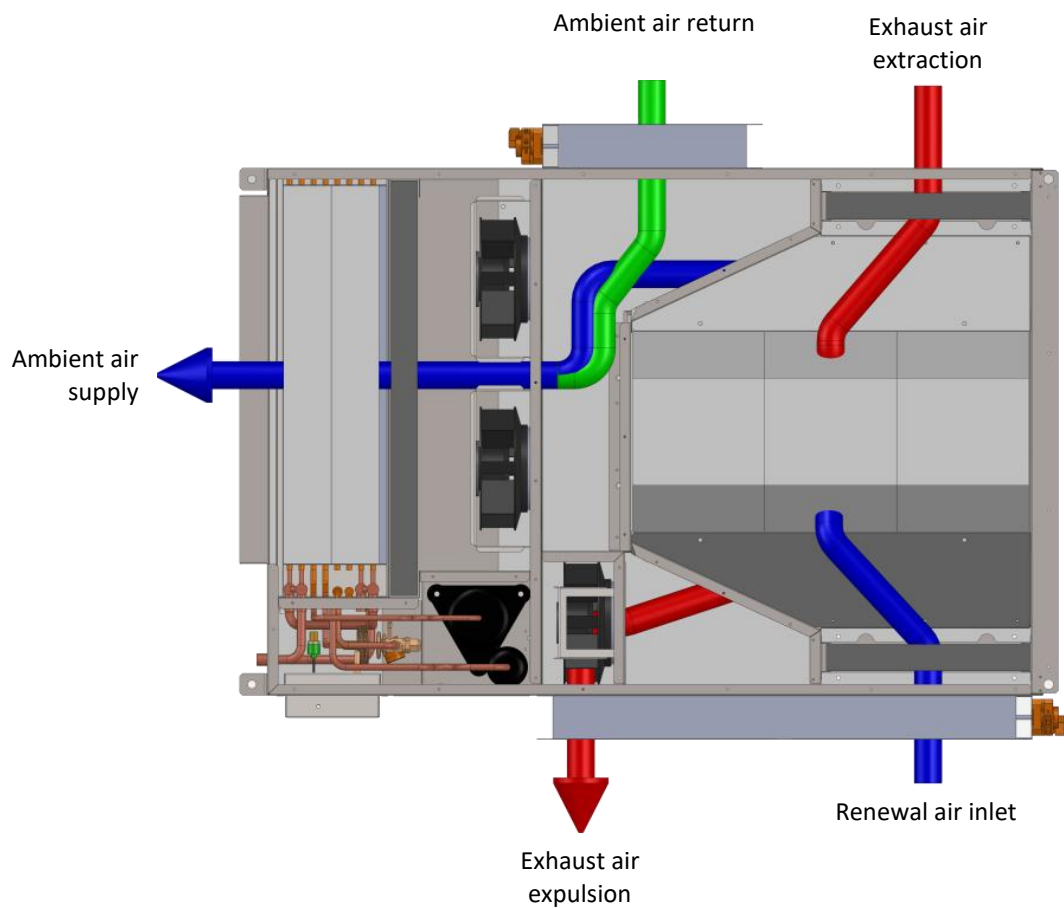

2.2.13 REV 020 and 035 – recirculation only

Ambient air supply

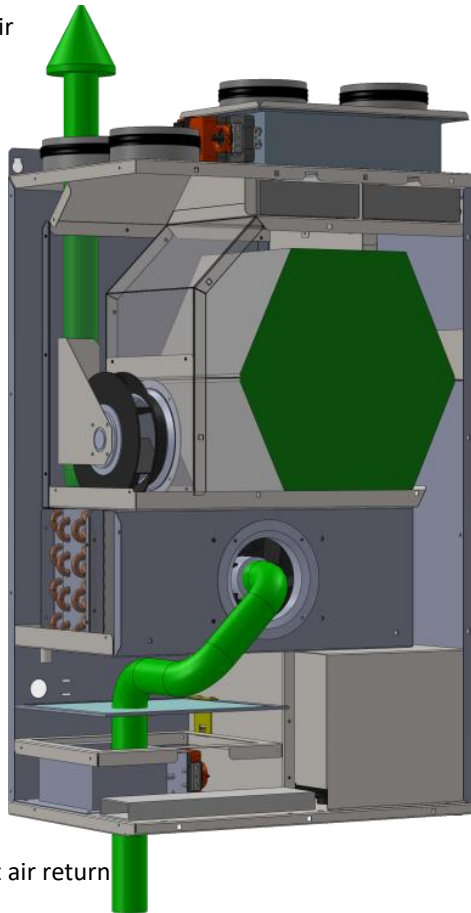

Ambient air return

2.2.14 REV 020 and 035 – renewal only

Exhaust air expulsion

Ambient air supply

Renewal air inlet

Exhaust air extraction

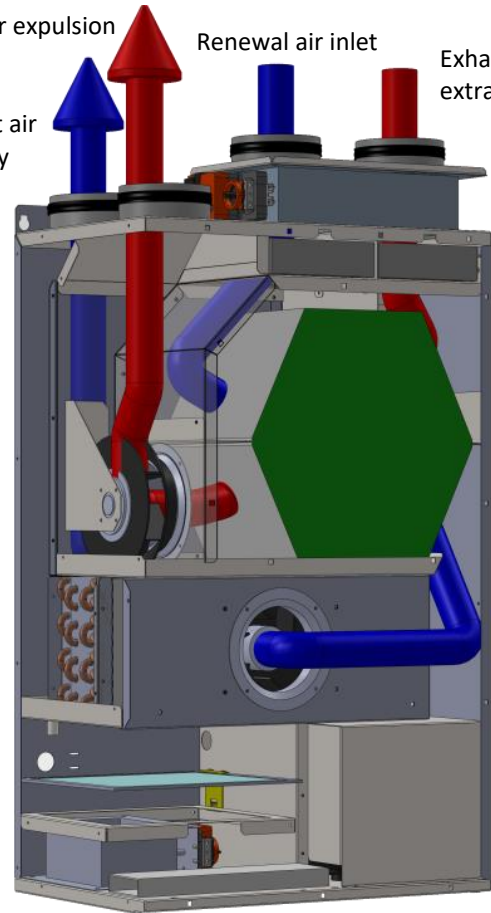

2.2.15 REV 020 and 035 – recirculation + renewal

Exhaust air expulsion

Ambient air supply

Renewal air inlet

Exhaust air extraction

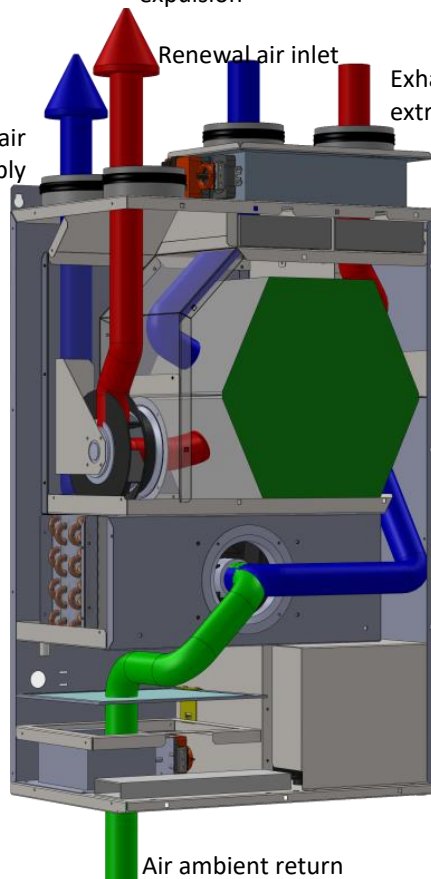

Air ambient return

2.2.16 **REV 050 – recirculation only**

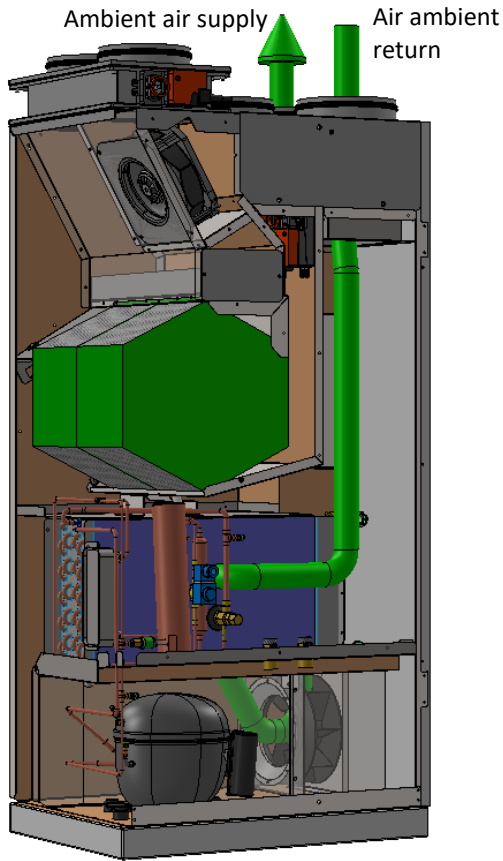

2.2.17 **REV 050 – renewal only**

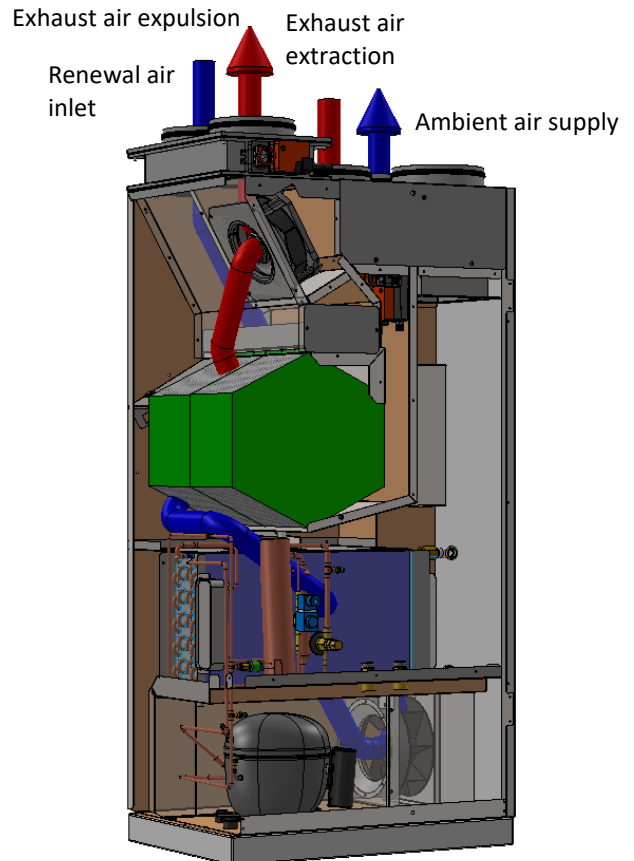

2.2.18 **REV 050 – recirculation + renewal**

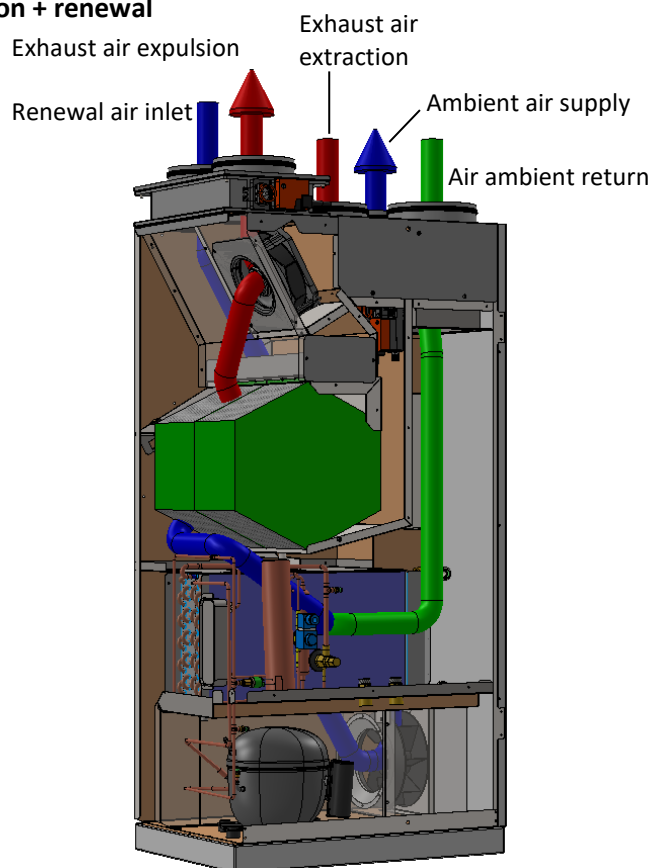

2.3 REV UNIT POSSIBLE INSTALLATIONS

2.3.1 Visible internal installation (REV 020 and REV 035)



On the left picture, the unit is installed on sight and can be hidden by a dedicated cover; it is fundamental to leave a passage for recirculation air (please refer to the previous chapters for air fluxes).

On the right picture, the unit is installed on sight within a bathroom or a laundry: in this case, there is a back plenum which allows to duct recirculation air (avoiding to spread within the house bath/laundry air).

2.3.2 Recessed internal installation (only REV 020)

In this case the unit is installed within a carter, predisposed during the building construction within a wall of appropriate thickness; then, the unit is fixed within the carter, which normally leaves an open space on the lower part for recirculation air, and the necessary space on the upper part, in order to realize the ducts.



2.3.3 Recessed external installation (only REV 020)

In this case, a carter is installed during the building construction within an outdoor wall of appropriate thickness; then, the unit is fixed within the carter, which normally leaves the necessary spaces in order to realize the ducts. A cover panel is supplied with the carter. (Complete with 2 grilles, for fresh air suction and exhaust air expulsion).



2.4 STRUCTURE

The unit is created with an exclusive design that gives the assembly a pleasant appearance as well as ensuring complete inaccessibility, when the machine is closed. This aspect combined with the wide use of sound-absorbing material inside the compartment reduces the sound power level emitted to exceptionally low levels.

Most of the panels can be removed to allow complete access to the unit. For ordinary maintenance, RER units are accessible from below, REV units from the front

All screws and fastening systems are made of non-oxidizable materials and of carbon steels with surface passivation treatment. The layout of the components guarantees easy access and optimal weight distribution on the base of the unit.

2.5 OPERATIONAL AND FUNCTIONAL LIMITS

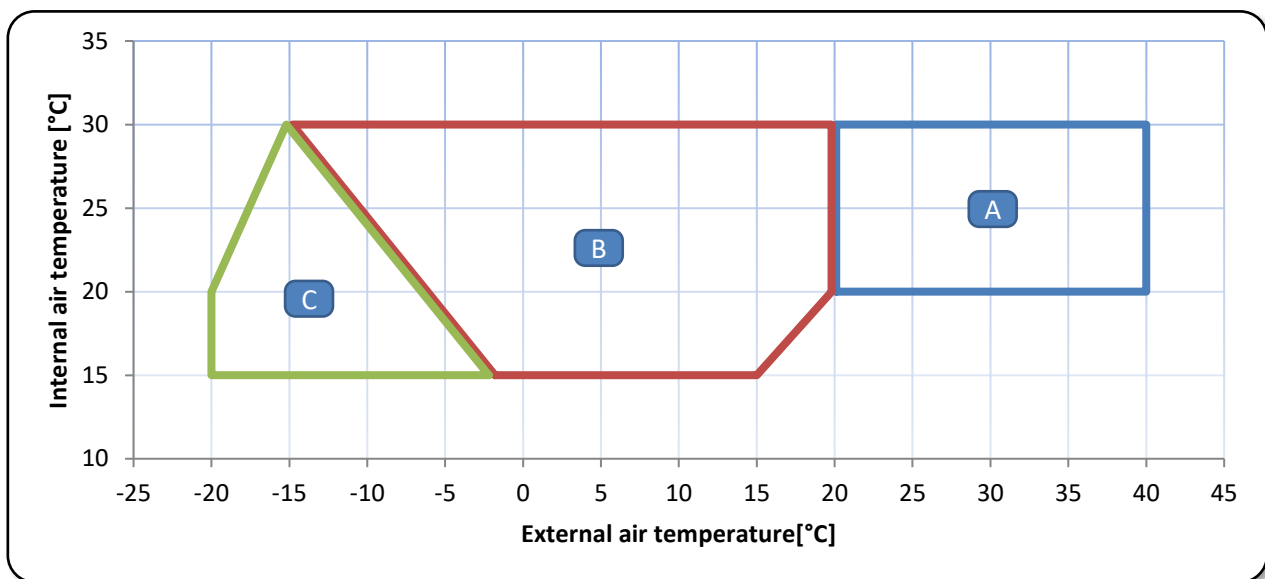

In this diagram we found the operating temperature limits of the unit:

- A SUMMER
- B WINTER
- C Extension of winter operating limits with heat recovery unit automatic defrost [optional].

The functioning humidity limits are 40 – 90 % U.R.



ATTENZIONE
WARNING

The temperature and humidity conditions at the place of installation shall comply with the limits set out in this paragraph. Non-compliance with these limits may cause damage to the unit.

2.6 OPTIONS AND FUNCTIONS

	RER					REV		
	015	020	035	050	100	020	035	050
<i>Electronic fans with brushless motor and integrated inverter</i>	SERIES					SERIES		
<i>Regulation graphic display with temperature and humidity probes and 2 m of connecting shielded cable</i>	SERIES					SERIES		
<i>5 speeds regulation for fresh air</i>	SERIES					SERIES		
<i>Dirty filter timed signal</i>	SERIES					SERIES		
<i>Detailed anomaly signal</i>	SERIES					SERIES		
<i>Turbo mode</i>	SERIE					SERIE		
<i>Clock card – time scheduling</i>	SERIE					SERIE		
<i>Water anti-frost function</i>	SERIE					SERIE		
<i>Kitchen extractor hood function</i>	SERIE					SERIE		
<i>Automatic defrost of the dehumidifier</i>	SERIE					SERIE		
<i>On/off control for supply air temperature</i>	SERIE					SERIE		
<i>Adjustable control for supply air temperature</i>	OPZIONE					OPZIONE		
<i>Adjustable control kit for supply air temperature</i>	OPZIONE					OPZIONE		
<i>RS485 Modbus serial card</i>	SERIE					SERIE		
<i>Free cooling</i>	OPZIONE					OPZIONE		
<i>Automatic defrost of the heat recovery</i>	OPZIONE					OPZIONE		
<i>Connecting shielded cable (display of 5, 10 or 20 m)</i>	OPZIONE					OPZIONE		
<i>Temperature and humidity probes mounted on board</i>	OPZIONE					OPZIONE		
<i>CO₂ probe</i>	OPZIONE					OPZIONE		
<i>Motorised dampers for ambient dew point control</i>	OPZIONE					OPZIONE		
<i>High efficiency air filters set</i>	OPZIONE					OPZIONE		
<i>Supply plenum</i>	-	OPZIONE				-	-	-
<i>Recirculation plenum</i>	-		OPZIONE			OPZIONE		-
<i>Kit for recirculation duct</i>	-	-	-	-	-	OPZIONE		-
<i>Extraction flange</i>	-				OPZIONE	-	-	-
<i>Flange for canalization</i>	-				OPZIONE	-	-	-
<i>Silent version with insulation of the compressor vain</i>	OPZIONE					OPZIONE		
<i>Second display</i>	OPZIONE					OPZIONE		
<i>Display mounted on board</i>	-	-	-	-	-	OPZIONE		
<i>Wooden cage</i>	OPZIONE					OPZIONE		

2.6.1 Turbo mode

TURBO mode is particularly useful to eliminate unpleasant odours as quickly as possible. In fact, it activates fresh air exchange at the maximum speed for 10 minutes (the time can be changed from the instaleer menu). To activate TURBO mode, simply press OK on the advanced control display for 3 seconds. After the 10 minutes, the unit will automatically go back to the previous operating conditions.

2.6.2 Water anti-frost function

The unit is equipped with a special probe, placed before the water coils, which checks the air temperature and allows the unit to avoid freezing the water inside the coils if the outside air is particularly cold.

2.6.3 Kitchen extractor hood function

During the period in which this function is active, the unit will release more air than it extracts, to compensate for the effect of an extractor hood. The hood function can be activated using the configurable inputs.

2.6.4 Automatic defrost of the dehumidifier

If the unit is equipped with a compressor, the evaporating coil will be defrosted cyclically to allow optimal operation.

2.6.5 On/off control for supply air temperature

The function allows the unit to monitor the air that is introduced into the environment and if it does not respect the limits, which can be modified in the installer menu, the unit circulates water inside the water coil to dilute the air.

2.6.6 Adjustable control for supply air temperature

A supply temperature probe, a transformer for the valve and a 0 – 10 V modulating output are mounted on the unit. When the machine is set in heating mode, so in winter mode, it allows precise adjustment of the supply air temperature.

The request has to be communicated when the order is placed; this option is not compatible with free cooling.

2.6.7 Adjustable control kit for supply air temperature

A supply temperature probe, a transformer for the valve, a 0 – 10 V modulating output, the water valve and the relative servomotor are mounted on the unit. When the machine is set in heating mode, so in winter mode, it allows precise adjustment of the supply air temperature.

The request has to be communicated when the order is placed; this option is not compatible with free cooling

2.6.8 RS485 Modbus serial card

The connection with bus RS485 is available for remote supervision or domotic management.

More information available on request.

2.6.9 Free cooling

When in summer the external conditions are more comfortable than indoor conditions, the unit automatically activates the external air inlet without heat recovery with expulsion air. The indoor air temperature, further which the free cooling is activated, is the one set as desired temperature. This option includes also the free heating function.

The request has to be communicated when the order is placed; this option is not compatible with supply air temperature control.

2.6.10 Automatic defrost of the heat recovery

A temperature probe placed in exhaust air expulsion together with a software function, allows the installation of the unit even where the outside temperature is really cold, by proceeding with a defrost of the heat recovery each time it is necessary, avoiding the block of the thermal exchange and the introduction in the house of cold air.

The request has to be communicated when the order is placed.

2.6.11 Connecting shielded cable (display of 5, 10 or 20 m)

A double-wires cable, from 5 up to 20 meters, is available for the connection between the unit and the on-wall display.

2.6.12 Temperature and humidity probes mounted on board

A temperature probe and a humidity probe in ambient air intake are mounted on the unit. This allows positioning of the wall display in a technical room and setting of the temperature and humidity reading from the machine and not from the display.

The request has to be communicated when the order is placed.

2.6.13 CO₂ probe

The CO₂ probe is particularly useful for installations in public places such as offices or meeting rooms where the values of carbon dioxide are subject to wide and sudden variations. In this case, the air renewal will always be aligned with the effective needs of the indoor ambient. The probe is supplied separately and must be installed in the environment.

The CO₂ (carbon dioxide) probe detects the quantity of carbon dioxide present in the environment.

The request has to be communicated when the order is placed.

2.6.14 Motorised dampers for ambient dew point control

It consists on a double damper which intercepts the outdoor air and avoids unwanted air passages when the unit is OFF or when the air exchange is not necessary. Moreover, in highly humid summer periods, the dampers allow a better control of the indoor humidity, avoiding the condensation on the floor, due to the introduction of too much humid air from the outside.

The request has to be communicated when the order is placed.

2.6.15 High efficiency air filters set

It consists of a set of more efficient filters than the one present in the unit: this ensure a major cleanness of the air and helps in keeping outdoor the micro-parcels coming from outside.

2.6.16 Supply plenum

A supply plenum allows to duct the supply with flexible pipes: this is available only for RER models.

More information available on request.

2.6.17 **Recirculation plenum**

For the RER units, a recovery plenum is provided which is used to channel the room air intake for recirculation with spiral hoses. For the REV units a plenum is provided to be installed between the wall and the unit which allows channelling of the intake of ambient air for recirculation upwards; this accessory is essential where the unit is installed in bathrooms and in other rooms where unpleasant odours may form. It is only available for REV units.

More information available on request.

2.6.18 **Kit for recirculation duct**

It consists of a nozzle to be fixed on the lower part of the unit to duct the ambient air extraction for the recirculation.

It is available only for REV units.

2.6.19 **Extraction flange**

It consists of a frame inserted in the extraction of the dehumidifier which allows easier connection to the duct.

2.6.20 **Flange for canalization**

It consists of a flange that facilitates the connection of the unit to rigid channels for air distribution.

2.6.21 **Silent version with insulation of the compressor vain**

There is a sound-absorbent material in all the compressor vain: this allows to reduce the noise produced by the unit when it is working; it is available for all the sizes A (isothermal) and I (with cold integration).

The request has to be communicated when the order is placed.

2.6.22 **Second display**

An additional display is provided to be connected to the electronic board in order to control the machine from two different points of the house.

2.6.23 **Display mounted on board**

The display is fixed on the frontal panel of the unit, already connected to the electrical board: with this option, there is no need to install the display on the wall so, no need for connecting cable. It is available only for REV unit.

The request has to be communicated when the order is placed.

3 REFRIGERANT AND HYDRAULIC CIRCUITS

3.1 FUNCTIONAL SCHEMES

Model W (hydraulic)

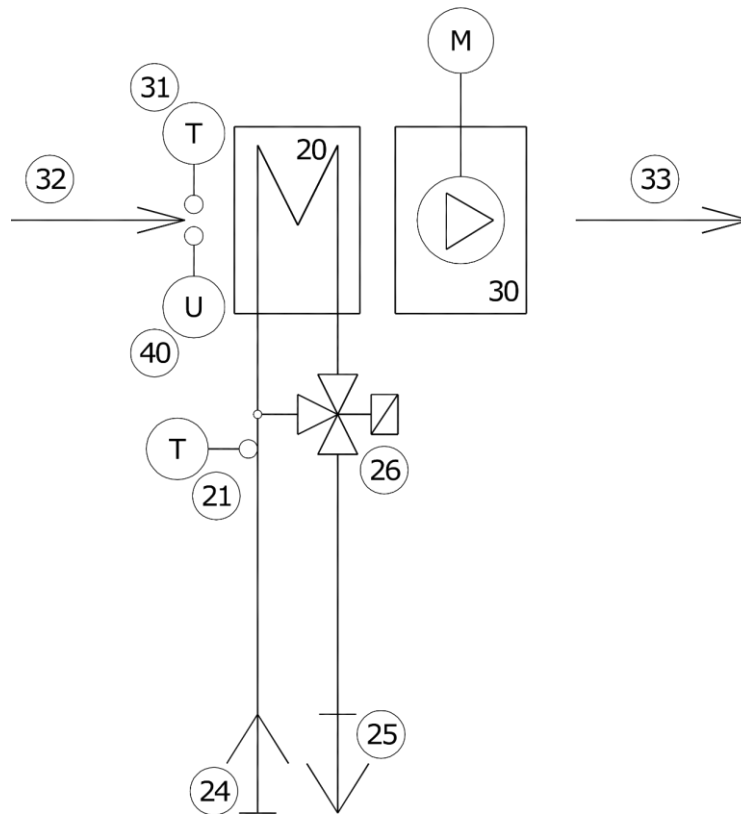

- 20 Water coil
- 21 Inlet water temperature probe
- 24 Water inlet (from radiant system)
- 25 Water outlet (to radiant system)
- 26 3-way water valve

- 30 Fan
- 31 Temperature probe
- 32 Air inlet
- 33 Air outlet
- 40 Humidity probe

Model 020_035_100_A (isothermal)

Model 050_A (isothermal)

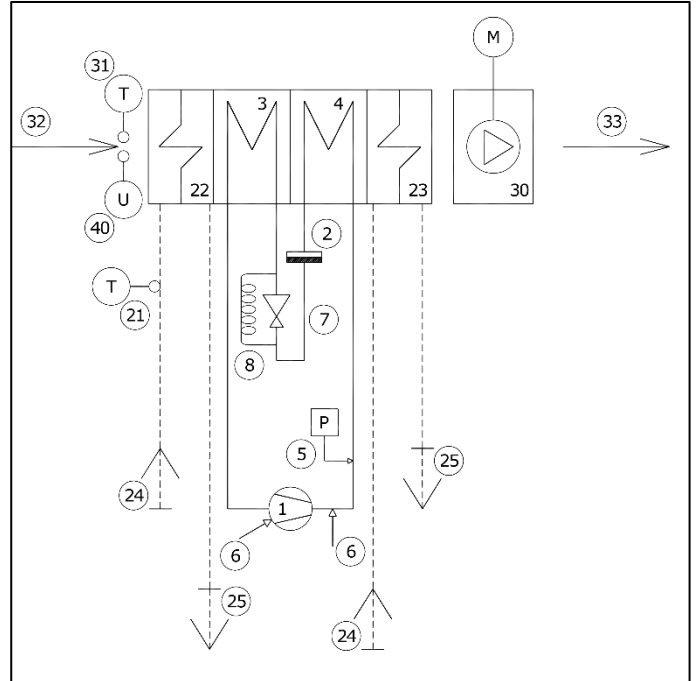
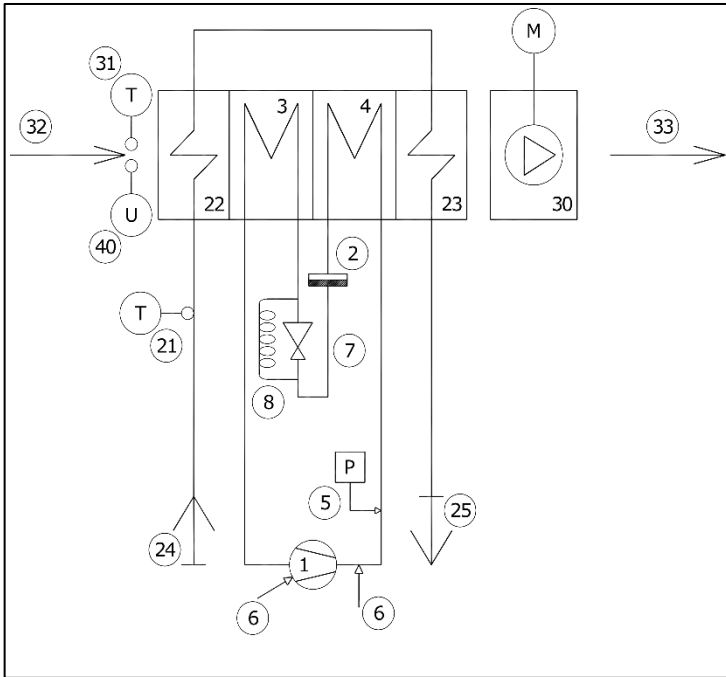

- 1 Compressor
- 2 Filter drier
- 3 Evaporator
- 4 Condenser
- 5 High pressure safety switch
- 6 Service connections
- 7 Throttling device
- 8 Capillary equalization (only models 100)

- 21 Inlet water temperature probe
- 22 Pre-cooling coil
- 23 Post-cooling coil
- 24 Water inlet (from radiant system)
- 25 Water outlet (to radiant system)

- 30 Fan
- 31 Temperature probe
- 32 Air inlet
- 33 Air outlet
- 40 Humidity probe

Model 020_035_I (hybrid)

Model 050_I (hybrid)

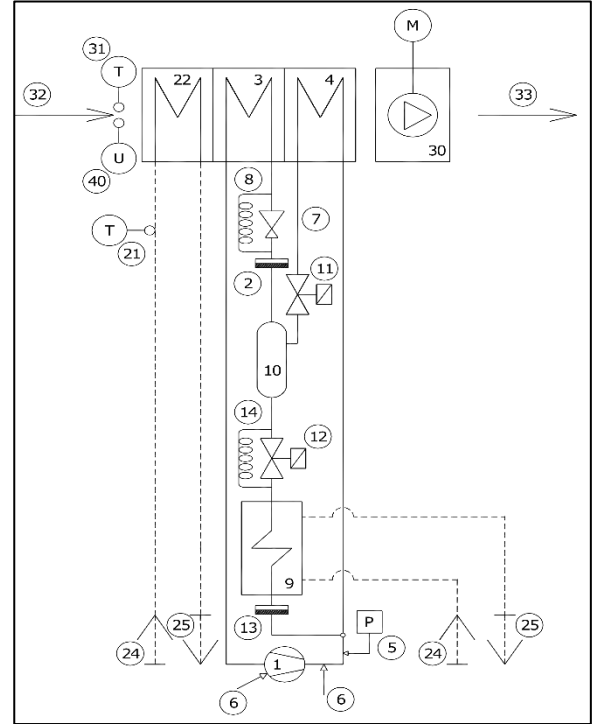
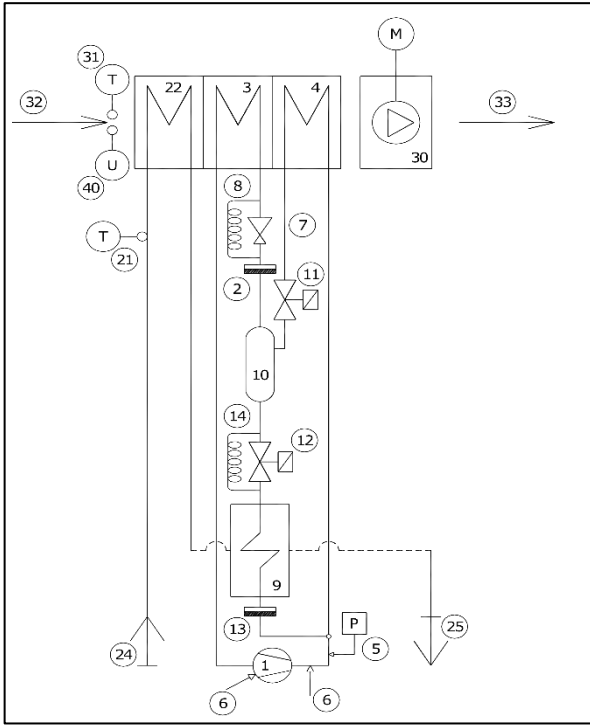

Model 100_I (hybrid)

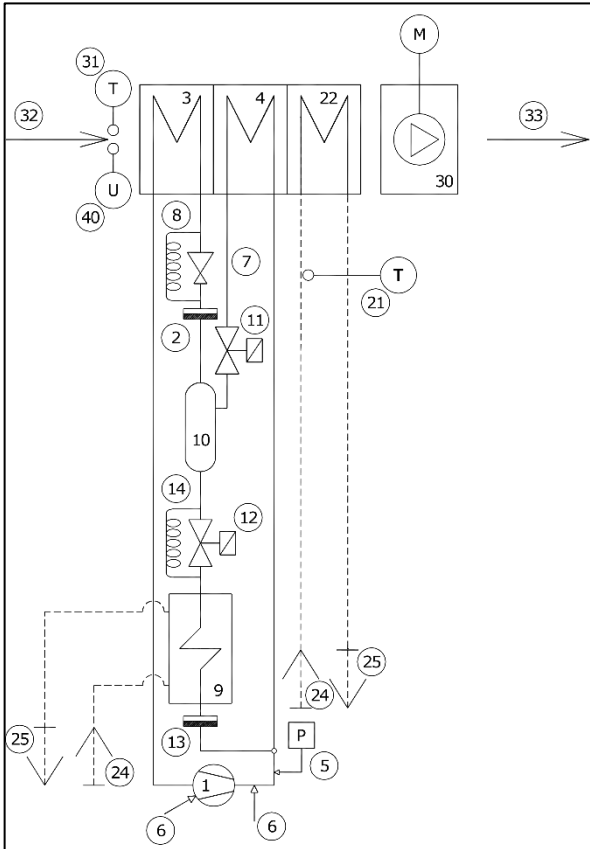

- 1 Compressor
- 2 Filter drier
- 3 Evaporator
- 4 Condenser
- 5 High pressure safety switch
- 6 Service connections
- 7 Throttling device
- 8 Capillary equalization (only models 100)
- 9 Plate condenser
- 10 Liquid receiver
- 11 Solenoid valve for ambient temperature control
- 12 Solenoid valve 2 for ambient temperature control (only models 100)
- 13 Mechanical filter (only models 100)
- 14 Capillary equalization ambient temperature control (only models 100)

- 21 Inlet water temperature probe
- 22 Pre-cooling coil
- 24 Water inlet (from radiant system)
- 25 Water outlet (to radiant system)

- 30 Fan
- 31 Temperature probe
- 32 Air inlet
- 33 Air outlet
- 40 Humidity probe

3.2 PROJECT CRITERIA

All copper pipes are realized under our specifications, in order to control completely the construction process and improve our quality. Each pipe answers to the requirements imposed by the regulations and is verified with FEM calculation in the more stressed point at 180° and at the maximum pressure allowed by safety devices, considering appropriate safety coefficients. All units have a stainless-steel condensate tray below the coils.

4 ELECTRIC CIRCUITS

4.1 ELECTRICAL DEVICES

The electrical panel is created and wired according to the regulations mentioned in the Declaration of Conformity. You should add a fuse to the domestic electrical implant, in order to protect the unit. All the remote controls are implemented with low voltage signals, powered by an isolation transformer.

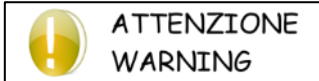

To turn off RER/REV units, use the ON/OFF key on the display. If you turn off the supply, the unit loses the clock control and this affects the correct functioning of time bands program. Moreover, if the power supply is removed, the servomotors for dampers may be in an incorrect position.

5 DISPLAY

The advanced control is composed by an electronic power board and a display, which allows to control the unit and to modify all the functions.

Here below are listed the functions of the different keys and of all the present screens

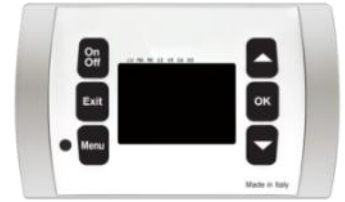

5.1 BUTTONS



ON-OFF KEY

- On the main screen, it allows to turn off the unit
- On the 'OFF' screen, it allows to turn on the unit



EXIT KEY

- It allows to exit and come back to the main screen
- If you are modifying a value, it allows to exit from the modification
- From the main screen, holding down EXIT for 4 seconds, it allows to display the software version



MENU KEY

- On the main screen, it allows to enter in the first screen of the 'user menu'
- On time bands programming screens, it allows to modify the day you are programming



UP KEY

- It allows to slide from screen to screen or to modify a value



OK KEY

- It allows to execute what is displayed or to confirm a value



DOWN KEY

- It allows to slide from screen to screen or to modify a value

5.2 MAIN MASK



- USE OF KEYS**
- With OFF you turn off the unit
 - By keeping pushed EXIT, you display temporarily the software version
 - With MENU you enter the user menu
 - If the unit is in manual mode, use UP and DOWN to increase/decrease the exchange level
 - With OK you can change the ionization level (only if present)

1
 IONIX indicates the ionizer level, press OK to modify. See dedicated manual. (only if JR present)

Operating mode
 No symbol: manual functioning
 time bands functioning
 automatic functioning

Season set

- No symbol: mid season
- Summer
- Winter



- on the top, indicates the current day
- **00:00** on the top right it indicates the current time
- **25°C** current temperature
- **54%** current humidity
- fresh air flow set (from 0 to 5)
- unit managed via Modbus

Air treating

- dehumidification
- cooling
- dehumidification and cooling
- heating
- No symbol: no air treatment

Cleaning filters alert
 CLEAN THE AIR FILTERS remember to check the state of cleanliness of the air filters.
 To hide the writing simply press the EXIT key

Pipe cleaning and replacement signaling
 CLEAN or REPLACE HOSES reminds you to check the cleaning/replacement of the ionizer tubes (if present)
 To hide the writing simply press the EXIT key

5.3 USER MENU

The user menu is composed by 9 easy-to-use screens, for the basic configurations of the unit:

1. Unit control: manual, time bands or automatic *
2. Season: summer, mid-season or winter
3. Set of the desired summer/winter temperature *
4. Set of the desired humidity *
5. Alarms management *
6. Time-bands programming *
7. Day and time setting
8. Unit status displaying
9. Password request

* Screen not always present

Each screen has a number on the right part, in order to simplify its use.

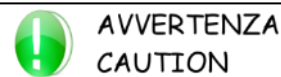

- USE OF KEYS**
- With UP and DOWN you slide from one screen to another (some screens do not always appear)
 - Press EXIT to exit and to return to the main screen
 - With OK you execute the function indicated on the screen

Here are the possible screens of the 'user menu':

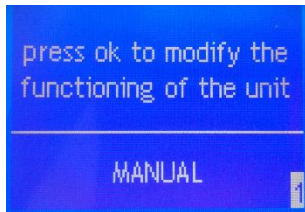

Screen 1 of the user menu allows to set the functioning of the unit:

1. MANUAL: humidity and temperature required, the on/off and the renewal can be changed via the appropriate screens
2. TIME BANDS: the on/off of the machine, the humidity and the desired temperature and the renewal will work as set in the time bands programming menu
3. AUTOMATIC: the humidity and temperature are pre-set to optimal values and cannot be changed, the on/off and the renewal can be modified via the appropriate screens
(the screen does not appear if: the unit is controlled by Modbus serial)

- press OK to enter the modification phase, press UP and DOWN to modify and press OK to confirm and to exit from the modification phase
- press EXIT to exit and to return to the main screen
- press DOWN to move to the next screen

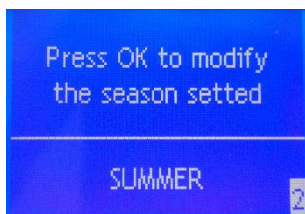

Screen 2 of the user menu allows to set the active season:

1. SUMMER: renewal, dehumidification and cooling treatment (except for RER/REV_A units)
2. WINTER: renewal and heating treatment
3. MID SEASON: only renewal
(the screen does not appear if: the unit is controlled by Modbus serial)

- press OK to enter the modification phase, press UP and DOWN to modify and press OK to confirm and to exit from the modification phase
- press EXIT to exit and to return to the main screen
- press UP to come back to the previous screen
- press DOWN to move to the next screen

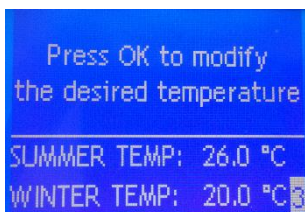

Screen 3 of the user menu allows to set the desired temperature

(the screen does not appear if: the unit is controlled by a Modbus serial or if it is not set in manual mode)

- press OK to enter in the modification phase
- press UP and DOWN to modify the first value
- press OK to confirm and go to the following value
- press UP and DOWN to modify the second value
- press OK to confirm and exit from the modification phase
- press EXIT to exit and to return to the main screen
- press UP to come back to the previous screen
- press DOWN to move to the next screen

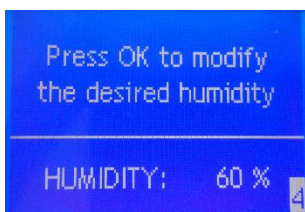

Screen 4 of the user menu allows to set the decided humidity

(the screen does not appear if: the unit is controlled by a Modbus serial or if it is not set in manual mode)

- press OK to enter the modification phase, press UP and DOWN to modify and press OK to confirm and to exit from the modification phase
- press EXIT to exit and to return to the main screen
- press UP to come back to the previous screen
- press DOWN to move to the next screen

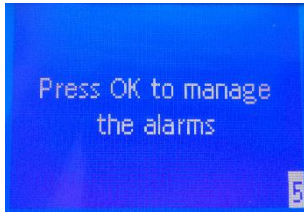

Screen 5 of the user menu allows management of the active alarms
(the screen appears if there are active alarms)

- press OK to enter the alarm menu
- press EXIT to exit and to return to the main screen
- press UP to come back to the previous screen
- press DOWN to move to the next screen

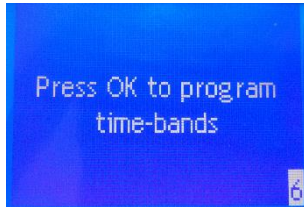

Screen 6 of the user menu allows to program time bands
(the screen does not appear if the unit is controlled via Modbus serial or if it is not set in time bands)

- press OK to enter the time-bands menu
- press EXIT to exit and to return to the main screen
- press UP to come back to the previous screen
- press DOWN to move to the next screen

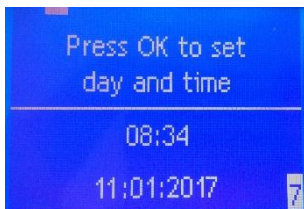

Screen 7 of the user menu allows to set data and time, necessary for the correct functioning of time-bands and other functions of the unit

You will modify consecutively:

1. the day of the week
 2. the hour
 3. the minutes
 4. the day
 5. the month
 6. the year
- press OK to enter in the modification phase
press UP and DOWN to modify the setting
press OK to confirm and to go to the following modification
having arrived at the last modification, with OK you confirm and exit from the modification phase
 - press EXIT to exit and to return to the main screen
 - press UP to go back to the previous screen
 - press DOWN to go to the next screen

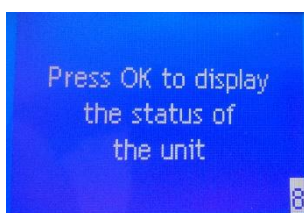

Screen 8 of the user menu allows to view the unit status so what is ON or OFF and the reading of the temperature and humidity probes

- press OK to enter the unit status menu
- press EXIT to exit and to return to the main screen
- press UP to come back to the previous screen
- press DOWN to move to the next screen

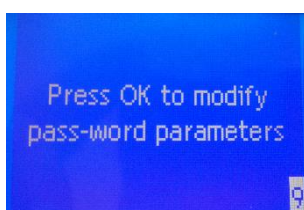

Screen 9 of the user menu allows to modify the parameters protected by password and allows the access to the installer menu

- press OK to enter the screen with password request
- press EXIT to exit and to return to the main screen
- press UP to come back to the previous screen

5.4 ALARMS MENU

This menu is available only if there is an alarm and it allows to display the active alarm and, if possible, to reset it.

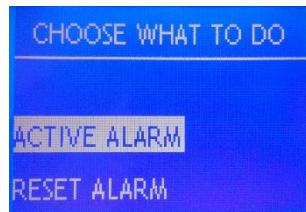

On the left you find the screen which allows choosing whether to display the alarm or to reset it

- press EXIT to exit and to return to the main screen
- press UP and DOWN to select what to do
- press OK to confirm the choice and to access the dedicated screen indicated below



On the left you find an example of alarm display: in the low part you see the device in alarm or the type of alarm; in this example, the alarm is on the compressor, for high pressure this screen is compulsory for the assistance in case of alarms

Press EXIT to exit and come back to the previous screen

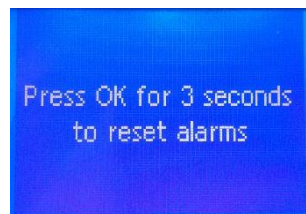

On the left you find the screen to reset the alarms. Only some alarms can be reset and you can proceed by paying attention to the fact that the cause of the alarms has not been solved and the alarm could appear again.

- pressing OK for 3 seconds, the alarm is reset and you come back to the main screen
- press EXIT to exit and come back to the alarms menu

5.5 UNIT STATUS MENU

This menu is always accessible and allows to display all the information regarding the unit status, specifically the following lines: supply fan, extraction fan, compressor, gas valve, recirculation damper, external dampers, pump contact, modulating water valve, ambient temperature, ambient humidity, water temperature, water coil anti-freeze temperature, recovery system defrost temperature, flow temperature, external temperature, ambient CO₂, dehumidification request, cooling request, heating request, free cooling request, free cooling damper, filter cleaning, ionizing tubes, cleaning tubes, replacing tubes.

Some devices can be optional and their presence depends on the type of the unit; in this case some dashes will appear on the corresponding line.

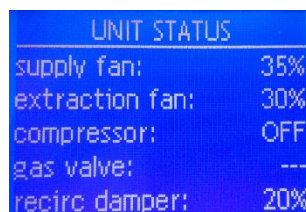

On the left you find the screen dedicated to the unit status. In this case we see that the supply fan is working at 35%, the extraction fan is working at 30%, the compressor is OFF, the gas valve is not present and the recirculation damper is open at 20%.

- press UP and DOWN to scroll and display other lines
- press EXIT to exit and to return to the main screen

5.6 TIME BANDS MENU

This menu is accessible only if the unit is set in time bands mode and allows to program the bands, that manage on/off of the unit, summer temperature, winter temperature, humidity and air renewal.

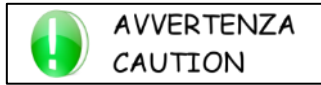

It is very important to set the current time and date, go to page 7 of the user menu (more information in the previous paragraphs)

Default values are:

- Unit always turned on (24 h/day and 7 days/week)
- Desired summer temperature always set at 26,0°C (24 h/day and 7 days/week)
- Desired winter temperature set for all days:
 - o 20°C from 08:00 to 20:00
 - o 18°C from 20:00 to 08:00
- Desired humidity always set at 55% (24 h/day and 7 days/week)
- Fresh air flow desired always set at level 3 of 5 (24 h/day and 7 days/week)

You can set different parameters for each hour of the day and for each day of the week.

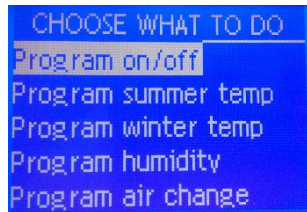

On the left you find the screen which allows you to choose what to do:

- press EXIT to exit and to return to the main screen
- press UP and DOWN to select what to do
- press OK to confirm the choice and to access the dedicated screen indicated below

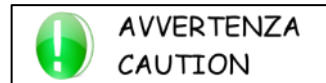

the “program ionizer” choice appears only and exclusively if an ionizer is present.

5.6.1 Programs

Selecting a program accesses to the programming screen; below is the humidity program:

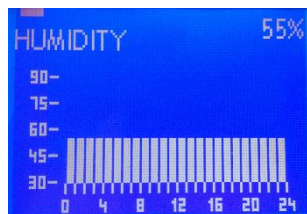

- once entered, the first bar will flash from 00.00 to 01.00; also the set value (upper right part) will flash
- in the upper left part, you find the rectangle indicating the day you are programming
- below the day-rectangle, you find the topic you are programming: “HUMIDITY”
- in the lower part, there is the bar indicating the 24 hours
- on the left you find the bar indicating the desired humidity you can set

USE OF KEYS



- pressing OK you change the time to program
- pressing MENU, you change the day to program
- pressing UP and DOWN you modify the programming of the flashing hour
- With EXIT you return to the previous screen
- keeping pressed OK and MENU, you copy the program of the active day to the following day

5.6.2 Guide

Selecting this guide, it appears 5 screens which explain how to set the time bands program.

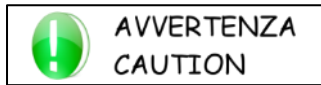

USE OF KEYS

- With UP and DOWN you slide from a screen to another (5 total screens)
- With EXIT you return to the previous screen

5.6.3 Default recovery

It is possible to completely cancel the programming of the time bands and to start again from the default values. Selecting Restore Defaults provides access to a page that allows restoration of all the values of the time bands.

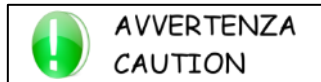

USE OF KEYS

- Pressing for 3 seconds OK, you recover all the values
- With EXIT you return to the previous screen

5.7 OTHER SCREENS

5.7.1 Software version

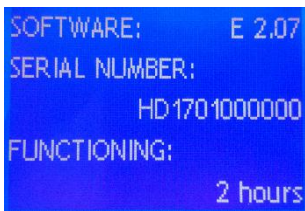

This page shows software version, serial number and operating hours; to visualize this screen hold down for 3 seconds the EXIT key; the screen is displayed for few seconds and then it returns automatically to the main screen.

5.7.2 Password

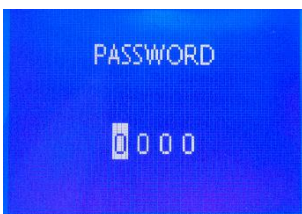

This page is used to enter the password to modify the advanced parameters

- press EXIT to exit and to return to the main screen
- press UP and DOWN to set each number of the password
- press OK to turn to the modification of the following value or to confirm

Password to enter the installer menu = 0010

6 TECHNICAL DATA

6.1 TECHNICAL DATA SHEET

		RER 015			RER 020			RER 035		
		W	A	I	W	A	I	W	A	I
Compressor	type	-	Reciprocating		-	Reciprocating		-	Reciprocating	
Refrigerant circuits	No.	0	1		0	1		0	1	
Refrigerant	type	-	R513A		-	R513A		-	R513A	
Refrigerant load	kg	-	0,15	0,39	-	0,18	0,65	-	0,37	1,5
Dehumidification capacity	l/24h	18	15	15	29	24,5	24,5	43	36	36
Efficiency of heat recovery in winter (1)	%	93			92			91		
Efficiency of heat recovery in summer (2)	%	90			88			87		
Total cooling capacity	W	1190	0	800	1920	0	1300	2700	0	2380
Cooling capacity provided by the chiller	W	1190	721	1030	1920	1058	1512	2700	2194	3134
Thermal capacity recovered in winter	W	620			1096			1448		
Thermal capacity recovered in summer	W	210			370			498		
Compressor power	W	-	230		-	212		-	754	
Absorbed power	W	35	230		40	250		50	800	
Maximum absorbed power	W	110	410		170	510		250	1000	
Absorbed current	A	0,4	1,7		0,4	1,9		0,5	5	
Maximum absorbed current	A	1	2,8		1,5	4		2,2	7,2	
Inrush current	A	1	18		1,5	19		2,2	18	
Power supply	V / ph / Hz	230 / 1~+N / 50			230 / 1~+N / 50			230 / 1~+N / 50		
Nominal water coil flow	l/h	250	125		400	200		570	360	
Water pressure drops	kPa	12	14	16	50	25	24	50	22	22
Supply air fans	No.	1			1			1		
Exhaust air fans	No.	1			1			1		
Nominal air flow	m ³ /h	160			260			380		
Renewal air flow	m ³ /h	0 – 80			0 – 130			0 – 190		
Available static pressure	Pa	210			170			190		
Sound pressure level (3)	dB(A)	36	37		38	39		40	42	
Stock temperature limit	°C	-10 / +43			-10 / +43			-10 / +43		
Stock humidity limit	%	90			90			90		
Dimensions (base x depth x height)	mm	960 x 610 x 250			1125 x 730 x 250			1125 x 730 x 300		
Unladen weight	kg	40	50		50	60		60	70	



ATTENZIONE WARNING

Units in version "I", to function, need to be always supplied with water: otherwise they cannot work and they will block. Operation without water causes damage to the machine and will invalidate the warranty

Units in version "A" can function also without water. In this case the air coming out from the unit will be warmer than the air entering the unit while the dehumidification capacity will be significantly reduced.

Units in version "W" without water do not block, but they cannot dehumidify, neither heating or cooling.

Dehumidification, cooling capacity and absorbed power are declared at the nominal point of +26°C, 65% RH, with water inlet at +15°C (+10°C only for RER/REV in version W).

1. Winter efficiency is declared with ambient air conditions: +20°C, 50% RH and outdoor air conditions -5°C, 80% RH.
2. Summer efficiency is declared with ambient air conditions: +26°C, 65% RH and outdoor air conditions: +35°C, 50% RH.
3. Sound pressure level measured in free field, 2 m from the unit, with a correction factor Q=2, according to the regulation ISO 9614, ducted unit with static pressure 50 Pa.

In different conditions the values will vary: the further from the nominal point, the larger will be the variations.

		RER 050			RER 100		
		W	A	I	W	A	I
Compressor	<i>type</i>	-	Reciprocating		-	Rotary	
Refrigerant circuits	<i>No.</i>	0	1		0	1	
Refrigerant	<i>type</i>	-	R513A		-	R410A	
Refrigerant load	<i>kg</i>	-	0,45	1,65	-	0,95	1,85
Dehumidification capacity	<i>l/24h</i>	58	48	48	120	100	100
Efficiency of heat recovery in winter (1)	%	93			91		
Efficiency of heat recovery in summer (2)	%	89			86		
Total cooling capacity	<i>W</i>	3650	0	3230	7700	0	6800
Cooling capacity provided by the chiller	<i>W</i>	3650	2800	4000	7700	5713	8161
Thermal capacity recovered in winter	<i>W</i>	1974			3852		
Thermal capacity recovered in summer	<i>W</i>	670			1290		
Compressor power	<i>W</i>	-	770		-	1361	
Absorbed power	<i>W</i>	60	800		160	1500	
Maximum absorbed power	<i>W</i>	250	1100		510	2000	
Absorbed current	<i>A</i>	0,54	5,5		1,5	7,8	
Maximum absorbed current	<i>A</i>	2,2	7,7		4,2	11	
Inrush current	<i>A</i>	2,2	28		4,2	41	
Power supply	<i>V / ph / Hz</i>	230 / 1~+N / 50			230 / 1~+N / 50		
Nominal water coil flow	<i>l/h</i>	790	500		1800	1000	
Water pressure drops	<i>kPa</i>	40	30	29	50	32	25
Supply air fans	<i>No.</i>	1			2		
Exhaust air fans	<i>No.</i>	1			1		
Nominal air flow	<i>m³/h</i>	520			1000		
Renewal air flow	<i>m³/h</i>	0 - 260			0 - 500		
Available static pressure	<i>Pa</i>	170			160		
Sound pressure level (3)	<i>dB(A)</i>	43	44		44	47	
Stock temperature limit	<i>°C</i>	-10 / +43			-10 / +43		
Stock humidity limit	%	90			90		
Dimensions (base x depth x height)	<i>mm</i>	1545 x 810 x 375			1490 x 965 x 450		
Unladen weight	<i>kg</i>	70	80		130	140	



**ATTENZIONE
WARNING**

Units in version "I", to function, need to be always supplied with water: otherwise they cannot work and they will block. Operation without water causes damage to the machine and will invalidate the warranty.

Units in version "A" can function also without water. In this case the air coming out from the unit will be warmer than the air entering the unit while the dehumidification capacity will be significantly reduced.

Units in version "W" without water do not block, but they cannot dehumidify, neither heating or cooling.

Dehumidification, cooling capacity and absorbed power are declared at the nominal point of +26°C, 65% RH, with water inlet at +15°C (+10°C only for RER/REV in version W).

1. Winter efficiency is declared with ambient air conditions: +20°C, 50% RH and outdoor air conditions -5°C, 80% RH.
2. Summer efficiency is declared with ambient air conditions: +26°C, 65% RH and outdoor air conditions: +35°C, 50% RH.
3. Sound pressure level measured in free field, 2 m from the unit, with a correction factor Q=2, according to the regulation ISO 9614, ducted unit with static pressure 50 Pa.

In different conditions the values will vary: the further from the nominal point, the larger will be the variations.

		REV 020			REV 035			REV 050		
		W	A	I	W	A	I	W	A	I
Compressor	type	-	Reciprocating		-	Reciprocating		-	Reciprocating	
Refrigerant circuits	No.	0	1		0	1		0	1	
Refrigerant	type	-	R513A		-	R513A		-	R513A	
Refrigerant load	kg	-	0,18	0,65	-	0,37	1,5	-	0,45	1,65
Dehumidification capacity	l/24h	29	24,5	24,5	43	36	36	58	48	48
Efficiency of heat recovery in winter (1)	%	92			91			93		
Efficiency of heat recovery in summer (2)	%	88			87			89		
Total cooling capacity	W	1920	0	1300	2700	0	2380	3650	0	3230
Cooling capacity provided by the chiller	W	1920	1058	1512	2700	2194	3134	3650	2800	4000
Thermal capacity recovered in winter	W	1096			1448			1974		
Thermal capacity recovered in summer	W	370			498			670		
Compressor power	W	-	212		-	754		-	770	
Absorbed power	W	40	250		50	800		60	800	
Maximum absorbed power	W	170	510		250	1000		250	1100	
Absorbed current	A	0,4	1,9		0,5	5		0,54	5,5	
Maximum absorbed current	A	1,5	4		2,2	7,2		2,2	7,7	
Inrush current	A	1,5	19		2,2	18		2,2	28	
Power supply	V / ph / Hz	230 / 1~+N / 50			230 / 1~+N / 50			230 / 1~+N / 50		
Nominal water coil flow	l/h	400	200		570	360		790	500	
Water pressure drops	kPa	50	25	24	50	22	22	40	30	29
Supply air fans	No.	1			1			1		
Exhaust air fans	No.	1			1			1		
Nominal air flow	m³/h	260			380			520		
Renewal air flow	m³/h	0 – 130			0 – 190			0 – 260		
Available static pressure	Pa	170			170			170		
Sound pressure level (3)	dB(A)	38	39		39	41		43	44	
Stock temperature limit	°C	-10/ +43			-10 / +43			-10 / +43		
Stock humidity limit	%	90			90			90		
Dimensions (base x depth x height)	mm	600 x 380 x 980			650 x 430 x 1050			700 x 515 x 1430		
Unladen weight	kg	50	60		55	65		75	90	



Units in version "I", to function, need to be always supplied with water: otherwise they cannot work and they will block. Operation without water causes damage to the machine and will invalidate the warranty.

Units in version "A" can function also without water. In this case the air coming out from the unit will be warmer than the air entering the unit while the dehumidification capacity will be significantly reduced.

Units in version "W" without water do not block, but they cannot dehumidify, neither heating or cooling.

Dehumidification, cooling capacity and absorbed power are declared at the nominal point of +26°C, 65% RH, with water inlet at +15°C (+10°C only for RER/REV in version W).

1. Winter efficiency is declared with ambient air conditions: +20°C, 50% RH and outdoor air conditions -5°C, 80% RH.
2. Summer efficiency is declared with ambient air conditions: +26°C, 65% RH and outdoor air conditions: +35°C, 50% RH.
3. Sound pressure level measured in free field, 2 m from the unit, with a correction factor Q=2, according to the regulation ISO 9614, ducted unit with static pressure 50 Pa.

In different conditions the values will vary: the further from the nominal point, the larger will be the variations.

6.2 AIR FLOWS AND PRESSURE

All our RER units install electronic radial fans with inverter integrated and brushless motor.

It is set at a standard speed. Please refer to the installation paragraph to calibrate the unit.

The air flow is on the x-axis, the useful static pressure is on the y-axis and it is declared with free outlet.

SUPPLY SIZE 015

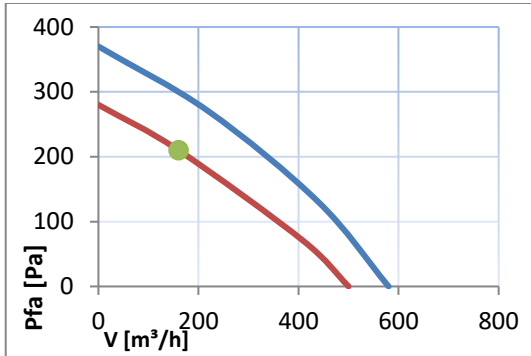

EXTRACTION SIZE 015

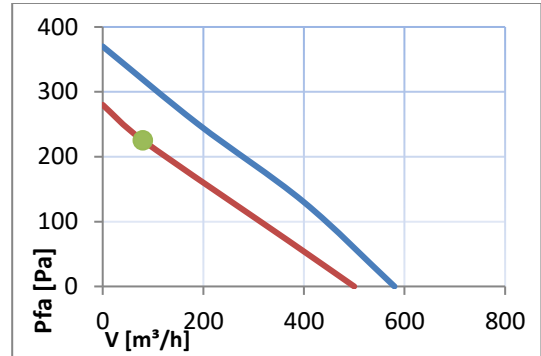

SUPPLY SIZE 020

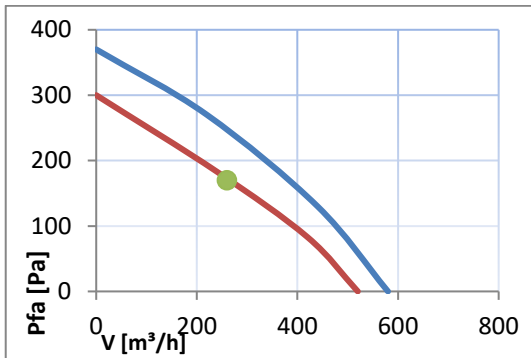

EXTRACTION SIZE 020

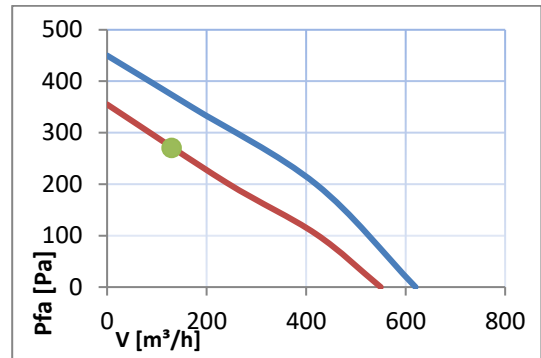

SUPPLY SIZE 035

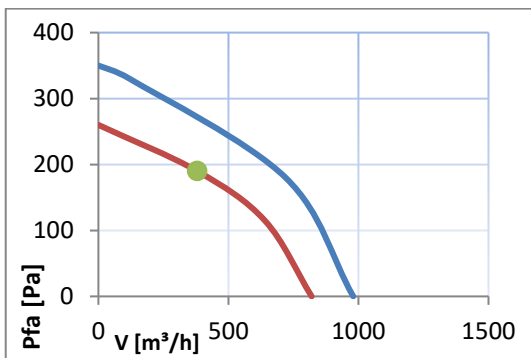

EXTRACTION SIZE 035

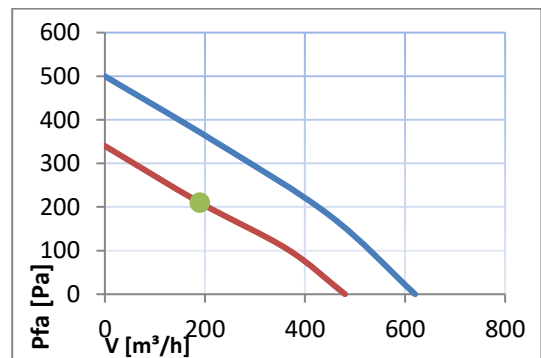

SUPPLY SIZE 050

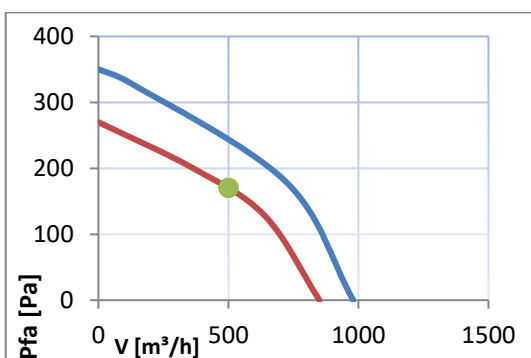

EXTRACTION SIZE 050

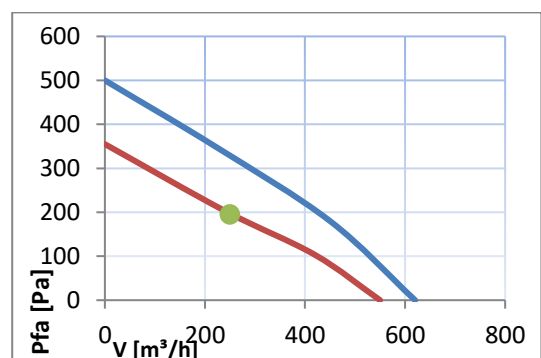

SUPPLY SIZE 100

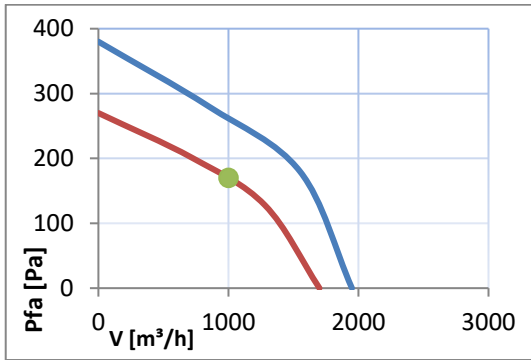

EXTRACTION SIZE 100

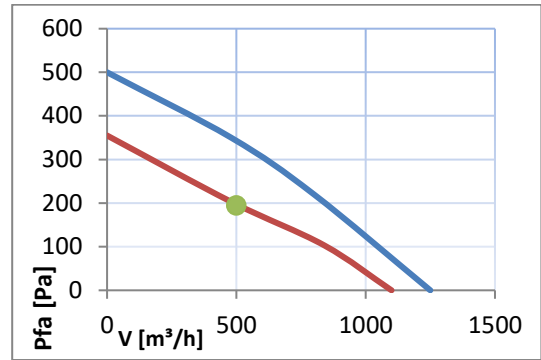

Low curve = Maximum acceptable noise limit

High curve = Maximum limit

6.3 HYDRAULIC CIRCUIT LOAD LOSSES

On the x-axis there is the water flow, on the y-axis there are the hydraulic circuit water pressure drop.

SIZE 015 W

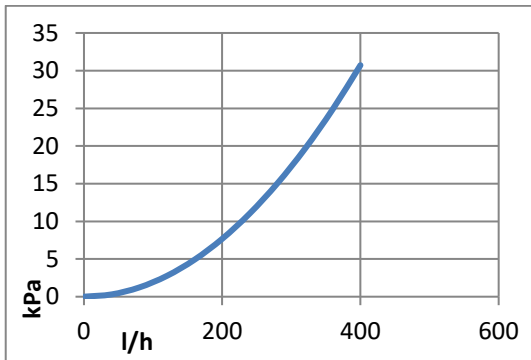

SIZE 015 A and I

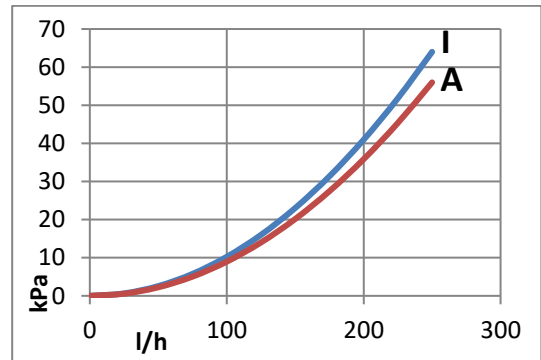

SIZE 020 W

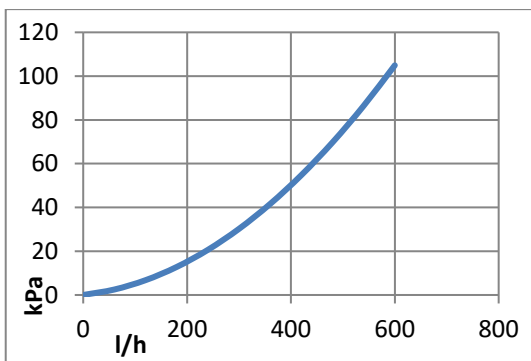

SIZE 020 A and I

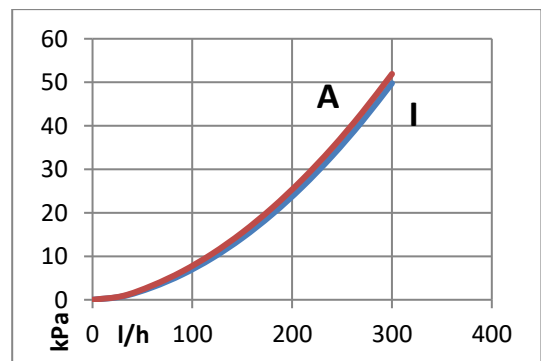

SIZE 035 W

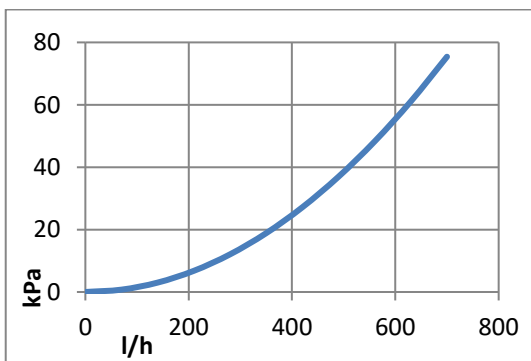

SIZE 035 A and I

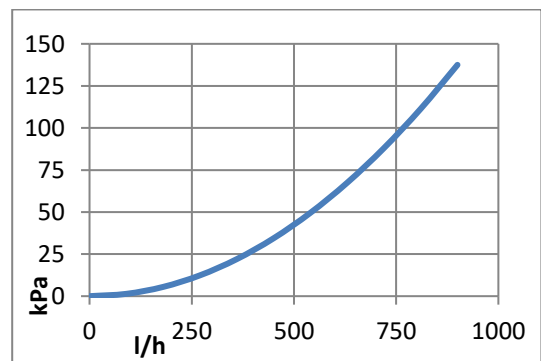

SIZE 050 W

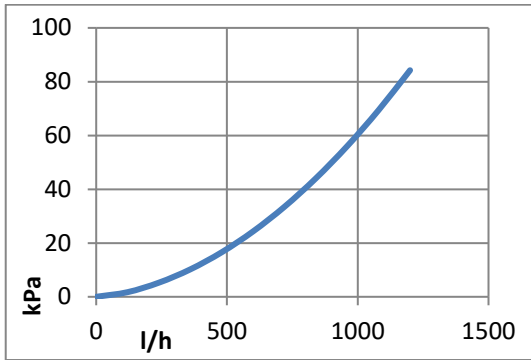

SIZE 050 A and I

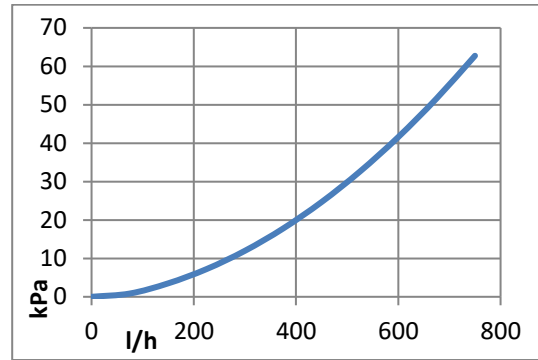

SIZE 100 W

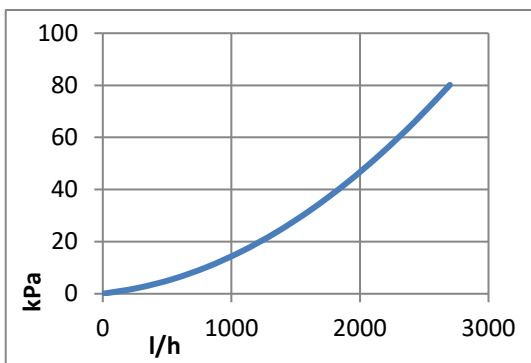

SIZE 100 A and I

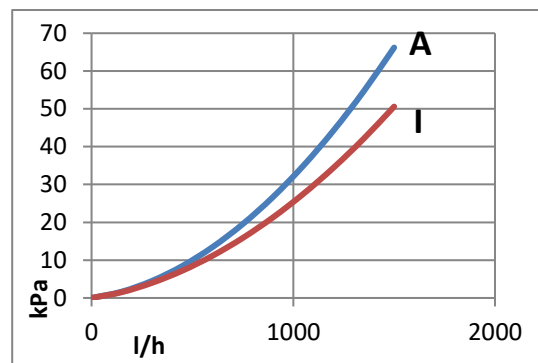

6.4 TYPE W UNIT COOLING CAPACITY

On the x-axis is the temperature of the incoming water (°C), on the y-axis is the cooling capacity (kW). The three different lines represent the different recirculation air temperatures.

Winter

SIZE 015 W

Summer

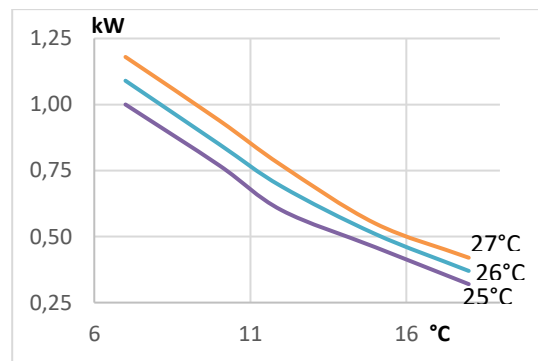
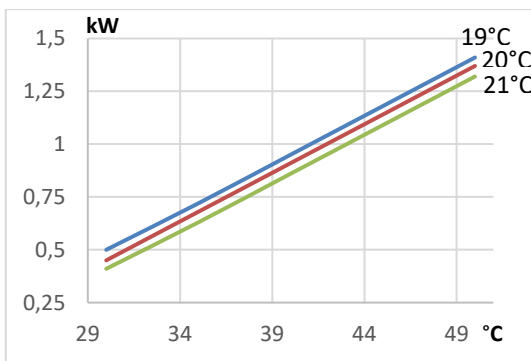

Winter

SIZE 020 W

Summer

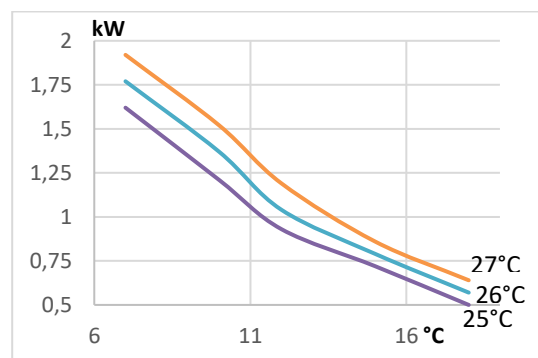
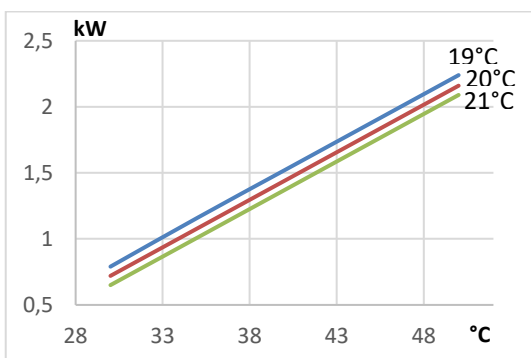

Winter

SIZE 035 W

Summer

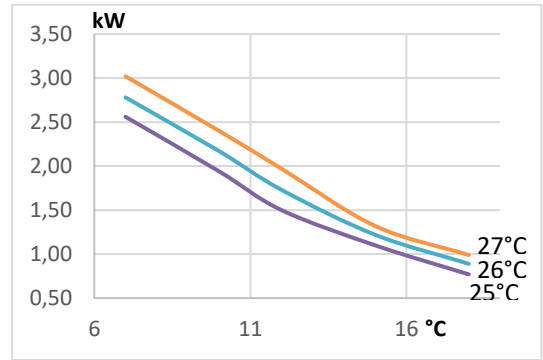
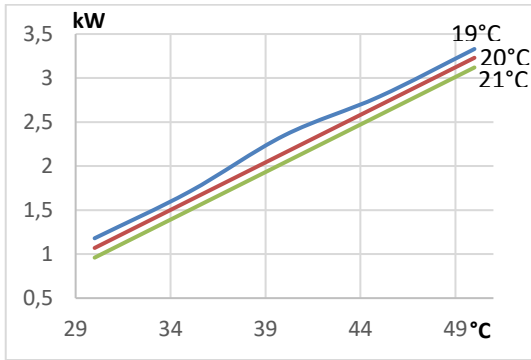

Winter

SIZE 050 W

Summer

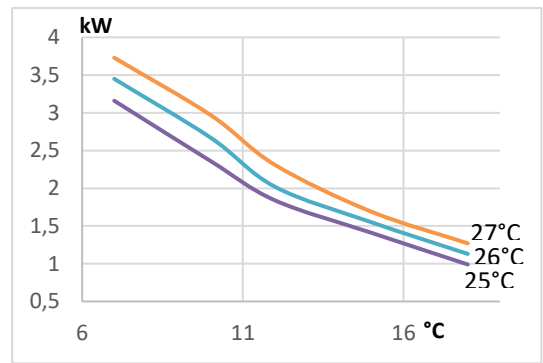
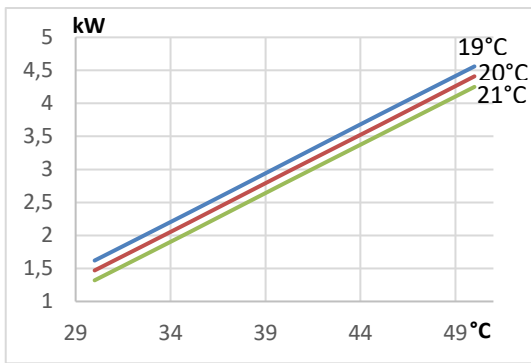

Winter

SIZE 100 W

Summer

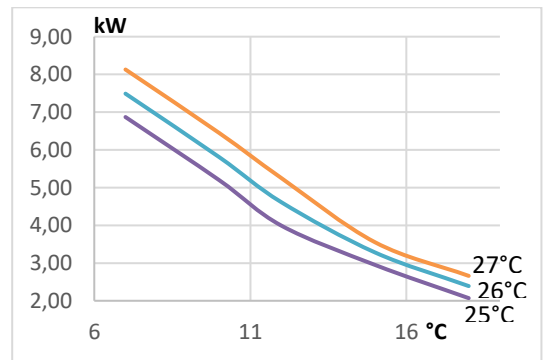
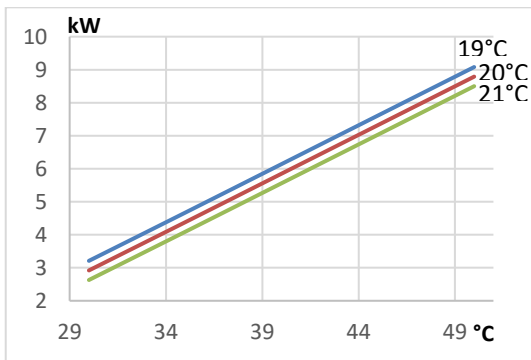

7 MAINTENANCE AND PROBLEM SOLVING

7.1 FAULTS AND ANOMALIES

List of the most common reasons that may cause the unit block or malfunction.



**ATTENZIONE
WARNING**

Pay the utmost attention in the execution of the suggested operations for resolution of the various problems: excessive lack of attention can cause serious injuries. It is recommended to contact the manufacturer or a qualified technician after having identified the failure.

NR	FAULT	ANALYSIS OF POSSIBLE CAUSES	CORRECTIVE ACTIONS
1	The unit does not start	No electrical power supply to the unit	Check its presence on the power supply terminals
		The display is in OFF	Press ON/OFF to turn it on
		Fire alarm (if configured)	Press ON/OFF to reset the alarm and restart the unit
		There are alarms present	Check the presence of alarms on the terminal, eliminate the causes and restart the unit.
2	The display cannot start	There is no power supply to the unit	Make reference to anomaly 1
		Wrong wiring in the connection between display and power board	Check the status of the connection cable, check that the connection A-A and B-B is respected, do not pass the connection cable together with power cables
3	The compressor does not start	The unit has just been turned on and the compressor starts a bit later	Wait a few minutes
		Intervention of the internal thermo-protector	Unplug the unit, wait for the compressor to cool down and check to see if it restarts by reconnecting the power supply. Identify the cause of the intervention and eliminate it
		High-pressure protection on the refrigerant circuit	Make reference to anomaly 5
4	The fan is noisy	An excessively high flow rate has been set	Check the air flow and decrease it if necessary
		The ducts are too small	Check the air duct layout and correct it
5	High pressure alarm <i>From the first signal to the third, the reset is automatic, if it occurs four times in less than twelve hours, the reset is manual</i>	High pressure anomaly for insufficient air flow	Check that the air flows are correct Check the cleanliness of heat exchange coils, filters and heat recovery unit
		Presence of high pressure anomaly due to insufficient water flow [version I only (hybrid)]	Check the pressure drop, the correct functioning of the hydraulic circuit and the correct water flow
		Water temp probe anomaly (errors can be caused by short circuit or by interruption of the probe)	Check the status of the water temperature probe. If the problem is not solved, replace the probe
6	Ambient temperature probe alarm	Probe abnormality (errors can be caused by short circuit or by interruption of the probe)	Check the status of the probe. If the problem is not solved, replace the probe
7	Ambient humidity probe alarm	Probe abnormality (errors can be caused by short circuit or by interruption of the probe)	Check the status of the probe. If the problem is not solved, replace the probe

NR	ANOMALIA	ANALISI DELLE POSSIBILI CAUSE	AZIONI CORRETTIVE
8	Water temperature probe alarm	Probe abnormality (errors can be caused by short circuit or by interruption of the probe)	Check the status of the probe If the problem is not solved, replace the probe
9	Water coil anti-freeze temperature probe alarm	Probe abnormality (errors can be caused by short circuit or by interruption of the probe)	Check the status of the probe If the problem is not solved, replace the probe
10	Heat recovery defrost temperature probe alarm	Probe abnormality (errors can be caused by short circuit or by interruption of the probe)	Check the status of the probe If the problem is not solved, replace the probe
11	Alarm of the ambient CO ₂ probe	Probe abnormality (errors can be caused by short circuit or by interruption of the probe)	Check the status of the probe If the problem is not solved, replace the probe
12	Supply temperature probe alarm	Probe abnormality (errors can be caused by short circuit or by interruption of the probe)	Check the status of the probe If the problem is not solved, replace the probe
13	Water low-temperature anomaly	Water probe reads a low temperature	Increase the temperature of the water supplied to the unit
14	Water high temperature anomaly	Water probe reads a high temperature	Decrease the temperature of the water supplied to the unit
15	Freezing-risk of the water coil anomaly	The water temperature probe reads a temperature lower than 6°C: risk of water coil freezing (and damage)	Check the status of the recovery
			Check the correct functioning of extraction fan
16	Clean filters signal on the main page	Filters has to be cleaned or replaced	Refer to the paragraph "Cleaning/replacing air filters"



**PERICOLO
DANGER**

***When there are alarms connected with the water probe, turn off the unit and call a qualified technician for the reparation. Serious risk of damaging the unit.
If you do not turn off the unit, the warranty automatically expires.***

7.2 MAINTENANCE TABLE

Units will operate correctly only if the maintenance operation suggested in the table are executed following the period indicated.

Operation	Period
Air filters	<ul style="list-style-type: none"> • Visual check and cleaning every 6 months (or more frequently in case of dirty ambiances) • Replacement at least every 12 months
Heat recovery unit	<ul style="list-style-type: none"> • Visual inspection and cleaning every 12 months • Replacement when necessary or at least every 4 years
Check correct condensate discharge downstream the unit	Every 6 months
Check air vents and grilles cleaning, indoor and outdoor	Every 6 months
Visual and acoustic check (check sound emitted by the unit and its integrity)	Every 6 months
Visual check of refrigerant and hydraulic circuit (oil, refrigerant and/or water leakage)	Every 12 months
Visual check of electrical panel, clamps and wiring	Every 12 months
Status, fixing and balance of the fans	Every 4 years
Condensate tray cleaning	Every 4 years
Thermal exchange coil cleaning	Every 4 years

ORDINARY MAINTENANCE OPERATIONS REGISTER

Write in the following table the maintenance operation executed.

Operation	Year _____		Year _____		Year _____	
	1 st semester	2 nd semester	1 st semester	2 nd semester	1 st semester	2 nd semester
Air filters						
Heat recovery unit						
Check correct condensate discharge downstream the unit						
Check air vents and grilles cleaning, indoor and outdoor						
Visual and acoustic check (check sound emitted by the unit and its integrity)						
Visual check of refrigerant and hydraulic circuit (oil, refrigerant and/or water leakage)						
Visual check of electrical panel, clamps and wiring						
Status, fixing and balance of the fans						
Condensate tray cleaning						
Thermal exchange coil cleaning						

EXTRAORDINARY MAINTENANCE OPERATIONS REGISTER

Write in the following the extraordinary maintenance operations executed.

7.3 ORDINARY MAINTENANCE

7.3.1 Exploded view to identify the panels you need to open

For the ordinary maintenance, it is sufficient to open the lower panels for RER units or front panels for REV units. Unscrew the screws and provide for maintenance operations.



By removing access panels, filters may fall down. Therefore, pay maximum attention during the opening phase to prevent the air filters from falling to the ground.

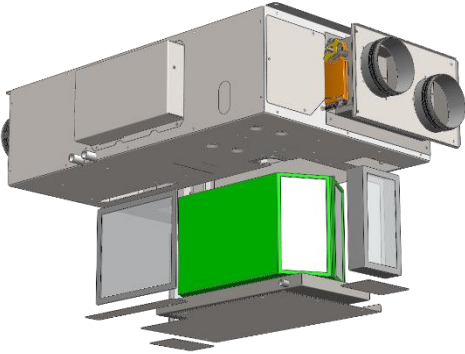

RER 015

1. Unscrew the panel and extract the exhaust air filter for maintenance
2. Unscrew the panel and extract the supply air filter for maintenance
3. Unscrew the panel, remove the condensate tray (attention it could contain water) and extract the heat recovery unit for maintenance
4. Unscrew the panel and extract the external air filter for maintenance

RER 020 e RER 035

1. Unscrew the panel for fan maintenance
2. Unscrew the panel and extract the supply air filter for maintenance
3. Unscrew the panel, remove the condensate tray (attention it could contain water) and extract the heat recovery unit for maintenance
4. Unscrew the panel and extract the external air and exhaust air filters for maintenance

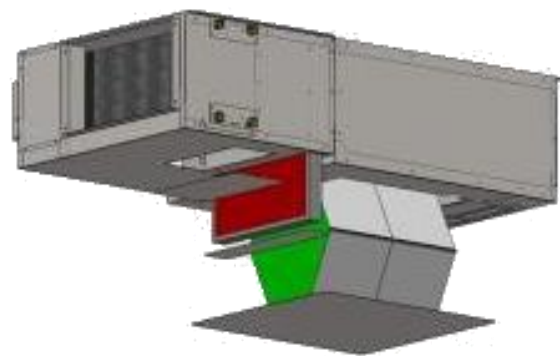
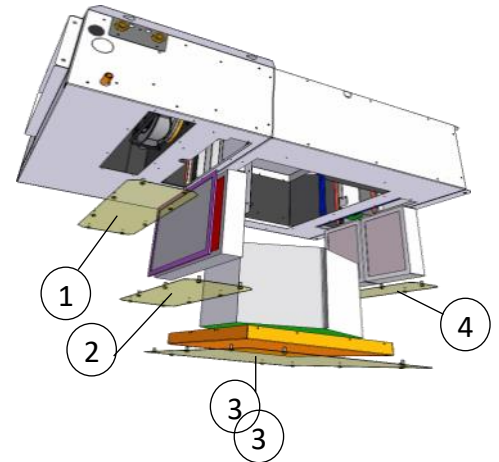

RER 050

1. Unscrew the panel for fan maintenance
2. Unscrew the panel and extract the supply air filter for maintenance
3. Unscrew the panel, remove the condensate tray (attention it could contain water) and extract the heat recovery unit for maintenance
4. Unscrew the panel and extract the exhaust air filters for maintenance

RER 100

1. Unscrew the panel for fan maintenance and to extract the supply air filter for maintenance
2. Unscrew the panel, remove the condensate tray (attention it could contain water) and extract the heat recovery unit for maintenance
3. Unscrew the panel and extract external air and exhaust air filters for maintenance

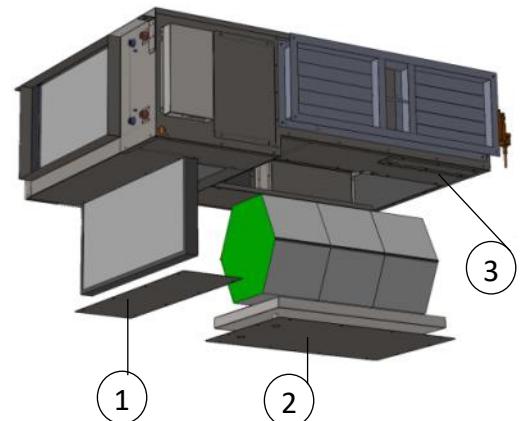

REV 020 e REV 035

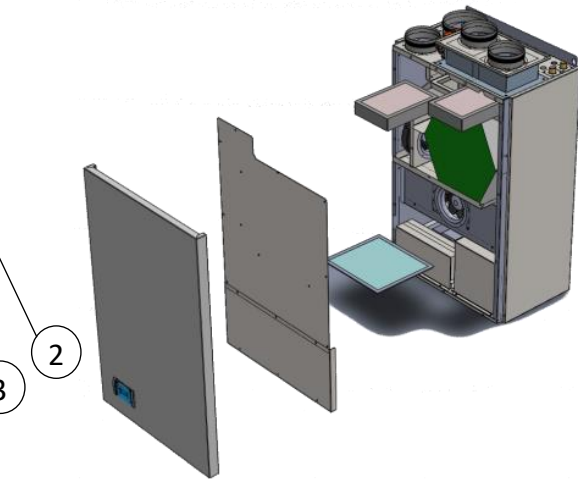

Remove the blank front panel and unscrew the various internal panels for maintenance:

1. External air filter
2. Exhaust air filter
3. Condensate tray and heat recovery unit
4. Expulsion fan
5. Supply fan
6. Air supply filter

REV 050

Open the front panels as shown in the right, then unscrew the screws and handwheels to remove the various internal panels for maintenance:

1. External and exhaust air filter
2. Extraction air filter
3. Recirculation air filter
4. Condensate tray and heat recovery unit
5. Expulsion fan
6. Supply fan

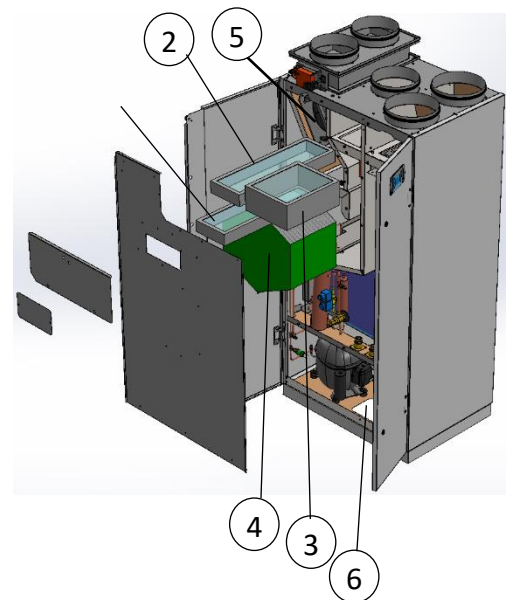

7.3.2 Cleaning the recovery unit

RER units: open the specific panel, unscrew the first handwheel and leave the tray for the drain hose hanging, unscrew the second handwheel and lower the recovery unit.

REV units: open the front panels, remove the block plate positioned above the heat recovery unit, lift the heat exchanger and remove it. Clean with a vacuum cleaner, paying attention not to do damage and mount it again. Do not use liquids to clean it.

7.3.3 Cleaning/replacing air filters

Open the panels containing the filters/dedicated panels, remove the filters and use a vacuum cleaner; if necessary, use your hands to remove impurities which may stop the correct air flux, paying attention not to damage them.

Any damaged, punctured or otherwise damaged filter must always be replaced.



Clogging of the air filters depends on use of the machine and on the installation area. Please, check periodically the cleaning status. An incorrect cleaning or the removal of the air filters from the unit, leads to serious risks about its correct functioning and integrity. If the cleaning/replacement of the filters is not respected, the warranty expires.

To remove the signal “clean the air filters” from the main screen, press the EXIT button.

7.4 EXTRAORDINARY MAINTENANCE



**ATTENZIONE
WARNING**

**The extraordinary maintenance has to be done only by qualified staff.
DO NOT IMPROVISE, WOUND OR DEATH DANGER**

7.4.1 Cleaning heat exchange coil

Remove any accumulations of dust or deposits by washing the pack with compressed air in the opposite direction according to air flux; or, as an alternative, wash it with water and non-corrosive products.

7.4.2 Electric circuit check



**PERICOLO
DANGER**

The check should be performed when there is no voltage.

Check that all the clamps are correctly fixed; if not, tighten the screws or the connectors.

Check that all the contactors or power relays, if present, are functioning and not blocked or oxidized; if not, it is compulsory to replace them/their substitution is compulsory

8 DISMANTLING OF THE UNIT

When the unit has to be dismantled, please follow the below indications:

- The refrigerant has to be recovered by qualified staff and sent to dedicated collection centres;
- The compressor oil has to be recovered and sent to the dedicated collection centres;
- If the structure and the various components cannot be used, they should be demolished and divided into material types. This is particularly important for copper and aluminium of which there are significant quantities in the machine.

This will facilitate the work carried out in the waste collection, disposal and recycling facilities and minimise the environmental impact of such processes.



**ATTENZIONE
WARNING**

Should the unit, or a part of it, be decommissioned, the parts liable to cause any hazard must be rendered harmless.

Whenever a part is replaced and the used part must be disposed of separately, always refer to the relative laws in force.

Please note it is mandatory to register the loading and unloading of special and toxic-harmful waste.

Special and toxic-harmful waste must be collected by authorised companies.

Special and toxic-harmful waste must be disposed of in compliance with the applicable laws in the user's country.

Dismantle the unit according to the requirements imposed by law in force in the user's country.

Before demolishing the unit, ask the relative Authority to perform an inspection and issue a report.

Lastly, scrap the unit in compliance with the applicable laws in the user's country.



**AVVERTENZA
CAUTION**

Dismantling and demolition must be entrusted to qualified personnel.

8.1 AMBIENT PROTECTION

The law [reg. EC 2037/00] that regulates the use of stratospheric ozone-depleting substances and greenhouse gases, bans the disposal of refrigerant gases in the environment and requires holders to collect them and return them to the dealer at the end of their useful life or take them to a suitable waste collection facility.

The refrigerant R513A and R410A are not harmful to the ozone layer, but they are included among the substances responsible for the greenhouse effect and thus fall within the scope of the aforesaid regulations.

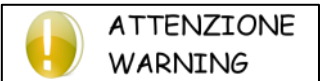

**ATTENZIONE
WARNING**

Particular attention is therefore recommended during maintenance operations in order to reduce refrigerant leaks as far as possible.

8.2 MANAGEMENT OF WASTE ELECTRICAL AND ELECTRONIC EQUIPMENT (WEEE)

This product is covered by Directive 2012/19/EU on the management of waste electrical and electronic equipment (WEEE).

The appliance must not be disposed of with household waste because it is made of different materials that can be recycled at appropriate facilities. Contact your local authority to find out where the nearest ecological platform is, so that the product can be disposed of and recycled.

Also remember that, if you purchase an equivalent appliance, the dealer is required to collect the old product for free.

The product is not potentially harmful to human health and to the environment, as it does not contain harmful substances as per Directive 2011/65/EU (RoHS), but if it is abandoned in the environment, it has a negative impact on the ecosystem.

Read the instructions carefully before using the appliance for the first time. It is recommended not to use the product for any purpose other than that for which it was intended, as there is a risk of electric shock if it is used improperly.



The crossed-out bin symbol on the sticker attached to the appliance indicates that this product complies with the legislation on waste electrical and electronic equipment.

Abandoning the equipment in the environment or disposing of it illegally are punishable by law.

9 INSTALLATION

9.1 PREAMBLE

9.1.1 Inspection

On receiving the unit, check for any damage: the machine left the factory in perfect conditions; immediately report any signs of damage to the carrier and note them on the “Delivery Slip” before signing it.

The manufacturer or its agent must be promptly notified of the extent of the damage.

The Customer should write a paper listing all the eventual relevant damages.

9.1.2 Lifting and transport

While the unit is being unloaded and positioned, utmost care must be taken to avoid abrupt or rough manoeuvres. Be very careful when transporting it inside. Do not use the unit components for lifting purposes.

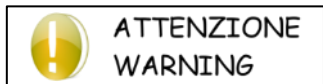

During all lifting operations, check if the unit has been properly anchored, in order to avoid falls or overturns. Do not move or lift the unit by the removable panels.

It is forbidden to tilt the unit by 30° and/or flip the unit.

9.1.3 Unpacking

The unit should be unpacked by paying attention, in order to avoid any possible damage to the unit itself; the packaging can be of different material, such as wood, paper, carton, nylon, etc. please preserve separately the different materials for the dismantling/recycling, in order to reduce the environmental impact.

9.1.4 Unit identification

Each unit has an identification label which you can find on its frame, where there is all the necessary information for the installation, maintenance and traceability of the unit.

Take note of the model, serial number, the definitive refrigerant load and the reference drawings of the unit found in the table on the side, so that it can easily be retrieved if the data plate gets worn.

Modello - Model	
Matricola - Serial number	
Data di produzione - Date of production	
Categoria PED/ CE 2014/68/UE Category	
Procedura di valutazione conformità - Conformity module	
TSe ambiente esterno (max/min) – Tse external ambient (max/min) [°C]	
TSi ambiente interno (max/min) – Tsi internal ambient (max/min) [°C]	
Max temp. di stoccaggio - Max storage temperature [°C]	
Max temp. funzionamento - Max ambient working temperature [°C]	
Min.temp.ambiente di funzionamento-Min ambient working temp. [°C]	
Refrigerante - Refrigerant [Ashrae 15/1992]	
Carica refrigerante - Refrigerant charge [kg]	
Tonnellate equivalenti CO2 – Equivalent tons CO2	
Peso a vuoto - Empty weight [kg]	
Alimentazione - Power supply	
Potenza assorbita Nominale - Nominal power input [kW]	
Corrente nominale - Nominal absorbed current [A]	
Corrente massima - Full load ampere FLA [A]	
Corrente di spunto - Starting Current LRA [A]	
Schema elettrico - Wiring diagram	

9.2 POSITIONING



**AVVERTENZA
CAUTION**

It is fundamental to ensure complete access to the unit for ordinary/extraordinary maintenance and calibration operations.

Pay attention to the following aspects when choosing the best place to install the unit and the relative connections:

- Dimensions and origin of hydraulic pipes (if present);
- Place of the power supply;
- Accessibility for use, maintenance and repair operations;
- Solidity of the anchoring plane;

Avoid fixing the machine to high heights to avoid high temperature blocks.



**ATTENZIONE
WARNING**

The installation of rubber anti-vibration damper feet is recommended for each anchorage point in order to avoid noise and vibration transmission.



**PERICOLO
DANGER**

*It is forbidden to tilt the unit more than 30° and/or flip the unit, even temporarily.
Danger of compressor rupture.*

Failure to comply with these requirements shall result in decadence of the warranty.



**ATTENZIONE
WARNING**

The conditions of the place of installation shall comply with the limits set out in paragraph “operational and functional limits”.

9.2.1 RER units (horizontal)



**ATTENZIONE
WARNING**

All RER models are designed and built for indoor installation.

Do not install the unit outdoor and make sure it is not exposed to atmospheric agents such as rain, hail, moisture, and frost.

Per installazioni a controsoffitto predisporre sempre un pannello removibile come immagine a seguire

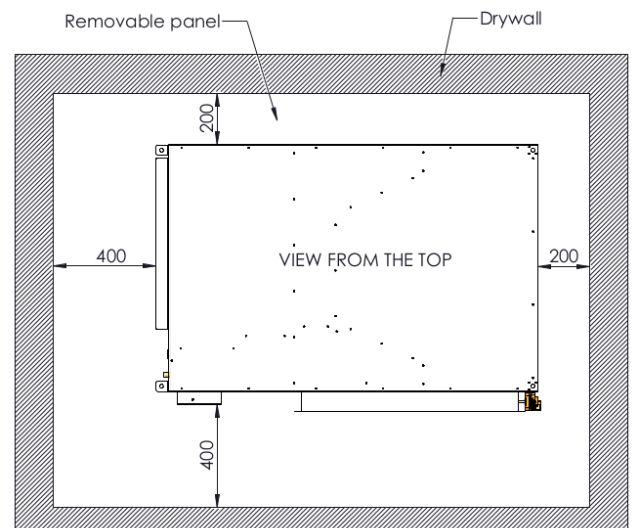
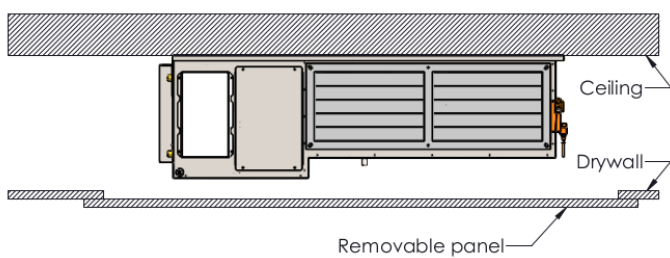

The removable panel should have the necessary dimensions to grant the access on all the sides of the unit and should be larger on the electrical panel side and on the supply air side, for the installation of optional accessories.

For the correct dimensions of the panel, please consider also the accessories fixed on the unit (i.e. plenums) and also the necessary calibration (refer to the next paragraphs).

The unit in the picture is RER 100, the indicated dimensions are the minimum suggested.

9.2.2 Models REV 020 – REV 035 (vertical)



All REV models are designed for indoor installation, or outdoors with dedicated insulation and protection panels.
Do not install the unit outside and make sure that it is not subjected to weather agents, such as rain, hailstorm, humidity and frost.

AT SIGHT INSTALLATION

For on-wall on sight installations, respect the distances indicated in the following pictures:

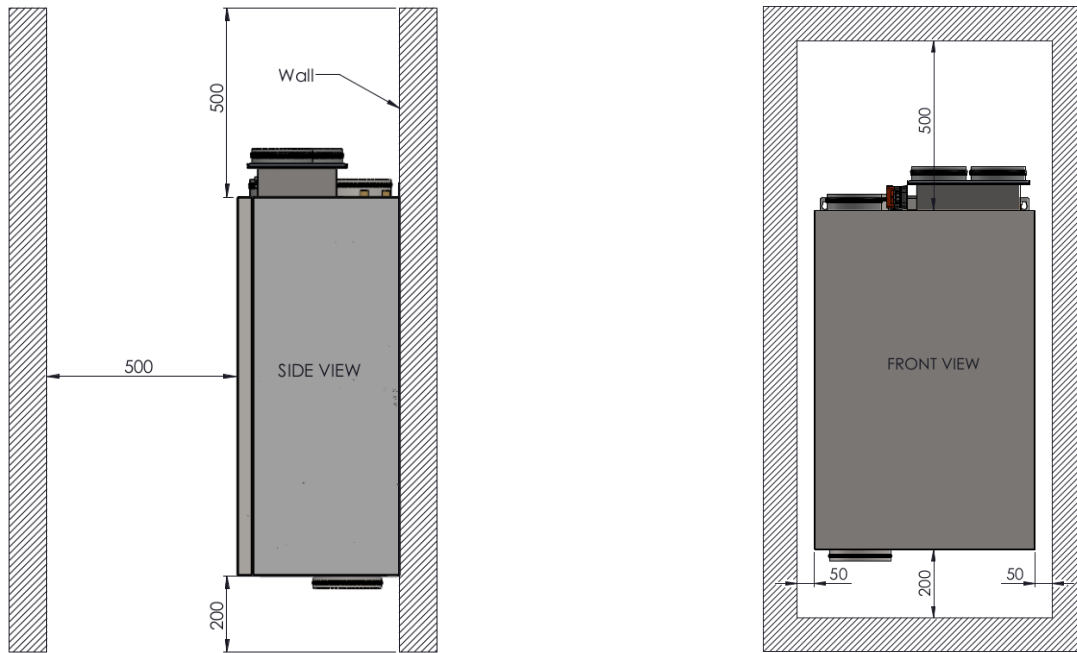

UPPER SIDE CONNECTIONS

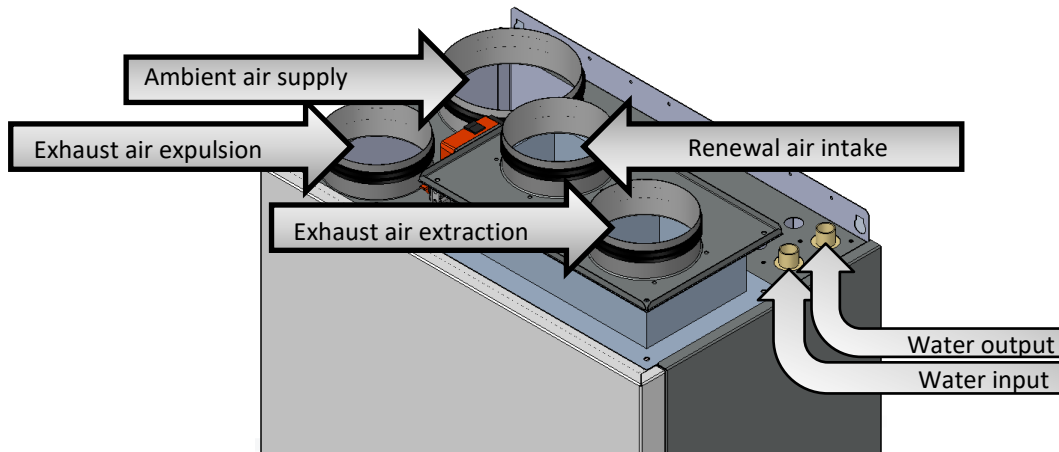

BUILT-IN INSTALLATION

For a built-in installation, both indoor or outdoor, it is necessary to consider the predisposition for a built-in-wall formwork during the building phase.

To fix the unit:

- bend with a screwdriver the two support fins located within the formwork, as shown on the picture
- insert the unit within the formwork and hang it to the two support fins

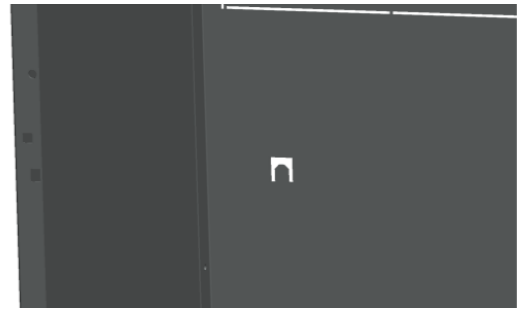

INTERNAL

EXTERNAL

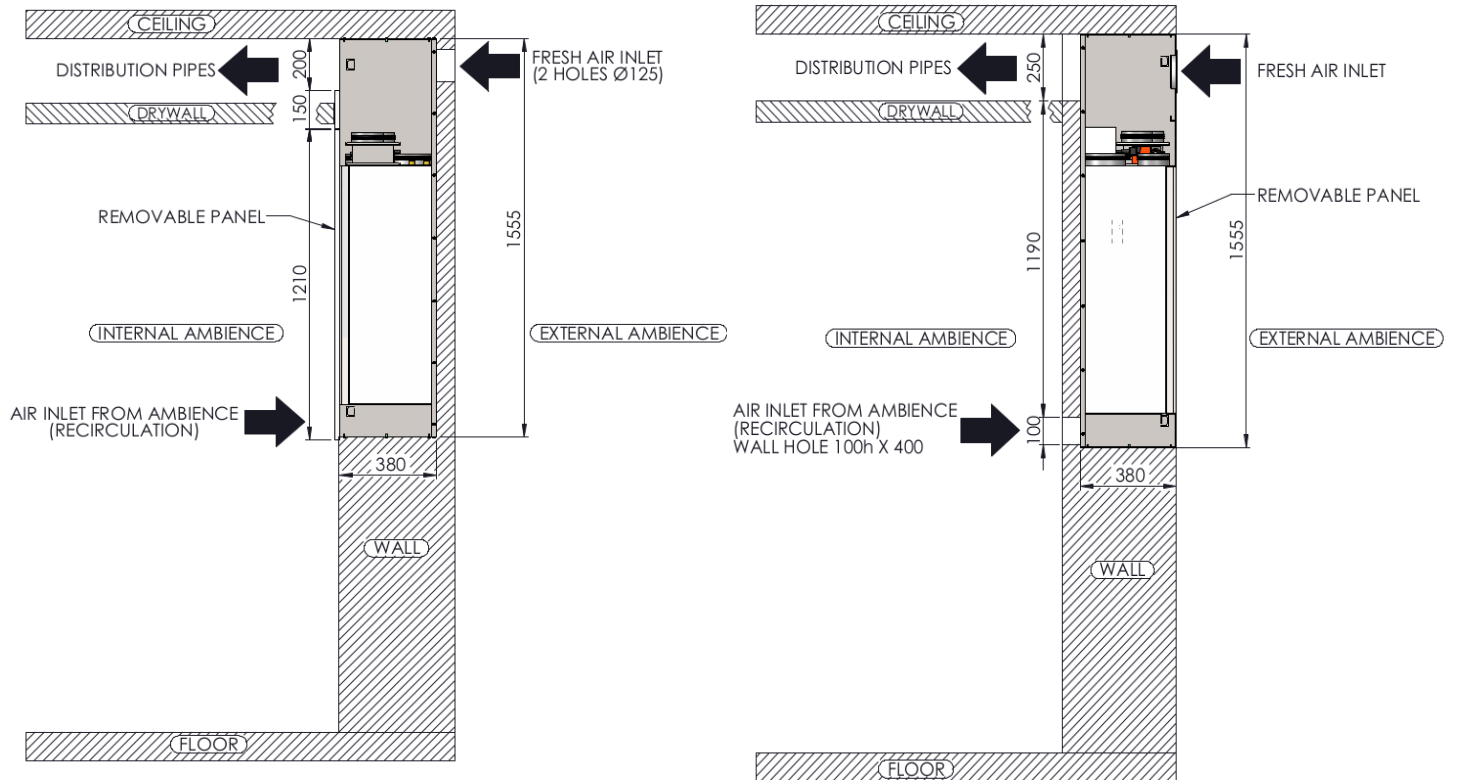

9.2.3 Model REV 050 (vertical)

AT SIGHT INSTALLATION

Per installazioni a parete a vista rispettare sempre gli spazi di rispetto indicati nelle immagini a seguire.

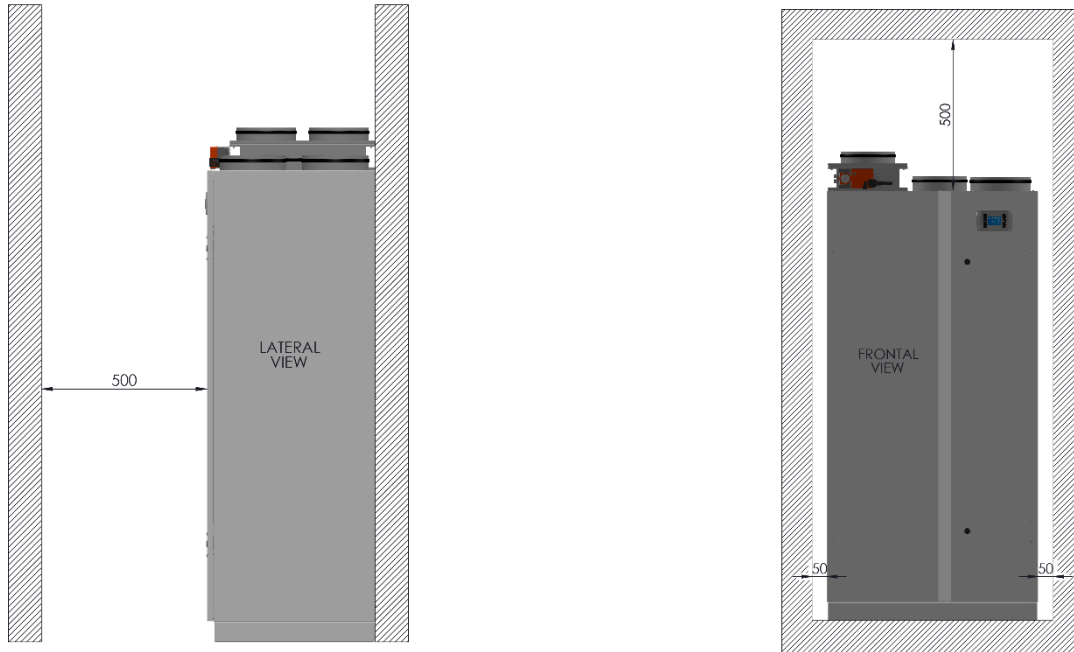

UPPER SIDE CONNECTIONS

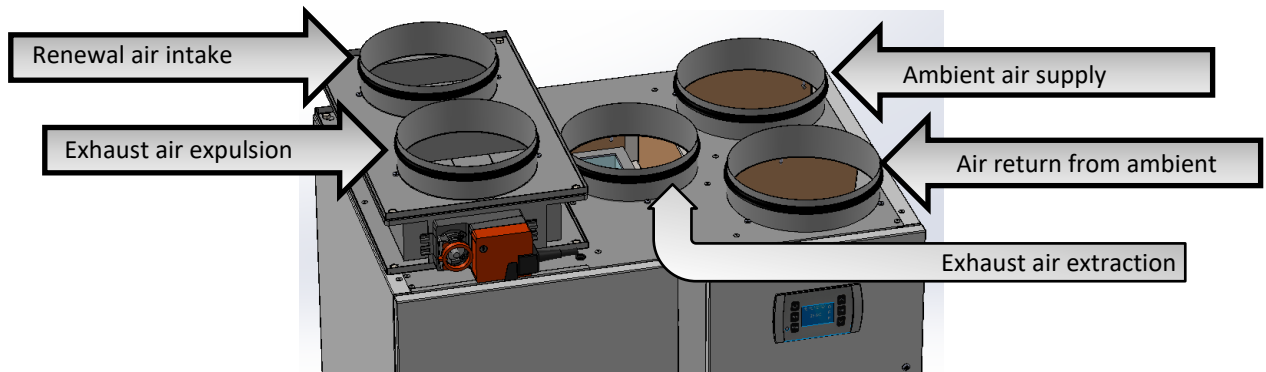

9.3 DUCTING

All the units are provided with flanges or gaskets for ducts.

The air suction for recirculation, in some installation is not connected with ducts: in this case there are very low load losses and air fluxes are, normally, unbalanced. To avoid this problem, there is a grille within the unit.



**AVVERTENZA
CAUTION**

The grille is fundamental when the suction for recirculation is not ducted; when the suction for recirculation is ducted, we suggest removing the grille, so the unit noise is limited.

RER 015

Place on the pipes' side, on the left there is the gasket for the recirculation; bend the grille until you remove it completely; do not touch if there is a panel behind the grille: it is a damper which moves independently/ an automatic damper.

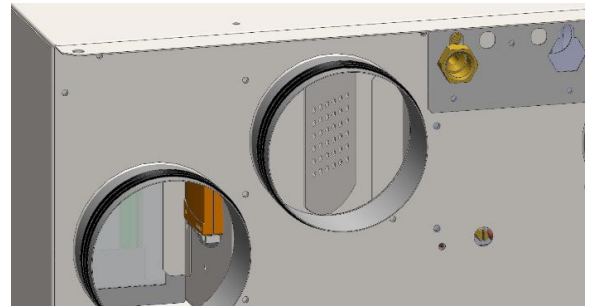
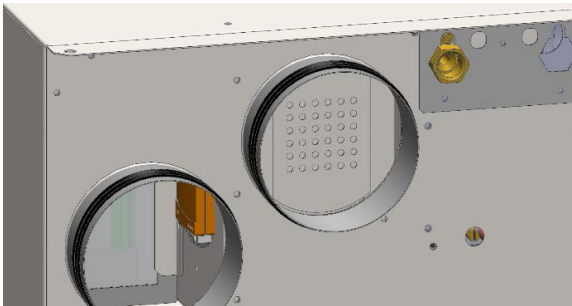

RER 020 and RER 035

Place on the pipes side, on the right there is the recirculation gasket; bend the grille towards the outside and towards the external, as shown on the pictures above; do not touch if there is a panel behind the grille: it is an automatic damper.

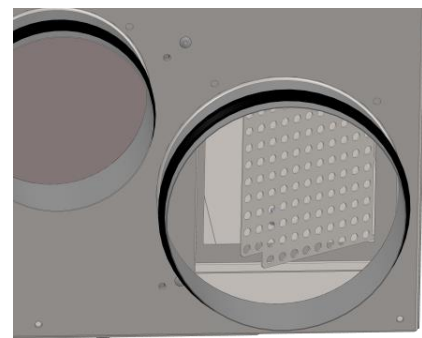
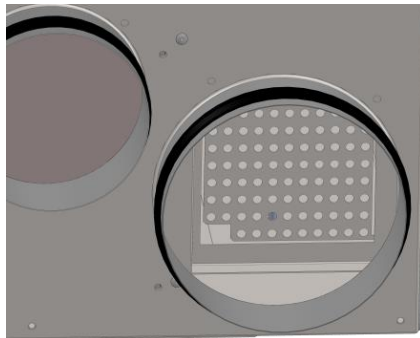

RER 050

Place on the pipes side, on the right there is the recirculation hole; bend the grille towards the external and towards the right as shown on the pictures above; do not touch if there is a panel behind the grille: it is an automatic damper.

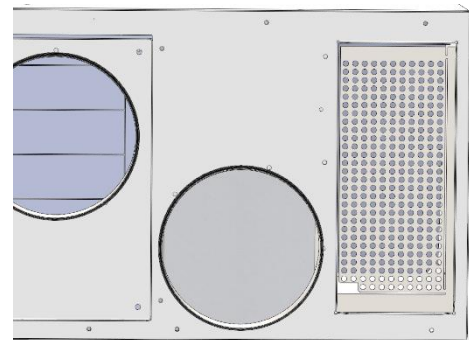
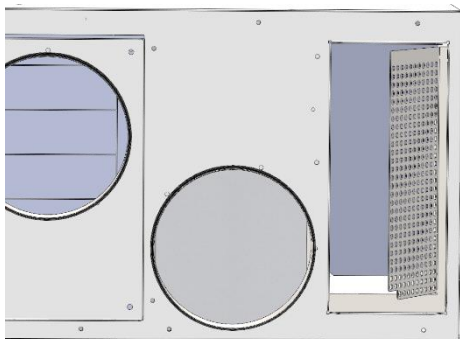

RER 100

Place on the opposite side of the electrical panel, remove the recirculation damper, break the connection points with a cutter and mount again the damper.

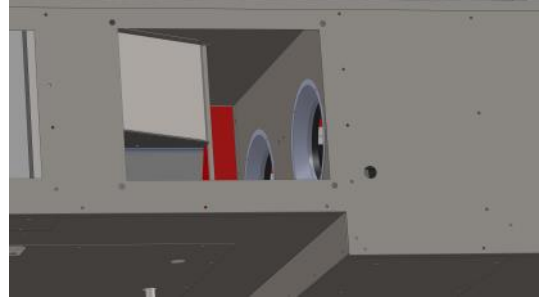
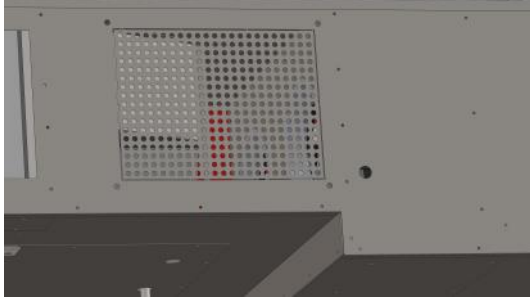

REV 020 and REV 035

Place under the unit, if there is the gasket unscrew it for the moment, with a cutter remove the connection points of the grille and mount again the gasket.

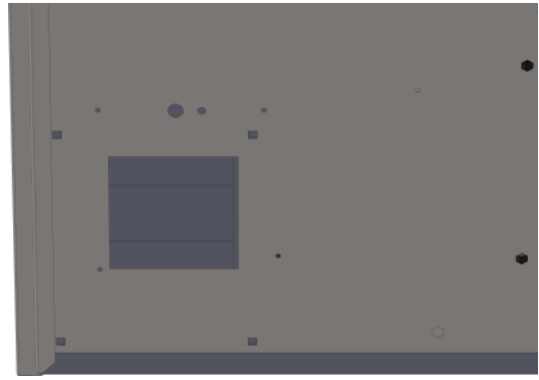
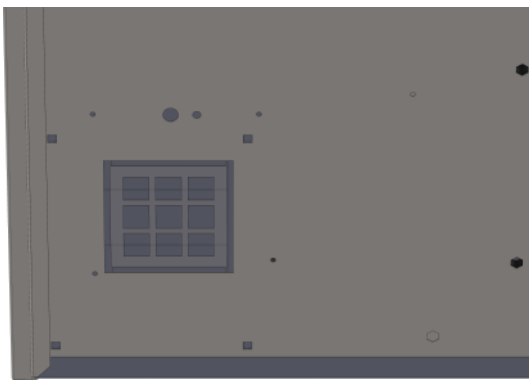

REV 050

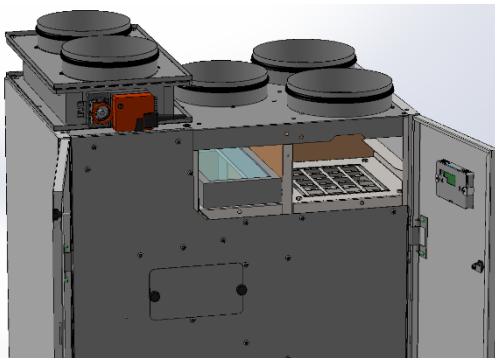

Open the front doors of the unit, unscrew the top right panel; you can remove the grid installed in the recirculation stream.

9.4 HYDRAULIC CONNECTIONS

9.4.1 Water circuit connection

It is mandatory to follow the requirements below, when implementing the hydraulic circuit, to comply with the following requirements and in any case, comply with national or local regulations.



**ATTENZIONE
WARNING**

Do not twine on the connections of the unit. With a key, block the connection and with another one, fix the adaptor.

Use flexible joints to join the pipes in order to dampen vibrations and to compensate for thermal expansion.

In case the machine has 4 water connections, it is necessary to connect the two inputs in parallel with a T and the two outputs in parallel with a T.

The following components should be installed on the piping:

- Zone valve or dedicated pump commanded from the pump contact in the clamping box to allow the water flow on the unit; if the pump absorbs a current greater than 1 A, introduce a power relay
- Temperature and pressure indicators for routine maintenance and inspections of the unit. Pressure control allows to assess the correct functioning of the expansion tank and to detect water leakage in advance
- Interception valves to close the hydraulic circuit in case of maintenance interventions
- Mechanical filter (inlet pipe) with 1 mm mesh, to protect the exchanger from the impurities present in the pipes. This requirement is, above all, necessary for commissioning
- Air vent valves, to be placed on the highest areas of the hydraulic circuit, in order to allow the air purge
- Discharge cock and drain tank, where needed, in order to empty the system for maintenance

Dimensions and position of the hydraulic connections are indicated in the dimensional drawings.

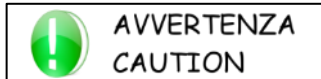

**AVVERTENZA
CAUTION**

It is fundamental that the water inlet is realized in correspondence with the connection indicated with the label "Water inlet". Otherwise the countercurrent circuitry would not be respected with the risk of malfunction, blockage or breakage of the unit.



**ATTENZIONE
WARNING**

The hydraulic circuit must be designed in such a way as to guarantee the constancy of the nominal water flow (+/- 15%) in all operating conditions.



Water characteristics for thermal plants

The standard UNI 8065/89 is the reference standard for the treatment of water in thermal plants for civil use and establishes the chemical-physical parameters useful to prevent events of fouling and corrosion inside the plants.

The indications given within the standard are schematically listed below.

FILLING AND REFILLING WATER CHARACTERISTICS	
Aspect	limpid
Total hardness	< 15°F

WATER CIRCUIT CHARACTERISTICS	
Aspect	Possibilmente limpido
pH	compreso tra 7 e 8
Hardness	<15°F
Iron (Fe)	<0,5 mg/kg
Copper (Cu)	<0,1 mg/kg

9.4.2 Condensate discharge connection

Connect with a rubber hose with an internal diameter of 16 mm. The drain pipe should not have ascents during all the way. It is necessary to activate the siphon by pouring water before turning on the unit. The following picture shows the recommended construction of the siphon.



There are 2 condensate discharges, one for the dehumidifier and one for the heat recovery unit. It is compulsory to create a siphon for each discharge; after it is possible to include a "T" connector/connection/junction for the conjunction/unity/union. It is forbidden to insert T-connectors upstream of siphons.

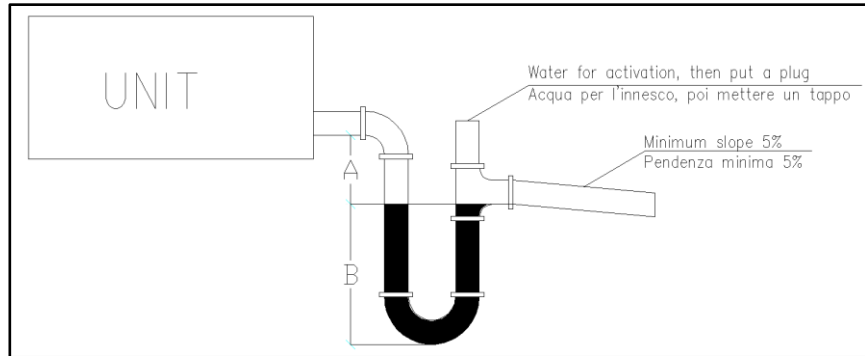

Minimum height of the siphon

A higher than 50 mm
B higher than 50 mm

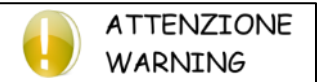

The inclination of the discharge pipe must be such that the water flows from the unit to the outside in all cases. If this does not happen and the collection tray inside the unit fills up, overflows may occur with consequent water leakage.

9.4.3 Adjustable control for supply air temperature function [optional]

For the adjustable control for supply air temperature function in heating mode, a controlled valve with a signal of 0-10 Volt should be mounted to intercept the water coming into the unit. We recommend a 3 ways valve with 4 attachments, which should have a diameter equal to the one of the unit's attachments. In the case you use a 3 ways valve with just 3 attachments, it will be necessary to connect the valve bypass and the exit of the water from the unit with a "T".

9.5 ELECTRICAL CONNECTIONS

Open the electrical panel, introduce the supply cable and the other necessary cables on the dedicated holes, realize the connections on the clamps and close the panel.



The ground lead is compulsory. The installer should provide the grounding wire with the dedicated clamp located within the electrical panel, as shown in the next picture.

The electrical connection, the power cables and the protections must be implemented according to the electrical wiring diagram attached and in compliance with local and international regulations.

	015		020		035		050		100	
	W	A - I	W	A - I	W	A - I	W	A - I	W	A - I
Suggested supply line	3G1,5	3G1,5	3G1,5	3G1,5	3G1,5	3G2,5	3G1,5	3G2,5	3G2,5	3G4
Suggested MGT switch upstream of the line	C6	C10	C10	C10	C6	C16	C6	C16	C10	C20
Plug-in terminals recommended for power cables: mod CEMBRE	BF-F608P	BF-F608P	BF-F608P	BF-F608P	BF-F608P	BF-F608P	BF-F608P	BF-F608P	BF-F608P	GF-F608P



Wiring must be carried out when the power supply is disconnected. DANGER OF DEATH!

9.5.1 Clamping box and wiring

POWER SUPPLY CONNECTION

The unit power supply must be brought to the connector shown in the figure, for each of the 3 connections to be made there is a male faston terminal: one for phase L, one for neutral N and one for grounding PE. Just connect each of the 3 terminals with the respective cable, equipped with a faston terminal with female coupling.

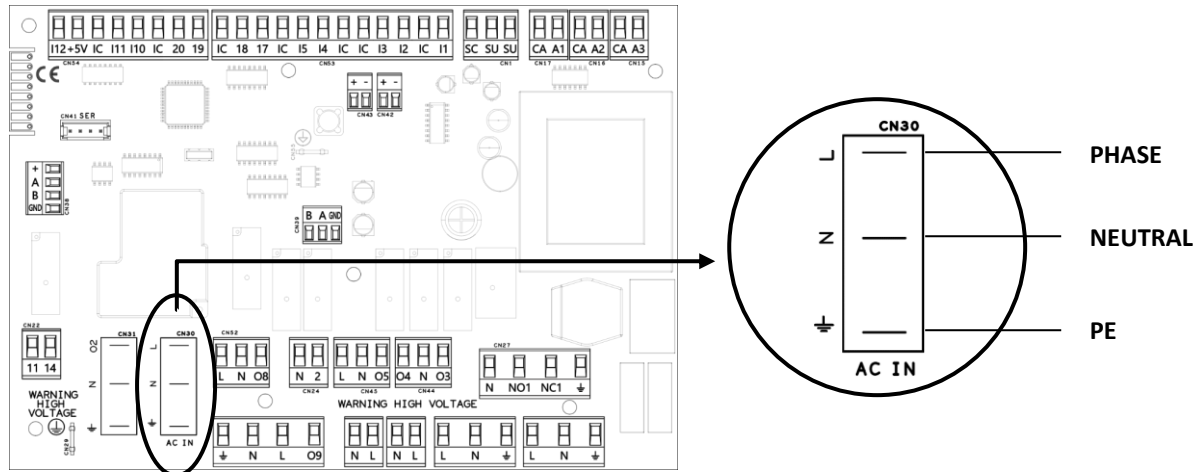

ONLY FOR UNIT SIZE 100 VERSION A or I

Bring the 230V power supply only to the terminal block in the electrical panel under the power board, connecting only to the terminals indicated in the picture.

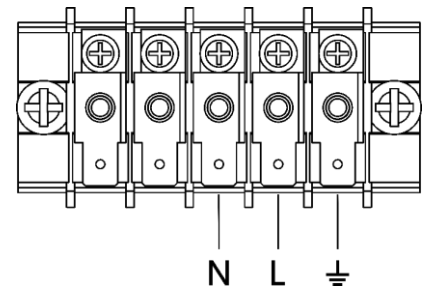

USER CONNECTIONS

Pay attention: Correct installation of the unit provides a direct electrical connection between the zone valve (or thermal head) at 230 V and the terminals N and 2. The zone valve must have a limit switch contact to activate the system pump. Electrical connections different from the one indicated, may not grant the correct water flow to the unit, and consequently lead to problems on the functioning

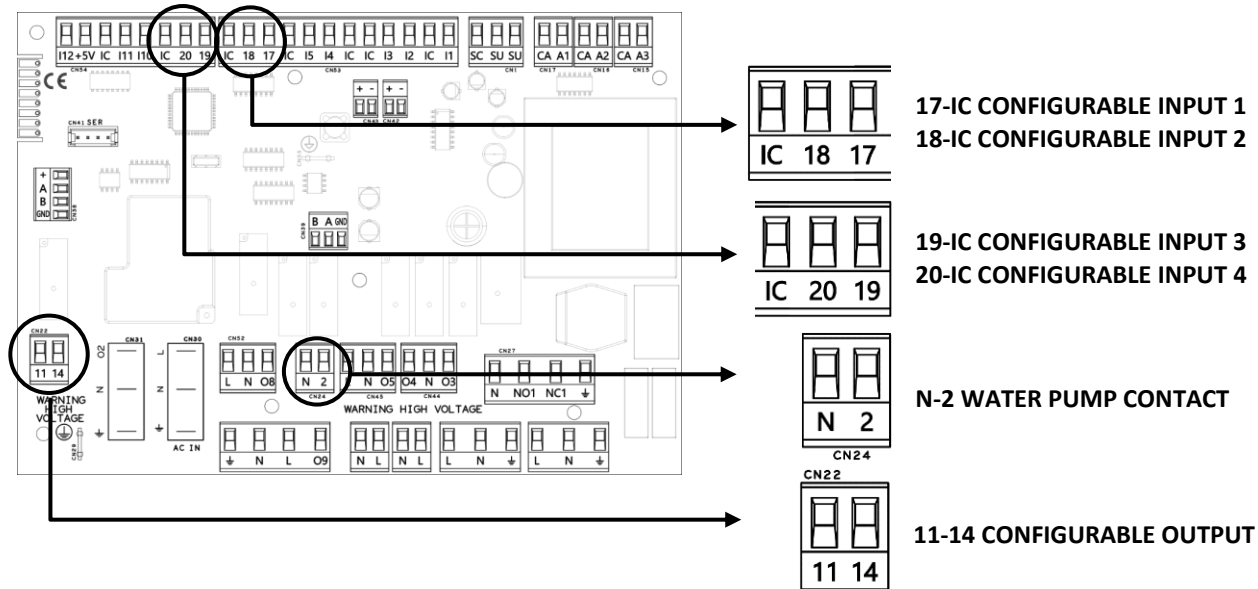

CONFIGURABLE CONTACTS

The terminals (17-IC) - (18-IC) - (19-IC) - (20-IC) are the configurable commands; there are 4 digital inputs that can be configured to perform various functions. ATTENTION: **connect only the dry contacts** and not the tension ones.

POSSIBLE CONFIGURATIONS	OPEN CONTACT	CLOSED CONTACT
Remote ON/OFF	Unit turned off at distance	Unit turned on and managed by the display
Summer/winter switching	Unit in summer mode	Unit in winter mode
Fresh air activation	with external dampers: renewal off without external dampers: renewal at minimum	Fresh air set from the display
Fresh air forcing	Fresh air set from the display	The fresh air is at max until the contact is closed
Air treatment enabling	Heating, cooling and dehumidification non-active	Heating, cooling and dehumidification active according to the set from the display and to ambient conditions
Boost mode	Fresh air set from the display	The fresh air is at max until the contact is closed and for the further 10 minutes
Temperature control	summer: air conditioning not active winter: heating not active	summer: active air conditioning winter: heating active
Humidity control	summer: dehumidification not active winter: dehumidification not active	summer: dehumidification active winter: dehumidification not active
Kitchen extractor hood cope	Standard unit functioning	The unit balances the air expulsion of the kitchen extractor, so the external flux towards the internal raises the max, while the internal flux towards the external is reduced to the min.
Ionizer	Ionizer off	Ionizer on
Fireproof  <i>This configuration is the only one that can be used even when the unit is managed by serial. In this case it works only if it is connected to terminals 17-IC (Configurable input 1)</i>	Unit switched off with priority over any other logic	Unit active and managed from the display, after resetting any previous fire alarm exclusively from the display, by pressing the ON / OFF button

For every single configurable control, it is possible to invert the functioning logic

All the settings which are not used from configurable controls, have to be done manually from the display



**AVVERTENZA
CAUTION**

In addition to the electrical wiring, the configurable controls must be set from the display during the initial start-up; Make reference to the dedicated paragraph.

EXAMPLES:

- **The user requests turning the unit off and on from a wall switch:** use the first configurable control, connect the 2 wires of the switch to the 17-IC terminals and upon the first start of the unit set the first command configurable as remote ON/OFF.
- **There is a control unit of the temperature control system with a dry contact for summer/winter switching and a dry contact to enable air treatment:** use the first configurable control as summer/winter switching and the second one as air treatment enabling, connect the first contact on terminals 17-IC and the second contact on terminals 18-IC and upon the first start-up set, both contacts with the relative functions.

The clamps **11-14** are a configurable output. We suggest to set the exit as general alarm or as dew-point alarm. The control is a dry contact. Follow the process indicated in the “installer parameters configuration” for this setting.

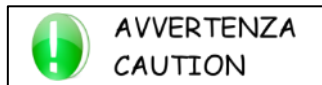

In addition to the electrical wiring, the configurable output must be set on the display during the first start-up; make reference to the dedicated paragraph.

Clamps N-2 must be connected to a zone valve, a water valve or a water pump (max 1 A) to control the water-supply to the unit. The control is in 230 V. For devices with consumption over 1 A, insert a power relay. **In versions “RER/REV - I”, if contacts N-2 are not corrected as indicated, the unit can be seriously damaged and, in this case, the warranty expires.**

CO₂ PROBE CONNECTION [OPTIONAL]

For the functioning and the supplying of the CO₂ probe you need to connect a 4-wires cable from the probe to the unit; for the connection, please follow the indications/procedure here below:

The terminals 1 and 2 of the probe must be connected to the terminals of the appropriate transformer for the 24V power supply of the probe, pay attention to respect the correct polarities that are indicated on the probe and on the transformer.

The terminal 5 of the probe must be connected to **terminal 15 of the power board**, extract the connector to be able to connect it.

The probe terminal 6 must be connected to any **terminal IC** of the control terminal board.

MODULATING VALVE 0 – 10 V CONNECTION [OPTIONAL]

For the functioning and the supplying of the valve you need a shielded cable with 2 wires from the valve to the unit; then, please connect it following the indications here below:

The valve signal terminal must be connected to **terminal A3 of the power board**.

The GND terminal of the valve signal must be connected to **the AC terminal of the power board**, pay attention not to disconnect the wires already connected.

The supplying to the valve should not be levied from the clamping box of the unit: please, use a dedicated power supply.

If the negative clamp of the valve supplying and the signal GND are in common, they have to be wired together.

9.5.2 Display

The display and the cable are inside the electrical panel, pay attention not to make them fall.

PLACING AND FIXING OF THE DISPLAY

The display should be installed in a practical position, so that the user can execute the fundamental operations, display the functioning status of the unit and, eventually, the alarms.

It should be placed far away from heating sources and air flows, otherwise temperature and humidity probes could read incorrect values and this will lead to a wrong functioning of the unit. For assembly proceed as follows:

- Plan a 503 box for the horizontal in-wall placement;
- Unscrew the lower screw of the display closing;
- Pass the cable to the dedicated back holes and fix the base on the on-wall box;
- Proceed with electrical wiring and close the control.

WIRING THE DISPLAY

The display always supplied with the machine is the primary display, the display supplied when the second display option is purchased is the secondary one. Both displays have full functionality and can work independently, what differentiates them is the address with which they are pre-programmed, all the primary displays have address 1 and the secondary ones 2. This address can be verified by entering the appropriate screen accessible from the password menu by entering '2020'. Normally it is sufficient to connect the primary display of each machine to the same machine with which it was sent. If the second display option is purchased, certain verification steps must be added: firstly, connect only the second display and check that the address is 2, then connect only the primary display and check that the address is 1. Checks can be performed without removing the electric power supply. If the addresses are both correct can be connected, otherwise check that the displays have not been mistaken with other machines. If not, change the display address to have one at address 1 and the other at 2. The displays can be connected indifferently to the two relevant terminals on the board as indicated in the image below or the second can be connected in parallel to the first starting from the terminal on the primary display. **Never connect two primary or secondary displays to the same unit which could irreparably compromise operation of the electronics.**

To connect the display, the cable from the unit must be connected as shown on the right:

- (negative) first wire and shield
- + (positive) second wire

For the connection, it is mandatory to use a shielded and twisted cable like the 2 metre one supplied, or like the 5, 10 or 20 metres cables supplied on request.

Alternatively, especially in the case of installations where there are possible electromagnetic interferences that may compromise communication between the board and the display, it is advisable to use a CEAM Y08761 cable or equivalent (2-wire shielded and twisted belden cable).



**ATTENZIONE
WARNING**

If the poles are inverted, the display will not function. The poles are indicated both on the serigraphy of the power board and on the back of the display.

The cable should be connected as shown here below:

POWER BOARD ON UNIT

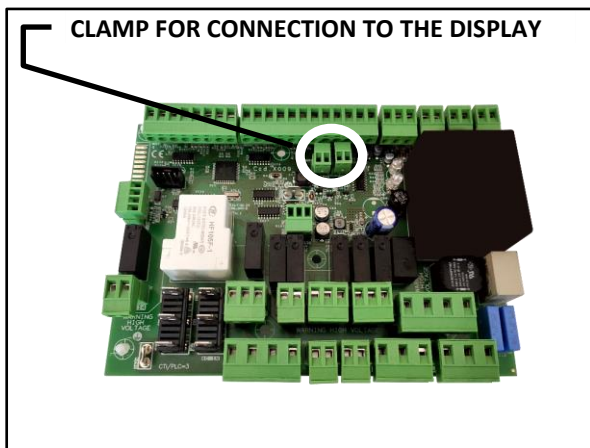

DISPLAY TO BE FIXED IN THE AMBIENT

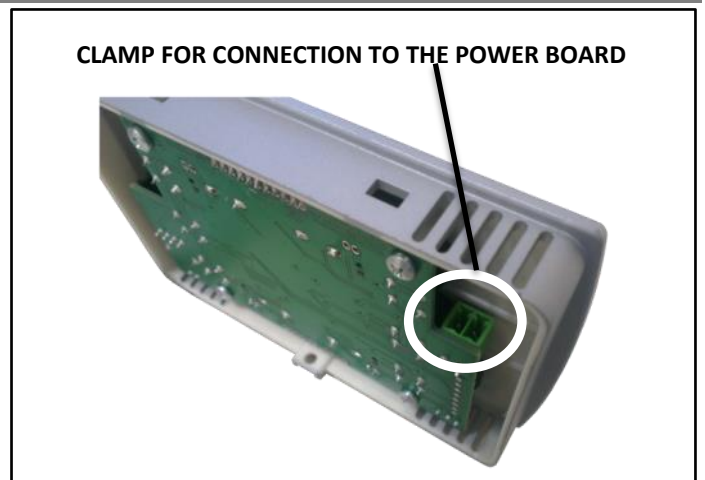

**ATTENZIONE
WARNING**

It is recommended to keep the communication cable between the board and the display as far as possible from any power cable, in order not to compromise the communication between the two. Therefore it is strictly **FORBIDDEN** to pass the cable with power cables.

9.5.3 RS485 - Modbus connection [optional]

SLAVE (primary)

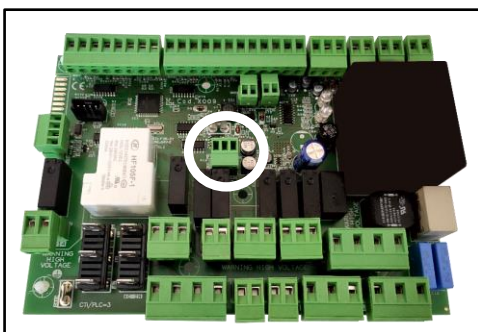

Unit slave by supervision

MASTER (secondary)



Unit master to specific devices

For the connection of all the Modbus system/network use a CEAM Y08761 cable or an equivalent one. Depending on use, connect the Modbus RS485 cable on the removable clamp indicated on the picture:

- + (positive pole) to clamp **A**
- - (negative pole) to clamp **B**
- the shielding braid to terminal **GND**

Respect, on all the connected devices, the connection A, B, GND.

For the Modbus parameters configuration, refer to the installer paragraph on the following pages.

RS485 Modbus connection is optional, but the clamp should be always present.

9.6 FIRST START, CALIBRATION AND CONFIGURATIONS



Initial start-up, calibration and configuration must be carried out exclusively by specialist personnel. DO NOT IMPROVISE, UNIT MALFUNCTION DANGER

Before starting, check that all the panels are in their position and tightened with their screws.

Follow these instructions carefully for commissioning:

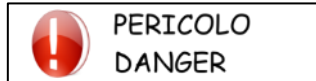

Check that all the hydraulic, electric and aeraulic connections are correctly installed and that all the indications given on the labels and user manual are observed.

Check that the refrigerant circuit taps, if present, are open and that the hydraulic plant is vented, by eliminating any residual air, charging it gradually and opening the vent devices on the top side.

Before using the unit, supply water and check that there are no water leaks.

All the operations are clearly explained in the following paragraphs.

9.6.1 Starting and calibration of unit air flow

Power the unit. After few seconds, the display will turn on and the unit will be ready to function, autonomously.



For the calibration, you need an anemometer for ducts (airflow hot wire measurer for duct use). In the following lines you will find where to measure to detect the airflow.

Now it is possible to proceed with the calibration.

The RER/REV are small air handling units which recirculate the ambient air and exchange it with the external one.

Every installation is different from the others, so it is fundamental to measure and correct the air flows, according to the real functioning conditions. In fact, the units are programmed to offer a "fixed" prevalence, but almost certainly it will not be exactly the one suitable for the installation. It is therefore essential to correct the air flow rates in the various operating conditions:

- Recirculation only (phase 1)
- Renewal only (phase 2)
- Recirculation + renewal (phase 3)

If the calibration will not be done or not correctly done, the unit RER/REV will have air flows, different from the project, and the heat recovery will lose efficiency.



The unit not-calibrated or incorrectly calibrated by specialized staff is to be considered excluded from the warranty.

The following images show where to measure the air flow.
Refer to this page during all the calibration process.

RER 015

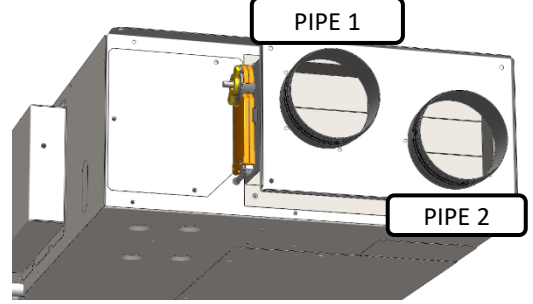
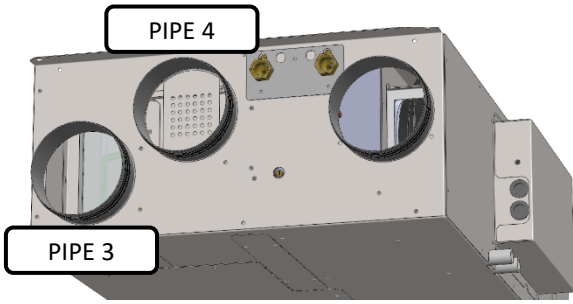

RER 020

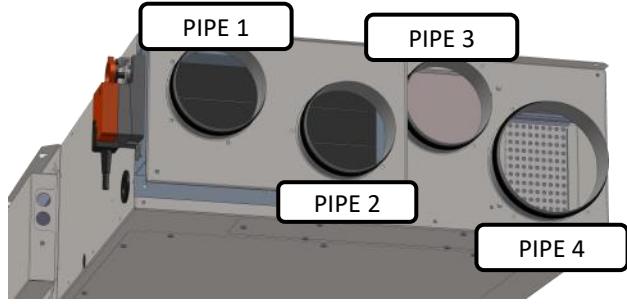

RER 035

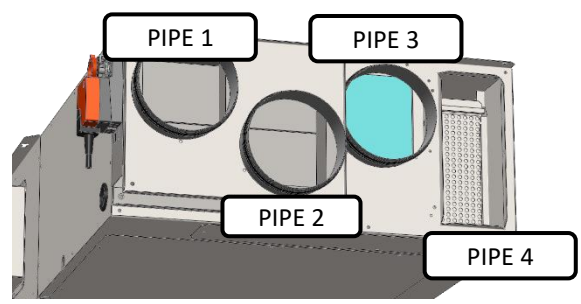

RER 050

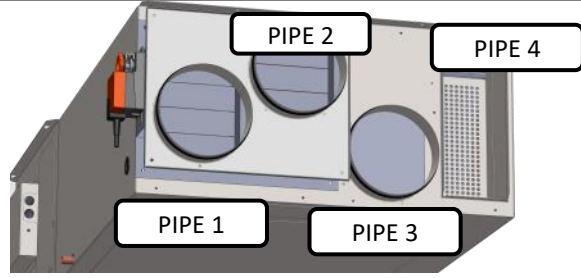

RER 100 ELECTRIC PANEL SIDE

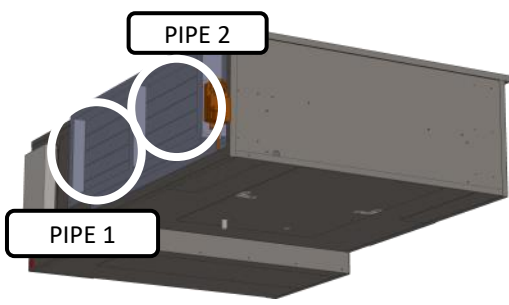

RER 100 OPPOSITE SIDE

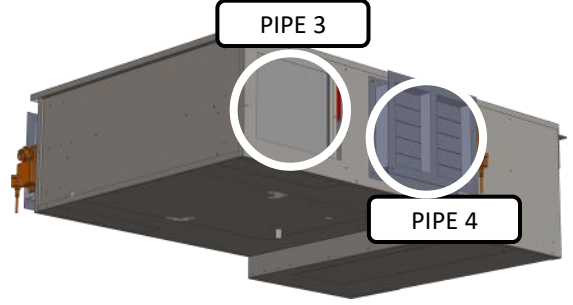

PIPE 1 – EXHAUST AIR EXPULSION FROM EXPULSION FAN

PIPE 2 – EXTERNAL AIR EXTRACTION BY SUPPLY FAN FOR RECOVERY

PIPE 3 – AMBIENT AIR EXTRACTION BY EXTRACTION FAN FOR EXPULSION (EXTRACTION FROM BATHROOMS AND KITCHEN)

PIPE 4 – AMBIENT AIR EXTRACTION FOR RECIRCULATION (EXTRACTION FROM BEDROOMS AND LIVING ROOM)

REV 020 and REV 035 TOP VIEW

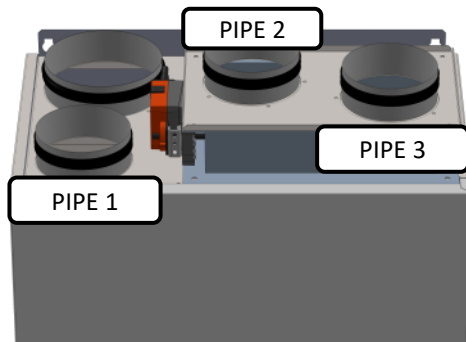

REV 020 and REV 035 LOWER VIEW



REV 050 TOP VIEW

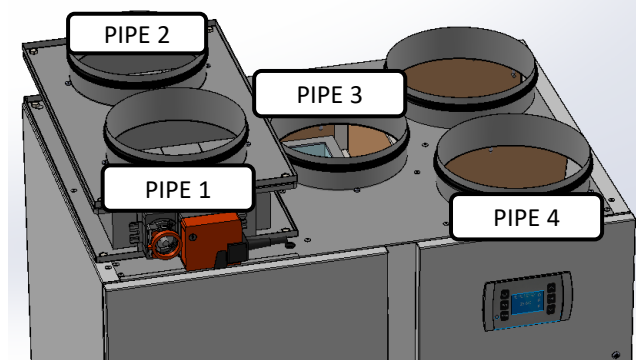

PIPE 1 – EXHAUST AIR EXPULSION FROM EXPULSION FAN

PIPE 2 – EXTERNAL AIR EXTRACTION BY SUPPLY FAN FOR RECOVERY

PIPE 3 – AMBIENT AIR EXTRACTION BY EXTRACTION FAN FOR EXPULSION (EXTRACTION FROM BATHROOMS AND KITCHEN)

PIPE 4 – AMBIENT AIR EXTRACTION FOR RECIRCULATION (EXTRACTION FROM BEDROOMS AND LIVING ROOM)

Usually the fan of an anemometer has a diameter of less than 20 millimetres. It will be necessary to make a hole on pipes 2, 3 and 4 to insert the anemometer. You will not need to do a hole on pipe 1.

For the calibration, you need to access to the dedicated menu. As anticipated, the calibration process is divided in 3 phases. During each phase, you are required to modify one (or more) parameters to reach the desired air flows' values.

During the calibration you will need to move several times from the on-wall display (for values modifications) to the ducts (for flows measures); if the display and the ducts are very far, we suggest disconnecting the display from the wall and connect it temporary to the unit; for this temporary connection you need a 2 m cable.

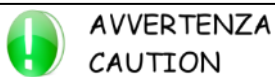

AVVERTENZA CAUTION

It may occur that in some installations there are too long or too tight channels: these will create large pressure drop leading to a large increase of the fans speed and consequently to uncomfortable noisy level. It is suggested, during the calibration, not to exceed a noise level acceptable by the user. A 10 – 15% reduction of the air flows is acceptable.



AVVERTENZA CAUTION

Read carefully all the following information before starting the calibration process. Then, start reading again and execute all the passages indicated.

STARTING CALIBRATION

CALIBRATION - PHASE 1

Place on the display; enter the main screen by pressing EXIT (more times, if necessary) or pressing ON/OFF if the unit is turned off.



If for 30 seconds, on the installer menu, no key is pressed the main screen is displayed. In this case, repeat the process from phase 1.

During modification phase (highlighted parameters), program will wait for the confirmation without exiting.



1. Press at the same time the keys on the right side UP, DOWN and OK.
2. The screen on the left will appear. This screen is requiring you the password.
3. Insert 0099 and press OK to confirm.



Now we are within the calibration menu, as shown in the picture on the left: in the upper part you see the phase of calibration you are at the moment while, under the line, you see the parameters you have to modify: in this case there is only one parameter to modify.

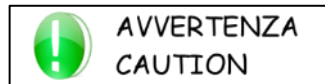

ATTENTION: if the unit does not have the external damper option, completely skip the next lines and continue the calibration from CALIBRATION PHASE 2

1. Press OK, and you will see a countdown, necessary to the unit to pass in the modification mode. Once the countdown is finished, the previous screen will be displayed again, but the parameter to modify will not be displayed any more.
2. Place the anemometer on pipe 4 (recirculation), refer to the dedicated previous page. The measured air flow rate shall be as shown in the table.
3. If the anemometer reads a different air flow, with UP and DOWN modify the speed of the fan until you find the desired air flow.

Model	Nominal air flow (m³/h)
015	160
020	260
035	380
050	520
100	1000

Write the set value on the table at the end of the paragraph.

By pressing EXIT, you confirm the value and come back to the calibration menu.

CALIBRATION PHASE 2

Press DOWN to move to the phase 2 of the calibration; in this phase we calibrate the unit in only recirculation mode.

To do this we will modify the speeds of the supply fan and of the extraction fan.

The screen you will display now is the one on the left, with 2 parameters (each one indicated the % of rotation of the dedicated fan).

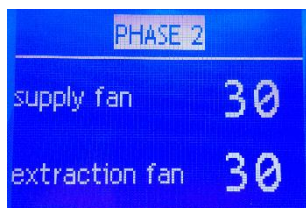

1. Press OK, and you will see a countdown, necessary to the unit to pass in the modification mode. At the end the previous screen will be displayed again and the parameter to modify will appear highlighted.
2. Insert the anemometer in pipe 2, The measured air flow rate shall be as shown in the table.
3. If the anemometer reads a different air flow, with UP and DOWN modify the speed of the fan until you find the desired air flow.

- Press OK to move to the second parameter, which is the extraction fan.
- Insert the anemometer in pipe 3, The measured air flow rate shall be as shown in the table.
- If the anemometer reads a different air flow, with UP and DOWN modify the speed of the fan until you find the desired air flow.

Model	Nominal air flow(m ³ /h)
015	80
020	130
035	190
050	260
100	500

Write the set value on the table at the end of the paragraph.

By pressing EXIT, you confirm the value and come back to the calibration menu.



**ATTENZIONE
WARNING**

Attention: during the calibration phase 2 it is extremely important that the air flow rates of pipe 2 and of pipe 3 are coincident, otherwise the air flows are not balanced. This leads to an incorrect functioning of the RER /REV unit and to a lower efficiency of the heat recovery.

CALIBRATION - PHASE 3

Press DOWN to move to the phase 3 of the calibration: in this phase you will calibrate the unit in recirculation + fresh air mode. To do this, you will have to modify the values of speeds for supply fan and the opening of the recirculation damper.

The screen you will display now is the one on the left, with 2 parameters (the higher one indicates the % of supply fan rotation, while the lower one indicates the % of opening for the recirculation damper).



- Press OK, and you will see a countdown, necessary to the unit to pass in the modification mode. Once the countdown is finished, the previous screen will be displayed again, but the first parameter to modify will be highlighted.
- Insert the anemometer in pipe 2, The measured air flow rate shall be as shown in the table.
- Insert the anemometer in pipe 4, The measured air flow rate shall be as shown in the table.
- If the anemometer indicates a different flow rate, pressing the UP and DOWN buttons change both values displayed in the display. To change the edit value, press the OK key.

Model	Nominal air flow (m ³ /h)
015	80
020	130
035	190
050	260
100	500

By increasing the % of the supply fan, you increase the sum of the flows of pipe 2 and 4, and vice versa. By increasing the % of the opening of the recirculation damper you reduce the flow on the pipe 2 and you increase it on pipe 4. By decreasing the % opening of the recirculation damper you increase the flow on the pipe 2 and reduce it on the pipe 4.



**AVVERTENZA
CAUTION**

ATTENTION: the damper moves slowly; once the opening has been modified, wait a few seconds for correct positioning.

At the end of calibration phase 3, it is essential to have obtained 2 identical values of air flow for both pipe 2 and opening 4. The correct air flow rates are shown in the table.

Model	Nominal air flow (m ³ /h)
015	80 + 80
020	130 + 130
035	190 + 190
050	260 + 260
100	500 + 500

Write the set value on the table at the end of the paragraph.

By pressing EXIT, you confirm the value and come back to the calibration menu; press for some times EXIT to come back to the main screen.

CALIBRATION DONE

If the calibration display has been moved during the calibration, now you need to replace it in its original place.

The unit has been calibrated and now it is ready to function.

If necessary, it is possible to modify some values, described here below, for the setting of configurable parameters, exits and other functions.

9.6.2 Calibration values and parameters table

	UPPER VALUE	LOWER VALUE
PHASE 1		
PHASE 2		
PHASE 3		



**ATTENZIONE
WARNING**

After having finished the calibration and the parameters configuration, it is compulsory to send this page (via fax or email) with the fulfilled table, to the manufacturer, in order to activate the warranty. Otherwise, the warranty will expire.

9.6.3 Installer parameters configuration

To access the installer menu, follow these steps:

- Place on the main screen (press EXIT if necessary)
- Keep pressed for 3 seconds UP, OK and DOWN
- Insert '0010' as password and press OK to confirm



**AVVERTENZA
CAUTION**

If for 30 seconds, on the installer menu, no key is pressed the main screen is displayed. In this case, repeat the process from phase 1.



**AVVERTENZA
CAUTION**

USE OF KEYS

- With UP and DOWN you slide from one screen to another (some screens do not always appear)
- With EXIT you exit and enter the main screen
- With OK you execute the function indicated on the screen

Some screens may be not always present



Choice of the language



Choice of the unit of measurement of the temperature
Default: Celsius

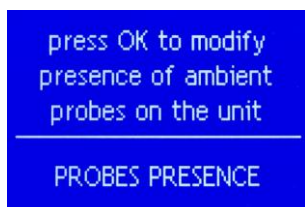

Possibility of setting the presence of ambient probes (temperature and humidity) inside the unit.
The ambient probes on the display are always present.

press OK to modify
presence of CO2 probe

NO PROBE

Possibility to set the presence of a CO₂ probe

press OK to modify
probes to use
for treatment

PROBES ON DISPLAY

Setting what probes are used to measure temperature and humidity:

- Probes on the display
- Probes on the unit

Default: probes on display

press OK to modify
automatic temperature
treatment option

DEFAULT VALUE

Setting the management of the treatment (dehumidification, cooling and heating) in automatic mode:

- pre-set values (cannot be modified)
- manual mode
- time bands

Default: pre-set values

press OK to modify
supply temperature
control

min winter: 18.0°C
max summer: 29.0°C

Possible configuration of the on/off control of supply temperature, when the values are not respected the unit activates the pump contact and starts water flows to dilute/dissolve.

Default: winter 8°C - summer 40°C

press OK to modify
the cooling
management

WATER + COMPRESSOR

Possibility to choose how to cool the air:

- compressor only: cooling performed by switching on the compressor
- water only: cooling performed by moving water through the coil
- water + compressor: cooling performed with water or with the compressor according to the ambient temperature distance from the set point

default: compressor only

press OK to modify
supply temperature
control

FROM SUPPLY PROBE

Possible configuration of the adjustable control for supply temperature: you can decide whether to do the regulation for the manual heating “from supply probe” or “from ambient probe”.

default: from supply probe



Possible configuration of the dew-point control (dew-point, condensation point)

This function allows to the unit to control precisely when inside the habitation, in summer, there is the risk of condensation on the radiant panels and of soaking the involved surface of the panels. You can set “Variable dew-point” with the correspondent differential or “Fixed dew-point” with the correspondent fixed value.

- “Variable dew-point”: water temperature is read and the differential is added: so, when the system and the unit receive colder water, the correct dew point is automatically re-calculated;
- “Fixed dew-point”: constant value, the unit will calculate the dew point always on that value.

When the dew-point is approached, the unit activates the dehumidification and stops renewal to avoid the introduction of humidity from outdoor and it increases recirculation.

To disable this function set “Fixed dew-point” and set as fixed value a very high temperature, i.e. 25 or 30 °C as default.

Default: fixed dew-point with fixed value 19.0°C.

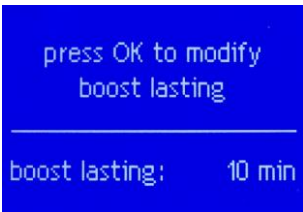

Setting of the duration of turbo mode, that is the duration of the activation of the maximum renewal.

Default: 10 minutes

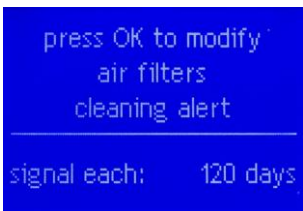

Possible modification of the signal for cleaning the filters.

A reminder will be indicated on the display (main screen): it is possible to choose from 3 months to 6 months for the reminder.

default: 120 days



Possible setting of the 4 configurable controls; these are 4 digital inputs which can be configured to execute several functions. For the electrical wiring and other information, make reference to the dedicated paragraph in the previous pages (see paragraph 5, page 52 and following).

Each control can be set as: remote on/off, summer/winter switching, renewal enabling, forced renewal, treatment enabling, boost mode activation, temperature request, humidity request, kitchen extractor hood activation.

For each control set it is possible to invert the logic.

It is not possible to set 2 configurable controls with the same information.

ATTENTION: the configurable controls modify the operation of the unit, do not improvise

default: all 4 commands not active and with logic inversion set to no

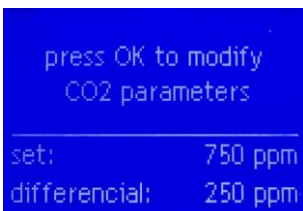

Possibility to set the parameters for regulation of renewal by CO₂ probe.

CO₂ probe and unit set in automatic mode, renewal is automatically manages, as in the following:

- up to 500 ppm renewal will be 1
- among 500 – 1000 ppm renewal will be from 2 to 4
- over 1000 ppm renewal will be 5

Default: 750 ppm set and 250 ppm differential

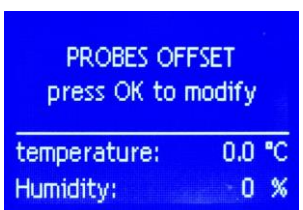

Possibility to modify the reading of the temperature and humidity probes.

Default: 0.0 °C and 0%



Possibility to set the configurable output.

The exit could be inactive, set as 'general alarm' or as 'dew-point alarm'.

For each control set it is possible to invert the logic.

For the electrical wiring and other information, make reference to the dedicated paragraph in the previous pages.

Default: output not active

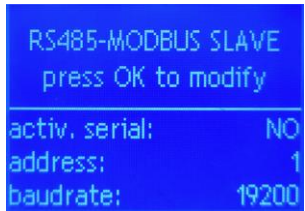

Possible setting of parameters for Modbus communication on RS485 serial port (primary).

The screen is always present. The possible configuration are as follows:

- OFF: serial not enabled
- SLAVE: the unit is controlled by serial
- SL-SEASON: possibility to set only season by serial, while the unit is managed by display

More information available on request.

Default: serial not enable, address 1 and baud rate 9600

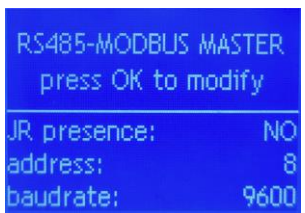

Presence setting of remote JR device on secondary RS485 serial port (secondary).

The unit will be the master towards the device.

Address and baud rate are fixed values that cannot be changed.

For the connection to the serial port, see the paragraph "Electrical connections".

For the configuration of the JR device, refer to the respective installation manual.

default: JR not present

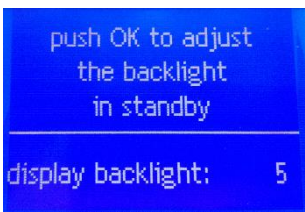

Possibility to modify the backlight when the display is in standby mode.

Default: 5

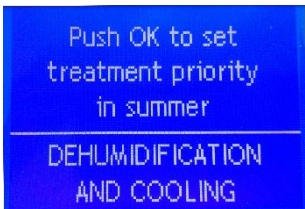

You can decide if, in summer, you want to start with the air treatment for dehumidification and cooling, only dehumidification or only cooling.

Default: dehumidification and cooling



Possibility of displaying the alarm history of the unit.

In the alarm history are kept in memory all the alarms, with the indication of the number of alarms and their date (day, month and year).

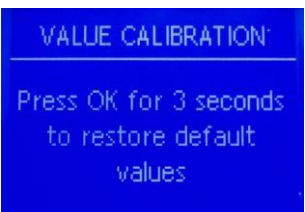

Possibility of restoring the default values of the calibration.

If, during the calibration, the values modification is wrong, or if you change the ducts or other parts of the system, it may be useful to restore the calibration values and start it again.

CONSTRUCTOR VALUE

Press OK for 3 seconds
to restore default
values

Possibility of restoring all the installer and user parameters.

If you wrongly modify some parameters on installer or on user menu, you can restore the default values.

ATTENTION! resetting all user settings are deleted, such as the desired temperature and humidity, the set season and all the installer parameters, but the calibration parameters and time zone programming are not deleted.

HiDew

Dehumidifiers 

HiDew S.r.l.
info@hidew.it - www.hidew.it

Operational headquarters: Via dell'Artigianato, 5 – 35026 – Conselve (PD) – Italy
Tel +39 049 9502511

Registered office: Viale Spagna, 31/33 - 35020 - Tribano (PD) - Italy
Tel +39 049 9588511 - Fax +39 049 9588522

EEE Register: IT18080000010604